



AL 400

Operating instructions

**Before transporting and using the machine,
please read the instructions thoroughly!**

Service and information

Your BOMAR dealer:

Direct BOMAR contact:

BOMAR spol. s r.o.
Těžební 1236/1
62700 Brno
Czech Republic, EU

telefon: +420 – 533 426 100
fax: +420 – 533 426 109
e-mail: info@bomar.cz
www: <http://www.bomar.cz>

We are available:

Mondays to Fridays

7⁰⁰ – 16⁰⁰

Version:

1.16 / Jan. 2020
rev. 1

BOMAR, spol. s r.o. © – Subject to modifications and amendments.

EC Declaration of Conformity

1) 2) We:

BOMAR, spol. s r.o.

Těžební 1236/1

627 00 Brno, Czech Republic

Id. No: 48908827

declare herewith

that the following designated device based on its conception and construction as well as the design launched by us meets the relevant basic safety requirements of the decrees of the government.

This statement applies exclusively to the machine device in conditions in which it was brought to the market. It does not apply to parts subsequently added by the end user or to modifications performed subsequently by the end user.

In the event of any device modification not approved by us this declaration shall lose its validity

Name: **Circular Saw**

Type : **AL 400 Semi-automat**

Serial number:

Manufacturer **BOMAR, spol. s r.o., Těžební 1236/1, 627 00 Brno**

Product data

Determination: for cross dividing and cutting of rolled and towed bars and profiles made of aluminium, copper and its alloys with angle cut from -60°(L60°) to +90°(R90°)

Description: Stand, table, cutting unit with the saw blade and drive, microniser, Pneumatic-hydraulic unit, el. switch board safety covers,

Pneumatic NO YES Hydraulic NO YES Control system NO YES

Technical data:

Blade speed	50m.s-1
Cutting angle	-60°+90°
Total dimensions in mm (lxwxh)	1000x2200x1450
Supply voltage	3x400V+PE, or 3x 230V+PE
Total power requirement	3,8 kW
Weight	190 kg

Documentation:

Technical documentation for this machine device was elaborated in compliance with Government regulation no. 176/2008, Annex 7, part A.

The device meets relevant requirements of the given directives:

2006/42/EC

2004/108/EC

The applied harmonized standards, National standards and technical specifications:

ČSN EN ISO 12100:2011	ČSN EN ISO 16093:2018	ČSN EN ISO 13857:2008
ČSN EN ISO 4413:2011	ČSN EN ISO 4414:2011	ČSN EN 60204 -1 ed.3:2019
ČSN EN 55011 ed.4+A1:2017	ČSN EN 61000-6-2 ed.3:2006	ČSN EN 61000-6-4 ed.2+A1:2011

The product is safe on condition of the common and determined usage.

The conformity judging was performed according to §12, par. 3, let. a), of the Law no. 22/1997 Coll. as amended.

The declaration of conformity was carried out in the cooperation with the ³⁾ TÜV SÜD Czech s.r.o, Novodvorská 994, 142 21 Prague 4 – Czech Republic, Identification number: 63987121 - Inspection body no. 4002.

The inspection certificate no **08.416.885**

was issued

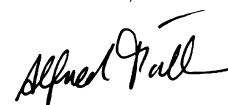

Brno, 28.1.2020

BOMAR, spol. s r.o.
Těžební 1236/1, 627 00 Brno
Czech Republic
IČO: 48908827
DIČ: CZ48908827

Alfred Pichmann, Managing Director

Point of issue, datum

Name and function of the responsible subject,
signature

1) Name, address and identification number of the subject issuing the conformity declaration (producer of importer)

2) Person authorized to complete the technical documentation

3) The authorized or accredited body co-operating on the conformity judging

!

If the equipment is installed without safety equipment offered by BOMAR, spol. s ro or its agents and used by the customer (or buyer) then EC declaration loses validity.
EC Declaration of conformity is valid only if customer (buyer) installed the BOMAR safety equipment with the machine or with some other with equivalent safety device in accordance with current applicable regulations and standards.
All machine elements and components that were built into the device by BOMAR, spol. s ro have been declared "identical" to a safety device, as offered by BOMAR, spol. s ro or its agents.

Content

1. SAFETY NOTES.....	7
1.1. Machine determination.....	9
1.2. Protective suit and personal safety.....	9
1.3. Safety notes for machine operator.....	10
1.4. Safety notes for the servicing and repairs.....	11
1.5. Safety machine accessories.....	11
1.5.1. Emergency Stop Switch.....	11
1.5.2. Workplace cover.....	12
1.5.3. Pedestal door.....	12
1.6. Umístění štítku stroje / Maschinenschild position / Position of machine label.....	12
1.7. Umístění bezpečnostních značek / Verteilung der Sicherheitszeichen / Position of safety symbols.....	13
2. MACHINE DOCUMENTATION.....	15
2.1. Technická data / Technische Daten / Technical data.....	16
2.2. Řezné rozsahy / Schnittbereiche / Cutting sizes.....	17
2.3. Rozměrové schéma / Aufstellzeichnung / Installation diagram.....	18
2.4. Popis / Beschreibung / Description.....	19
2.5. Transportation and stocking.....	20
2.5.1. Conditions for transportation and stocking.....	20
2.5.2. Transport and stocking preparations.....	20
2.5.3. Transport and stocking.....	20
2.5.4. Transportní schéma / Transport scheme / Transport scheme.....	21
2.6. Activation.....	22
2.6.1. Machine working conditions.....	22
2.7. Band saw unpacking and assembling.....	22
2.7.1. Machine installing and levelling.....	22
2.7.2. Machine disposal after lifetime.....	22
2.7.3. Kotevní plan / Verankerungsplan / Grounding plan.....	23
2.8. Electrical connection.....	24
2.8.1. Check the running direction of the cutting wheel.....	24
2.9. Connecting to the compressed air supply.....	24
2.10. Filling of the cooling system.....	25
2.11. Check machine function.....	25
2.12. Saw blade.....	25
2.12.1. Saw blade size.....	25
2.12.2. Selection of the saw disk.....	25
3. MACHINE CONTROL	27
3.1. Starting the saw.....	29
3.2. Control panel.....	29
3.3. Machine contro.....	30
3.3.1. Semi-automatic operation.....	30
3.3.2. Signal light.....	31
3.3.3. Cycle breaking.....	31
3.4. Circular saw adjusting.....	31
3.4.1. Set of clamping cylinders.....	31
3.4.2. Jaw console setting.....	32
3.4.3. Angular cut setting.....	32
3.4.4. Clamping adjusting.....	33
3.4.5. Speed adjusting of the arm lowering.....	33
3.5. Suction device (optional accessory).....	34
3.6. Material insertion.....	35
3.6.1. Handling agent selection.....	35
3.6.2. Insertion.....	35
4. MACHINE MAINTENANCE	37
4.1. Saw disk dismantling.....	39
4.2. Saw disk installation.....	39
4.3. Cooling agents and chips disposal.....	40
4.3.1. Cooling liquid inspection.....	40
4.3.2. Chips disposal.....	40
4.4. Hydraulic, Greases and oils.....	40
4.4.1. Lubricant greases.....	40
4.4.2. Lubrication.....	41
4.4.3. Hydraulic oils.....	41
4.4.4. Hydraulic oil level check.....	42
4.5. Pressure system servicing.....	42
4.6. Machine cleaning.....	42
4.7. Worn pieces replacement.....	43
4.7.1. Belt replacement.....	43
5. SCHEMATICS	45

5.1. Elektrické schéma /Elektroschema /Wiring diagrams – s frekv. měničem / mit Frequenzumrichter / without frequency convertor 3x400 V+PE,50Hz.....	47
5.2. Elektrické schéma /Elektroschema /Wiring diagrams s frekv. měničem / mit Frequenzumrichter / without frequency convertor 3x230 V+PE,50Hz.....	62
5.3. Elektroschema /Elektroschema /Wiring diagrams bez frekv. měniče / ohne Frequenzumrichter / without Frequency convertor, 3x400 V+PE,50Hz.....	77
5.4. Elektrické schéma /Elektroschema /Wiring diagrams – bez frekv. měnič e/ / ohne Frequenzumrichter /without Frequency convertor – 3x230 V+PE,50Hz.....	92
5.5. Pneumaticko-hydraulické schéma / Pneumatik-Hydraulikschemata / Pneumatic-Hydraulic diagram.....	108

6. VÝKRESY SESTAV PRO OBJEDNÁNÍ NÁHRADNÍCH DÍLŮ / ZEICHNUNGEN FÜR BESTELLUNG DER ERSATZTEILE / DRAWING ASSEMBLIES FOR SPARE PARTS ORDER..... 111

6.1. ALU 400 SEMI.....	112
6.2. Kusovník / Piece list / Stückliste - ALU 400 SEMI.....	113
6.3. ALU 400 SEMI.....	114
6.4. Kusovník / Piece list / Stückliste - ALU 400 SEMI.....	115
6.5. Podstavec / Base / Untersatz.....	116
6.6. Kusovník / Piece list / Stückliste - Podstavec / Base / Untersatz.....	117
6.7. Vana / Tank / Wanne.....	118
6.8. Kusovník / Piece list / Stückliste - Vana / Tank / Wanne.....	119
6.9. Válec / Roller / Zylinder.....	120
6.10. Kusovník / Piece list / Stückliste - Válec / Roller / Zylinder.....	121
6.11. Rozvaděč / Distributor / Verteiler.....	122
6.12. Kusovník / Piece list / Stückliste - Rozvaděč / Distributor / Verteiler.....	123
6.13. Kryt / Cover / Abdeckung.....	124
6.14. Kusovník / Piece list / Stückliste - Kryt / Cover / Abdeckung.....	125
6.15. Rameno / Shoulder / Sägerahmen.....	126
6.16. Kusovník / Piece list / Stückliste - Rameno / Shoulder / Sägerahmen.....	127
6.17. Rameno / Shoulder / Sägerahmen.....	128
6.18. Kusovník / Piece list / Stückliste - Rameno / Shoulder / Sägerahmen.....	129
6.19. Konzola / Console / Konsole.....	130
6.20. Stůl / Table / Tisch.....	132
6.21. Kusovník / Piece list / Stückliste - Stůl / Table / Tisch.....	133
6.22. Stůl / Table / Tisch.....	134
6.23. Kusovník / Piece list / Stückliste - Stůl / Table / Tisch.....	135
6.24. Válec upínací / Fixing cylinder / Spannzylinder.....	136
6.25. Kusovník / Piece list / Stückliste - Válec upínací / Fixing cylinder / Spannzylinder.....	137
6.26. Válec zvedací / Lifting cylinder / Hebezyylinder.....	138
6.27. Kusovník / Piece list / Stückliste - Válec zvedací / Lifting cylinder / Hebezyylinder.....	139
6.28. Upínání horní / Top clam / Spannvorrichtung oben.....	140
6.29. Kusovník / Piece list / Stückliste - Upínání horní / Top clam / Spannvorrichtung oben.....	141
6.30. Válec upínací / Fyxing cylinder / Spannzylinder.....	142
6.31. Kusovník / Piece list / Stückliste - Válec upínací / Fyxing cylinder / Spannzylinder.....	143
6.32. Klíče / Key / Schlüssel.....	144
6.33. Kusovník / Piece list / Stückliste - Klíče / Key / Schlüssel.....	145
6.34. Pneumatika / Pneumatics / Pneumatik.....	146
6.35. Kusovník / Piece list / Stückliste - Pneumatika / Pneumatics / Pneumatik.....	147

7. VÝKRESY SESTAV PRO OBJEDNÁNÍ NÁHRADNÍCH DÍLŮ – VOLITELNÉ PŘÍSLUŠENSTVÍ/ ZEICHNUNGEN FÜR BESTELLUNG DER ERSATZTEILE – OPTIONALE ZUBEHÖR/ DRAWING ASSEMBLIES FOR SPARE PARTS ORDER – OPTIONAL ACCESSORIES 148

7.1. Odměřován/ Measuring/ Gehrungsmessung (optional).....	149
7.2. Kryty / Covers / Abdeckungen.....	151
7.3. Kusovník / Piece list / Stückliste - Kryty / Covers / Abdeckungen.....	152

1. **Safety notes**

The operating instructions must be read by the person, who keeps in touch with the machine before transportation, installation, using, servicing, repair, stocking or removal!

The operating instructions include relevant information. The operator must familiarise himself with the install and operation, safety notes and machine servicing, because reliability and service life must be reached. The operating instructions must avoid risks, which are linked to work on the machine. Before transporting and using of the machine, please read the instructions thoroughly!

Attention!

*The operating instructions must be available at the machine!
Keep the operating instructions in good condition!*

1.1. Machine determination

The band saw **AL 400** is determined for cross dividing and cutting of bars and profiles made of aluminum, copper and its alloys with angle cut from -60° (L60°) to $+90^{\circ}$ (R90°)

Combustible materials are excepted for cutting! Any other usage and operation outside this range are unauthorized and the manufacturer/supplier does not accept any responsibility for any damages resulting from such misuse. **The operator has full responsibility!**

The machine is equipped with safety and protective guarding for operator and machine protection. Nevertheless, this safety and protective guarding cannot prevent injury. Service personnel must read this chapter and comprehend it, before he starts to work on the machine. **Always keep instructions about work safety!** Service personnel must take into account other aspects of the risk, which refer to the ambient conditions and the material.

Attention!

Consider the safety signs on the machine. Do not remove or damage them!

1.2. Protective suit and personal safety

Wear tight fitting overalls! Loose fitting clothes may be caught with machine parts and cause serious injury.

Wear protective gloves! Material cuts and saw band have sharp edges and may cause serious injuries.

Attention!

*Gloves you can use only at working material replacement (saw band)! The machine and accessories must be inactive!
If the machine is running, you must not wear gloves! It is dangerous, because some parts of the machine can catch gloves!*

Wear protective shoes with non-skid soles! The unsuitable shoes may cause balance loss and following injury. Falling work pieces may cause serious injuries too.

Wear protective goggles! Chips and cooling liquid may damage your eyes.

Always wear ear protections! Most of the machines emit up to 80 dB and may damage your hearing.

Do not wear jewellery and always tie back long hair! Moving machine parts can catch jewellery or loose hair and may cause serious injuries.

Operate the machine only when you are fit enough to work. Illnesses or injuries diminish concentration. Avoid machine work, which may compromise the safety of you and your colleagues!

1.3. Safety notes for machine operator

Attention!

*Machine can be operated by person older than 18 years!
Machine can be operated only person physically and mentally fit
for this activity*

Keep instructions and orders about work safety!

*Read the operating instructions, before you start to work on the
machine! Keep the operating instructions in good condition!*

Machine can be operated only by one person. Machine operator is responsible for presence of other persons by the machine.

Close covers before the machine starting and check, if the covers are not damaged. Damaged covers must be repaired or changed. Do not start the machine, if the cover is removed! Check, if the electric cables are not damaged.

- Do not hold the material for clamping to the vice and for cutting!
- Do not operate with the buttons and the switches on the control panel, when you have gloves!

Attention!

*Do not connect the machine to electricity if the covers are
removed. Do not touch the electrical equipment.*

- For machine starting take care, that there is nobody in the working area of the machine (it means in the working area of the vice, the saw band, the saw arm etc.).
- In no circumstances touch the rotating elements.
- Work on the machine only when the machine is in good condition!
- Check at least once in a shift, if the machine is not damaged. If the machine is damaged, you must bring the machine in order and you must inform your superior!
- Keep your working area clean! Ensure sufficient lighting in the working area.

WARNING!

*After switching off the machine, the blade will still rotate for at
least one minute. **Opening the door in this time is not allowed
and can cause serious injuries!***

- Take off the spilt water or the oil from the floor and dry it. Do not touch the cooling liquid with bare hands! Do not set the nozzle of the cooling liquid, when the machine is started on
- Do not remove the chips from the working area of the machine, when the machine is started on!
- Do not use the compressed air for the machine cleaning or for the chips removing!
- Use the protective instruments for chips removal!

Attention!

*Only a qualified professional can carry out the servicing and
repairs of the electric equipment! Take special care during the
work with electrical equipment. High voltage shock can have
fatal consequences! Always keep notes about work safety!
Otherwise, there is possibility of heavy injury!*

1.4. Safety notes for the servicing and repairs

Switch off the main switch and lock it, before you start service work! Otherwise, there is possibility of hazardous machine starting.

Only qualified person can do the servicing and repairs. For parts changing, use only parts, which are identical with the originals. Otherwise, there is possibility of health hazard. Use only recommended type of the hydraulic oils and oils and lubricants!

Do not remove or do not lock the limit switches or safety equipments! Any use of the saw, accessories or machine parts other than that intended by the BOMAR, spol. s r.o. company is not permitted. The guarantee on this product will be afterward lost and BOMAR, spol. s r.o. takes no responsibility for caused damages.

Attention!

Only a qualified professional can carry out the servicing and repairs of the electric equipment! Take special care during the work with electrical equipment. High voltage shock can have fatal consequences! Always keep notes about work safety! Otherwise, there is possibility of heavy injury!

1.5. Safety machine accessories

The machine is equipped with safety accessories. It protects the operator from injuries and the machine before damage. The safety accessories are blocking accessories, emergency switches and covers. Check once in a week the function of the safety accessories. If the safety accessories are functionless, you must stop work and repair or change the safety accessories.

Enhanced risk!

Do not come into or intervene in the cutting area. Otherwise, there is possibility of heavy injury.

1.5.1. Emergency Stop Switch

Emergency Stop Switch is used for emergency switching – off the machine in case defect or health hazard. By pressing **Emergency Stop Switch** will immediately stop all dangerous machine movements.

If any damages or fault appears, immediately press Emergency Stop Switch!

It is possible to release the pressed button by twisting of the upper part of the button.

The **Emergency Stop Switch** is placed at the control panel of the machine.



1.5.2. Workplace cover

The cover is locked during operation. **Do not dismount safety cover.**



The band saw is stated to the operation, when the covers is closed!

1.5.3. Pedestal door

WARNING!

*After switching off the machine, the blade will still rotate for at least one minute. **Opening the door in this time is not allowed and can cause serious injuries!***

Doors are secured with a lock. After cutting, machine is unlocked after about 50 sec.



The saw is stated to the operation, when the cover is closed!

1.6. Umístění štítku stroje / Maschinenschild position / Position of machine label



Machine label is located at the rear of saw pedestal.

1.7. Umístění bezpečnostních značek /
Verteilung der Sicherheitszeichen /
Position of safety symbols

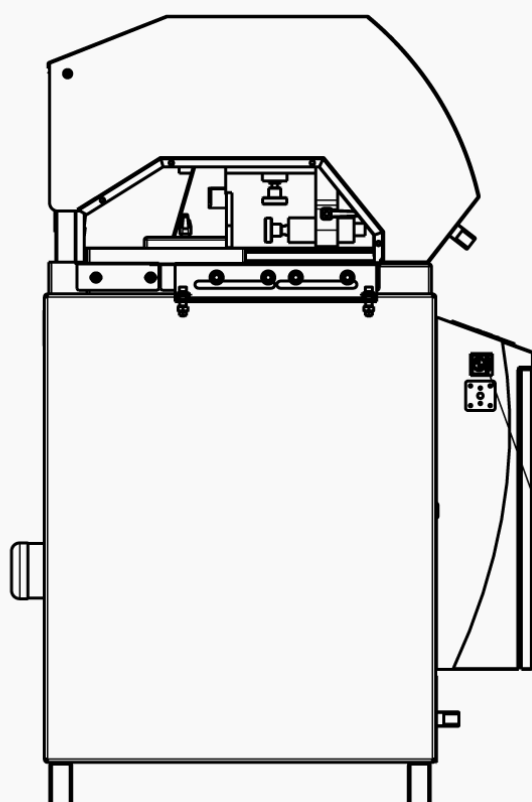
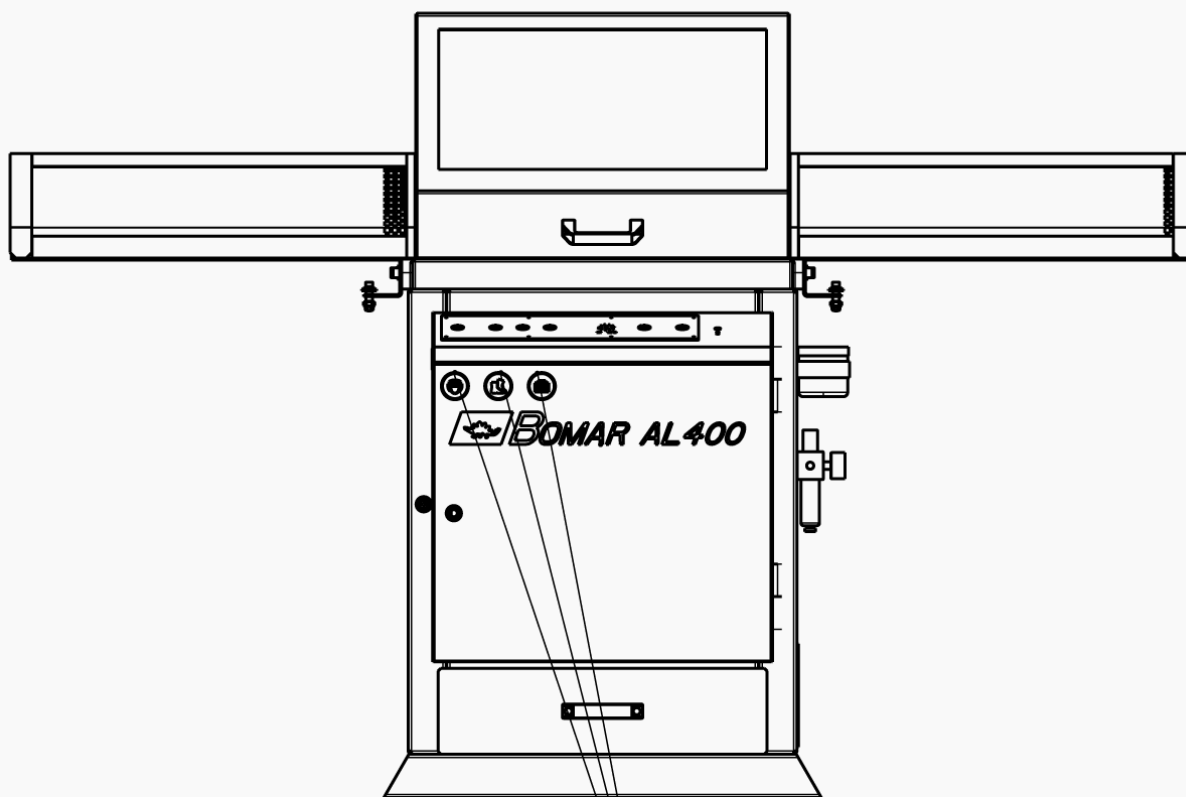

PO:
Noste pevnou pracovní obuv
Tragen Sie Sicherheitsschuhe
Wear fixed protective shoes

CZ:
Přečíst návod k použití
Bedienungsanleitung lesen
Read the operating instructions

OBS:
Noste ochranné brýle a sluchátka
Tragen Sie eine Schutzbrille und
Gehörschutz
Wear protective goggles
and headphones





HV
Hlavní vypínač
Hauptschalter
Main switch

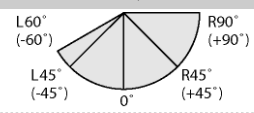

Bezpečnostní pokyny
 Sicherheitshinweise
 Safety notes

2. **Machine documentation**

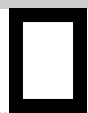
2.1. Technická data / Technische Daten / Technical data

Hmotnost stroje / Maschinengewicht / Machine weight:				
• Hmotnost / Gewicht / Weight	190 kg			
Rozměry stroje / Maschinengröße / Machine size :				
• Délka / Länge / Length	1000 mm			
• Šířka / Breite / Width	2200 mm			
• Výška / Höhe / Height	1450 mm / 1850 mm			
Elektrické vybavení / Elektrische Ausrüstung / Electrical equipment:				
• Napájení / Versorgungsspannung / Supply voltage	~3 x 400 V (230 V), 50Hz, TN-C-S/TN-C (dep. on saw ver.)			
• Příkon / Gesamtschlusswert / Total Input	3,8 kW			
• Max.jištění / Max. Vorschaltssicherung / Max. Fuse	16 A			
• Krytí / Schutzart / Protection	IP 54			
Akustický tlak / Schalldruckpegel / Acoustic pressure:				
• AL 400	$L_{Aeqv}=76,3$ dB			
Pohon / Antrieb / Drive:				
• Typ / Typ / Type	1LA 7166 – 2AA10			
• Výkon / Leistung / Output	3,0 kW			
Pneum-Hydraulické zařízení / Pneumatik-Hydraulikeinrichtung / Pneum-Hydraulic equipment:				
• Typ / Typ / Type	k115-100			
Rozměr pásu / Sägebandedimension / Band size:				
Ø400 × Ø30 × 3,6 mm				
Řezná rychlost / Schnittgeschwindigkeit / Cutting speed:				
50 m/s				
Řezné rozsahy / Schnittbereiche / Cutting size:				
				
L60° (-60°)	Ø96 mm	100×55 mm	45×125 mm	85×85 mm
0° (jaws in front)	Ø120 mm	220×25 mm	90×125 mm	110×110 mm
0° (jaws back)	Ø90 mm	285×70 mm	285×70 mm	70×70 mm
R45° (+45°)	Ø120 mm	150×40 mm	65×125 mm	100×100 mm
R60° (+60°)	Ø96 mm	100×55 mm	45×125 mm	85×85 mm
Level of acoustic pressure:				
Equivalent level of acoustic pressure A (noise) at operator position are $L_{Aeqv}=76,3$ dB. Mentioned values are levels of emission which doesn't have to represent safe levels. Factors which influence real level of acoustic pressure on machine operator are: working place characteristics, cut material, saw band. These factors have significantly influence on acoustic pressure.				

2.2. Řezné rozsahy /
Schnittbereiche /
Cutting sizes

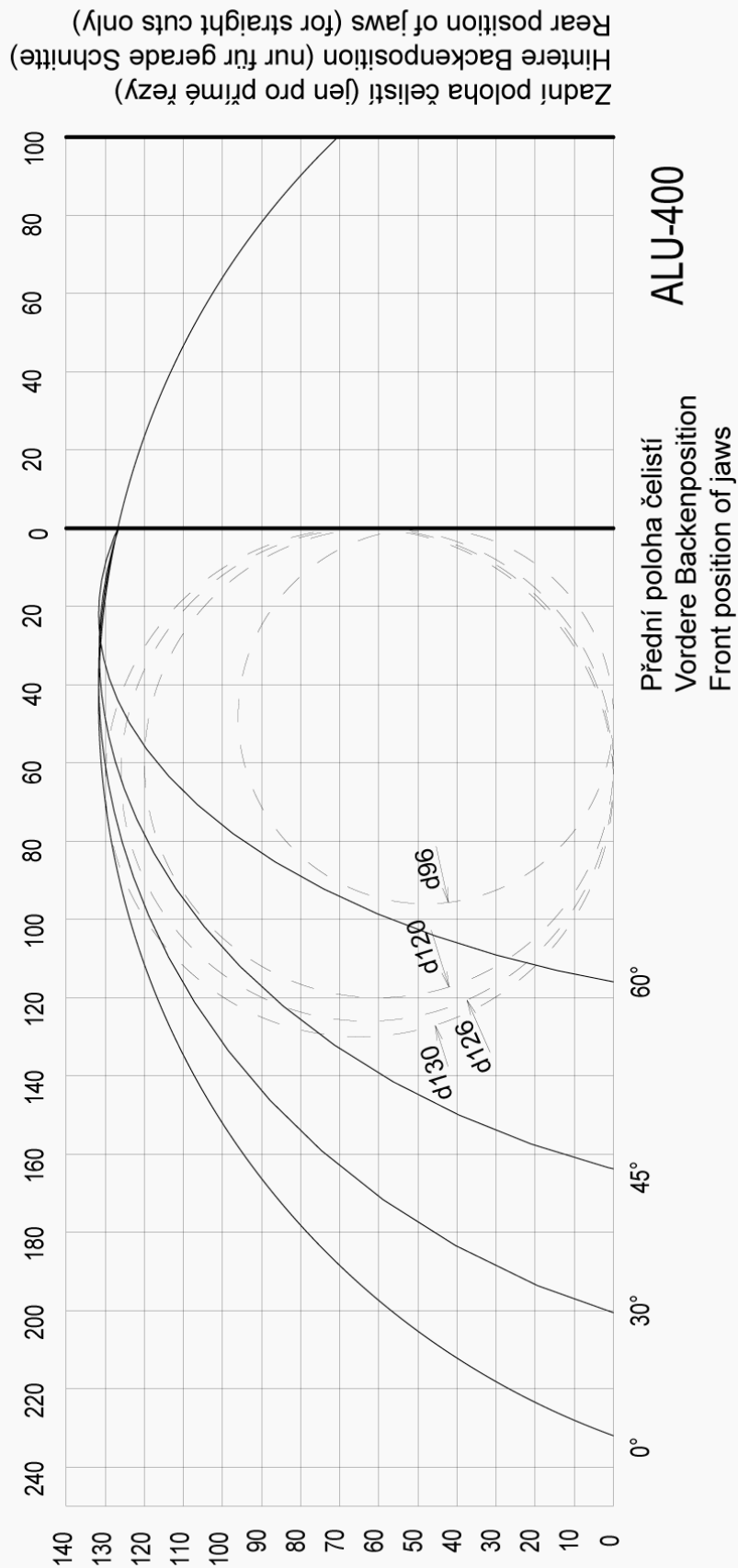

2.3. Rozměrové schéma /
Aufstellzeichnung /
Installation diagram

Dokumentace stroje
Dokumentation der Maschinen
Machine documentation

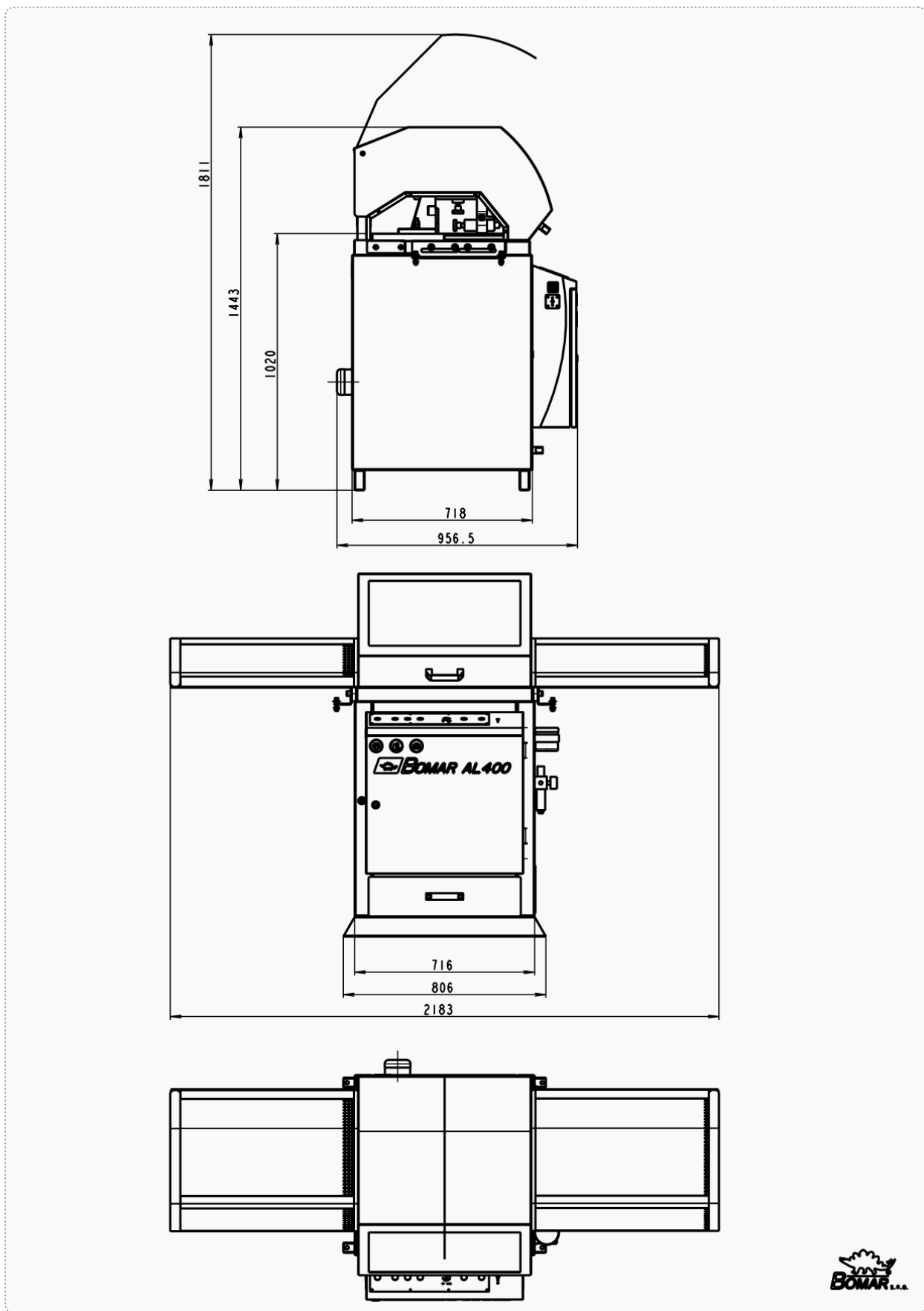

2.4. Popis / Beschreibung / Description

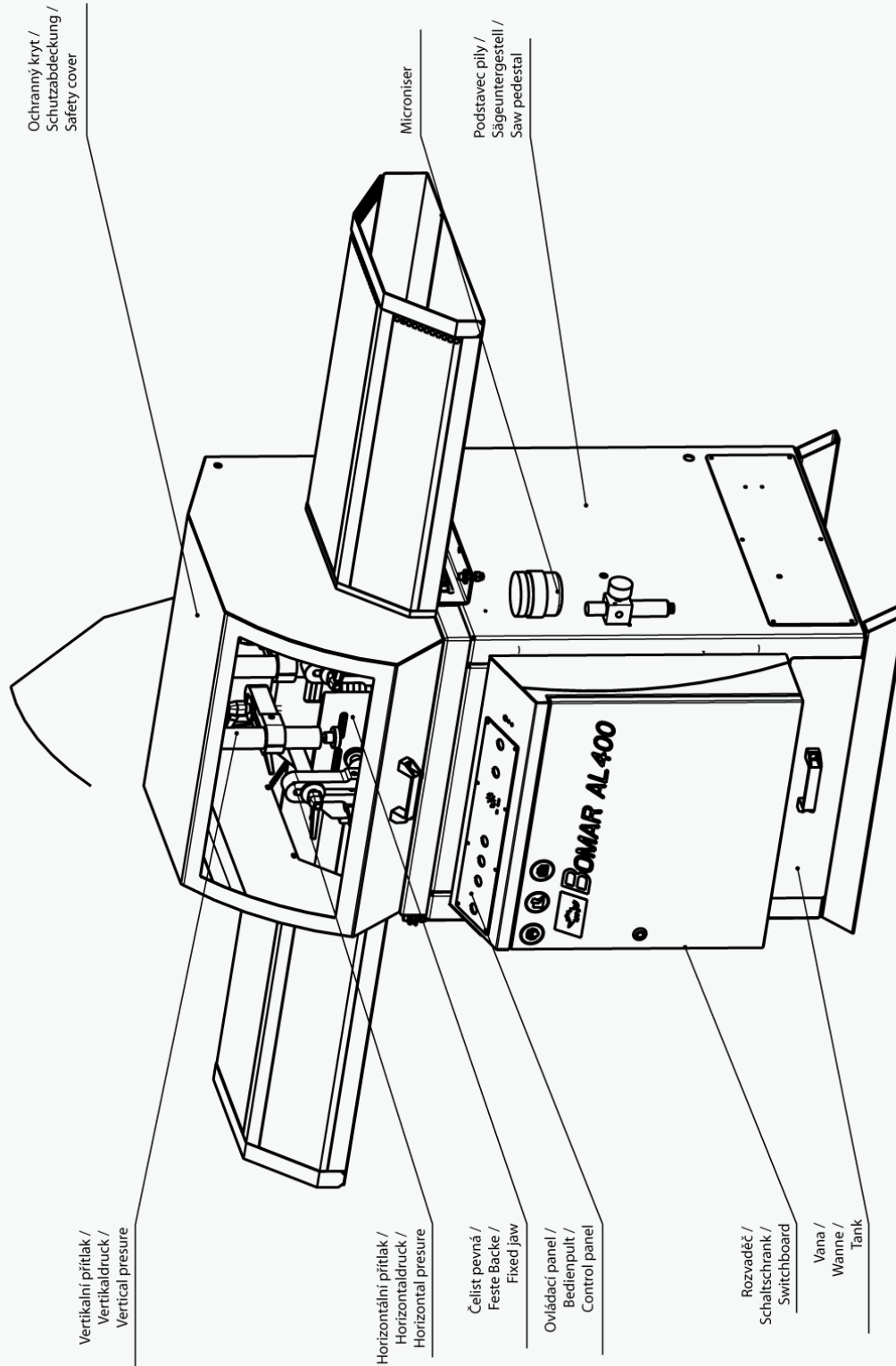

2.5. Transportation and stocking

2.5.1. Conditions for transportation and stocking

Keep recommendations for the manufacturers for transportation and stocking! If the recommendations are not kept, damage can occur to the machine.

- Don't use a forklift truck for handling the machine, if you do not have license for it!
- Don't move under suspended loads! Fault in lifting device may cause serious injury. Keep a safe distance from the machine during the transport.
- Temperature of the air from -25°C to 55°C , for a *short term* (max. 24 hours) temperature of the air until 70°C
- Do not expose the machine to radiation (for example microwave radiation, ultraviolet radiation, laser radiation, x-ray radiation). Radiation can cause problems with the machine function and deteriorating condition of the isolation.
- Take measures, to prevent damage by dampness, by vibrations and by shakes.

2.5.2. Transport and stocking preparations

- Close the vice and thoroughly oil all blank surfaces.
- Lower the saw frame to the lowest position.
- Fasten all loose parts securely to the machine.
- Pack and wrap the control desk securely to avoid damage during transport.

Fix the stickers stating the minimum approximate machine weight to at least five well visible places.

2.5.3. Transport and stocking

Handle the machine only with the hand pallet truck or the forklift truck! If the machine is equipped with the shackles in the pedestal, you can use the suspension cable and the crane.

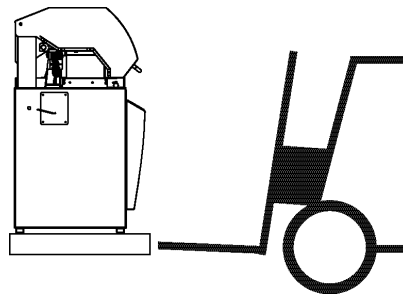

- Make sure that the hand pallet truck; the forklift truck or the crane had sufficient capacity.
- Make sure that the van or the trailer had sufficient capacity.
- The machine must be secured during transportation.
- Screw on the palette to the floor of the van or the trailer.
- Be careful that the machine is not damaged during transportation.

It is forbidden to handle the machine any other way, than it is written in this operating instructions, the machine can be damaged!

2.5.4. Transportní schéma /
Transport schema /
Transport scheme

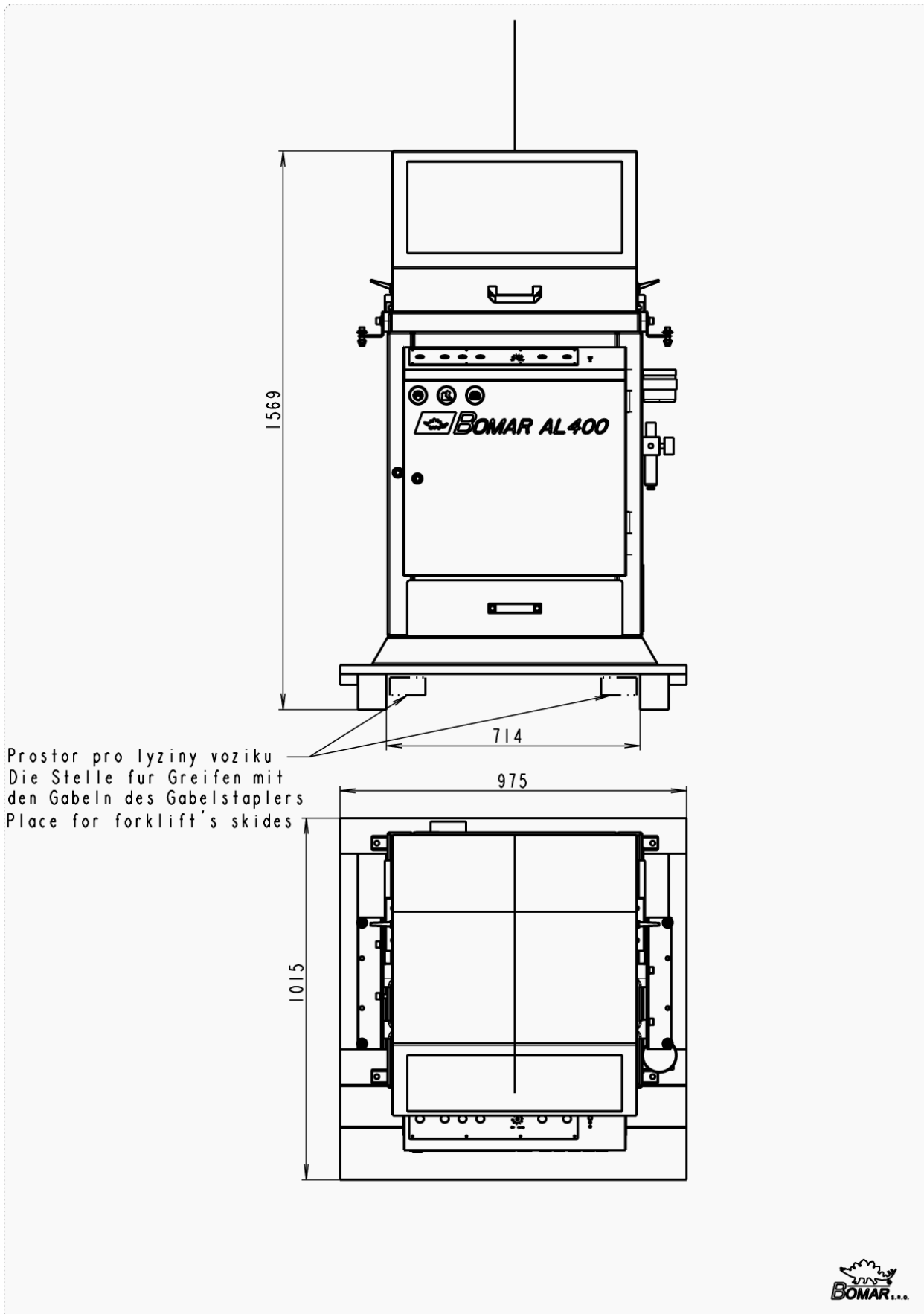

2.6. Activation

2.6.1. Machine working conditions

Keep the conditions of the manufacturer for machine operating! If recommendations are not kept, damage can occur to the machine.

The manufacturer warrants the correct function of the machine for these conditions:

- At temperature air from **10°C to 40°C**, the temperature average during 24 hours must **not exceed over 35°C**.
- At relative dampness of the air in the extend from 30% to 95% (not concentrate)
- Altitude lower than 1000 metres.
- Do not expose the machine to the radiation (for example microwave radiation, ultra-violet radiation, laser radiation, x-ray radiation). Radiation can cause problems with the machine function and deteriorating condition of the isolation.

2.7. Band saw unpacking and assembling

Remove the packing from the machine and unpack all parts.

Attention!

Switch off the main switch and lock it, before you start assembly! Otherwise, there is possibility of hazardous machine starting.

2.7.1. Machine installing and levelling

Check the floor supporting capacity before machine installing. If the floor capacity does not agree with requirements, you must prepare the necessary base for the machine.

Minimal requirement:

machine weight – AL 400 – 190 kg

+ weight of accessories

+ maximum weight of material

- The machine must be levelled at the horizontal position. All feet of the machine must touch with the floor after levelling
- The machine must be levelled by means of the calibrated spirit level. Spirit level is put on the vice area. Set the roller conveyors according to the spirit level.
- For machine levelling, take care that there is sufficient available space for operation, repair work, servicing of the machine and handling the material..
- The machine including appended parts and accessories must be visible from the place of operation.

2.7.2. Machine disposal after lifetime

Blown out all service fluids (cooling liquid, hydraulic oil) into designated reservoir. Dismantle machine into separate parts and dispose them in accordance with valid directives.

2.7.3. Kotevní plan / Verankerungsplan / Grounding plan

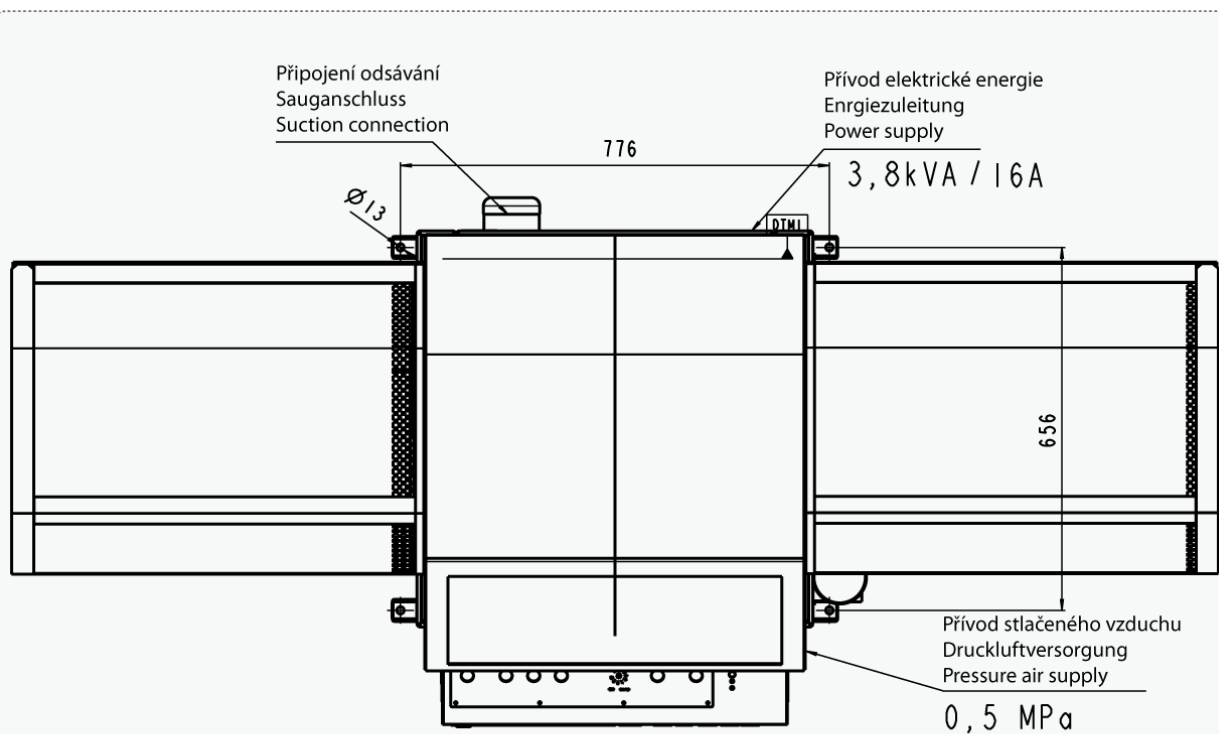

Kotvící materiál / Verankerungsmaterial / Grouding material

- **4x** Hmoždina / Dübel / Plug – **Ø12 mm**
- Vrtáno do hloubky / In die Tiefe gebohrt / Drilled to – **120 mm**
- Šrouby / Schraube / Screws – **4x M10**

Šrouby podložit deskami o min. rozměrech P10×100-100
 Die Schrauben mit Platten mit Minimaldimensionen P10×100-100 unterlegen
 Screws must be bottomed with plates (min. dimensions P10×100-100)

Požadavky na rovinnost podlahy / Anforderungen an die Bodenebenheit / Requirements for floor flatness

± 10 mm / 1 m

2.8. Electrical connection

Note:

The values of the crosscut of the conductor and the rated current are in the norms.

Electrical parameters of the machine:

- Service voltage: ~3 x 400 V (230 V), 50Hz, TN-C-S/TN-C (dep. on saw ver.)

Attention!

Only a qualified professional must carry out the servicing and repairs of the electric equipment! Take special care during work with electrical equipment. High voltage shock can have fatal consequences! Always keep notes about work safety.

- Total input/ Max. fuse: 3,8 kW / 16 A

Before connecting switch off the main switch of the power supply circuit for the machine and ensure dry place when doing connecting works!

Note:

The socket with the fork can be used only at the machines with the rated current less than 16 A and total input less than 3 kW.

Service voltage must agree with the line voltage! Crosscut of the supply line must respond with rated current for max. machine load.

Attention!

In this case the extra main switch becomes primary and the main switch on the machine has only secondary function.

In case the machine is connected with a direct connection, an extra main switch must be added which can be locked in zero position.

2.8.1. Check the running direction of the cutting wheel

After the machine has been successfully connected, briefly switch on the machine and put the driving engine of the cutting wheel in the running position. The direction must be in accordance with the arrow direction on the picture. In case the direction of the cutting wheel does not match, two phases at the terminal strip must be switched.

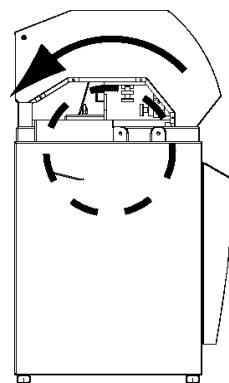

2.9. Connecting to the compressed air supply

Connect the machine to the compressed air supply by means of the screw **G1/4** on the manifold period according to the picture.



Compressed air must satisfy conditions:

- Roughly cleaned and partly dry.
- $p_{min} = 0,4 \text{ MPa}$
- $p_{max} = 0,6 \text{ MPa}$

2.10. Filling of the cooling system**Note:**

If the machine is equipped with Microniser, fill the Microniser container with prescribed cooling agent. Now is Microniser ready for operation.

2.11. Check machine function

Before starting the check machine functions, you must read the chapter „**Machine operation**“. Do not carry out check machine functions, if you do not comprehend meaning of all buttons and all machine functions.

Check, if the machine or some parts of the machine were not damaged during transport.

Check, if covers are installed and functional.

Switch on the main switch and check the motors and systems (saw disk drive etc.).

Open and close the vice. Turn the saw frame from one outer position to other outer position. Raise the frame to the top position and drop the frame to the lowest position.

Carry one cycle of cutting without material. Check, if the machine runs with no irregularities. If all machine functions are right, the machine is ready for operation.

2.12. Saw blade

Refit the saw band cover only after you have installed and tightened the saw band.

2.12.1. Saw blade size **$\text{Ø}400 \times \text{Ø}30 \times 3,6 \text{ mm}$**

The maximum cutting range of the machine is reached by using diving disk with recommended diameter. The usable qualities of the machine are lowered by using diving disk with fewer diameter.

Usage of the dividing disk with fewer diameter than 350 mm is not recommended!

2.12.2. Selection of the saw disk

The circular disk is possible to equip with dividing disks according to the material character and requirements on the quality of cut.

Look at the recommendation of your supplier when selecting the suitable dividing disk.

Note: *The machine is supplied without the saw disk.*



3. **Machine control**

3.1. Starting the saw

- »
- Switch on the main switch of the band saw. The main switch is situated on the side of the switchboard.



3.2. Control panel

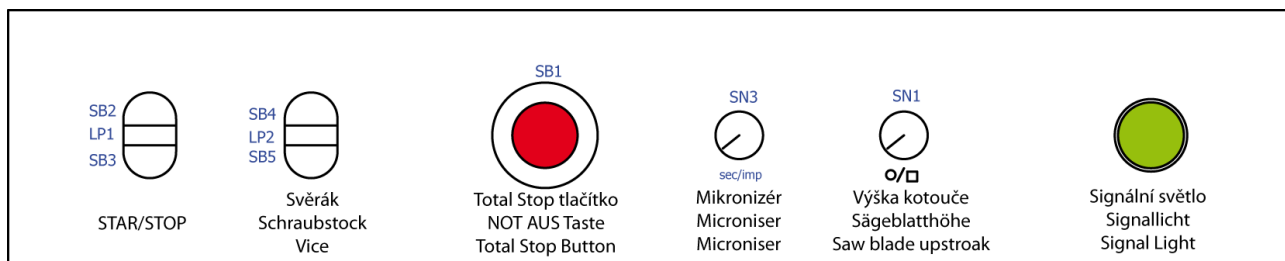

SB1	Emergency Stop Switch In case of emergency, the machine is stated to the order!
SB2	START / STOP
SB3	Press to start or stop machine working cycle.
SB4	Clamp / open vice
SB5	
SN3	Microniser Adjust the time between the two potions (injections) of cooling liquid (1-10 seconds). When the time between the two potions is shorter, the cooling is more intensive.
SN1	Adjusting wheel Turn to set the height of the circular-saw blade according to the profile of the cutting material.
	Control valve (not shown on picture) It adjusts the shift speed of the disk to the cut. Notice: If you keep closing the throttle valve too tightly, the valve seat may wear off which causes its leakage. Therefore, close the valve always gently.

3.3. Machine contro

3.3.1. Semi-automatic operation

1. Adjust the desired cutting angle.
2. Insert profile with the cover open.
3. Adjust height of circular blade with SN1 according of cutted profile

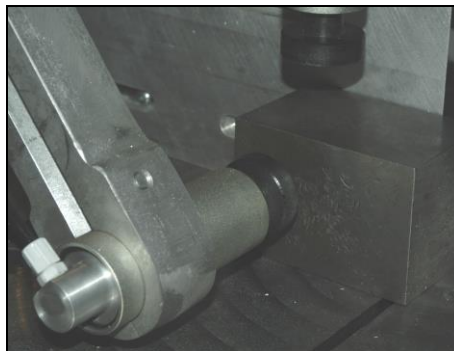

4. Set the clamping cylinder closest to the material (recommended value is 20 mm). If the clamping cylinders are further away from the material, the clamping takes longer.
5. Press and hold the button SB4 (clamping vice) for material clamping (the saw cover is still open). For security reasons, clamping pressure is limited, when is safety cover opened.
6. Close the saw cover.
7. By firstly pushing the START button (SB2) button, you can start the tool drive motor, which reaches the full speed after a certain time interval.
8. After the motor reaches the full speed, push the START button (SB2) again – the material will be clamped at full pressure and the cutting cycle will start.

Caution:

If you push the START button while the motor is starting up to the full speed, the cutting cycle will not start. In this case, push the START button again after a longer time interval.

9. The cycle is completed after cutting, saw cover is unlocked and materiál is released from vice.
10. Remove the material and the whole working cycle can be repeated.



Desired speed lifting arm to cut set by Control valve.

3.3.2. Signal light

- **Green** – upper cover unlocked
- **Red** – upper cover locked
- **Red blinking** – FAILURE (engine heat protection, opened covers, opened doors, Total Stop button)

3.3.3. Cycle breaking

The cycle can be stopped by 2 ways:

- Release both buttons **Cutting (1)** and press **STOP** button (button **5** – control panel) – the saw interrupts the actual cut, the saw arm lifts to the starting position and the saw disk drive stops.
- Press **Emergency Stop Switch** (button 3 – control panel) in emergency causes! The safety circuit is broken and the saw disk drive is stopped too.

3.4. Circular saw adjusting

3.4.1. Set of clamping cylinders

Security hole at maximum retract the rod.

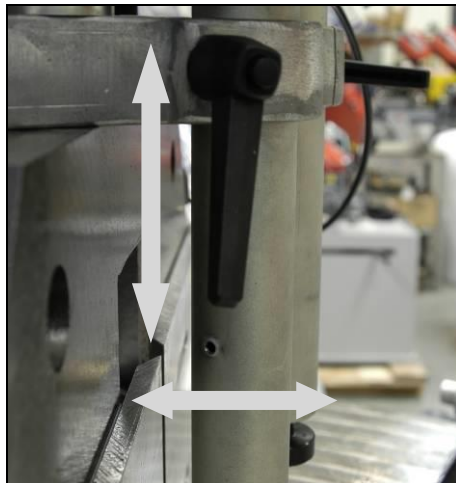

- When adjusting the height of the cylinder bore, the hole must be directed from the service. When removing the cylinder bore must be directed into the groove clamp.
- Material can be clamped main cylinder or two cylinders. Main clamping cylinder with a pressure switch (left from the perspective of the machine service)
- The cylinder can be adjusted from 20 mm to 100 mm from the cut material!
- If no possible clamping of the material at the maximum protrusion of clamping cylinders, not to run the operating cycle.

Attention!

If the main cylinder to clamp the material being cut off (eg. the table) can be runcycle.

3.4.2. Jaw console setting

Normally, the jaw console is situated in the front position. At cutting with 0° angle, the cutting range can be increased by shifting with console to the back.

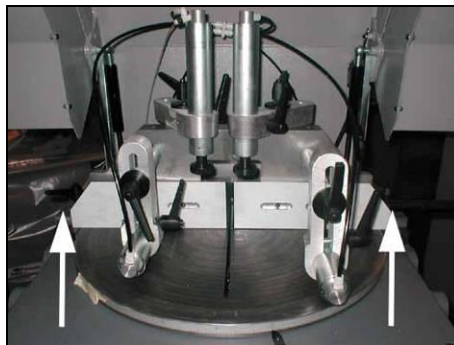

1. Loosen the tightening levers of the console.
2. Move the jaw console as far as the rear stops.
3. Tighten the securing levers of the jaw console.

ATTENTION! At angular cuts, console with jaws must be situated in front!

ATTENTION! With chips collector device installed on table, the cut angle can be varied from -60° to 60° .

ATTENTION! At angular cuts, console with jaws must be situated in front!

3.4.3. Angular cut setting

The cut angle can be varied from -60° (L60°) to $+90^\circ$ (R90°)

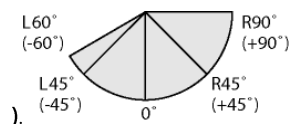

1. Release the securing lever of the turning console and adjust the desired cutting angle according to the scale.

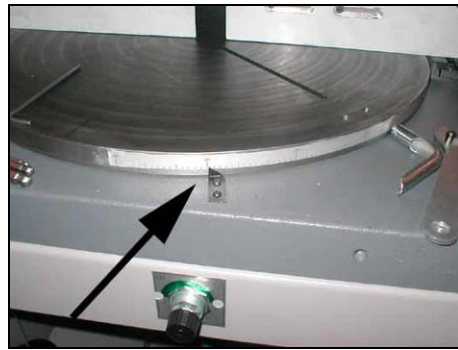

2. The scale is situated on the side of the turning console. Tighten again the securing levers of the turning console.

3.4.4. Clamping adjusting

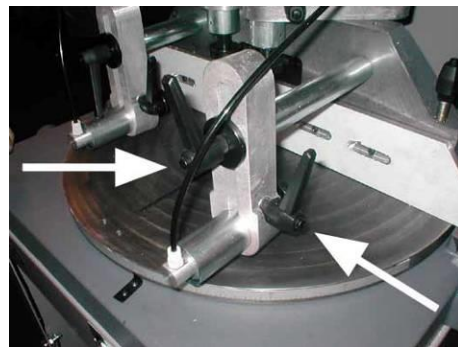

1. Release the securing lever of the clamping cylinder.
2. Shift the clamping cylinder. The clamping vice must be situated about 10 mm from the material.
3. Tighten again the securing lever.

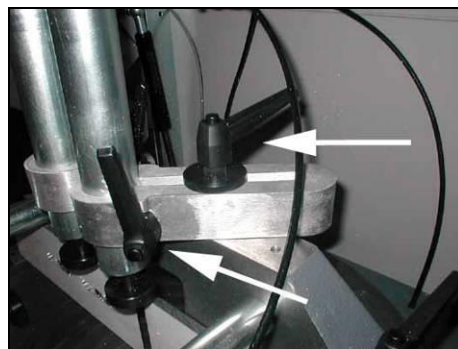

4. Adjust all four clamping cylinders.

3.4.5. Speed adjusting of the arm lowering

Set the speed of the arm lowering to the cut by control valve (position 7 – control panel).

- Set the **lower** speed of the arm lowering to the cut by turning the switch **clockwise**.
- Set the **higher** speed of the arm lowering to the cut by turning the switch **anti-clockwise**.

Notice: If you keep closing the throttle valve too tightly, the valve seat may wear off which causes its leakage. Therefore, close the valve always gently.

3.5. Suction device (optional accessory)

The suction set for the AL semi machines has **two suction outlets**.
The first outlet, installed at **the bottom of the machine**, provides for removal of chips from the blade directly.



The second outlet is located at the **top of the machine** behind the adjustable horizontal bridge.

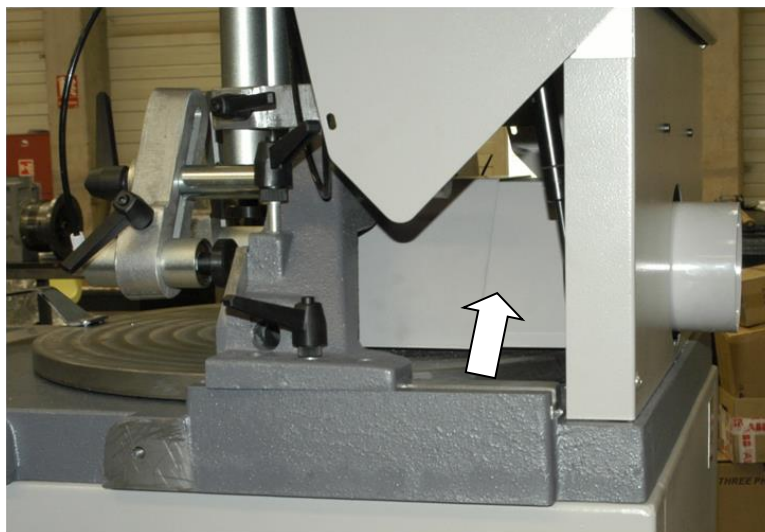

Each of these outlets is separately connected to the suction device by means of a flexible suction hose.

For sufficient exhaust output, it is necessary to ensure:

- correct installation of the suction set on the machine
- correct suction installation with the suction hose
- correct connection (fan rotation direction) of the suction device
- observance of the specified suction output (we recommend you to connect the suction set to a suction device of the Bomar company)
- each suction outlet must be connected to a separate suction device, with regard to a sufficient suction efficiency
- the suction efficiency is influenced by the amount of the micronizer cooling dose; with an increasing cooling dose, the chips are becoming heavier, with which the efficiency decreases
- every machine is also equipped with the drawer for removal of chips at the bottom; which must be emptied regularly during operation of the machine

3.6. Material insertion

- Never walk under a suspended load!
- Never climb onto the gravity-roller conveyor!
- Do not hold the material for clamping material to the vice! The vice can cause injury!

3.6.1. Handling agent selection

- Use the strong handling agents to lift and transfer the material!
- Handle with the material only with the lift truck or use the suspension strands and the crane!
- Do not use the lift truck or crane in case that you do not have the license to handle with it!

3.6.2. Insertion

Insert material to the vice and ensure that the material cannot move in the vice or fall from the vice after the clamping. If you cut long pieces of the material (for example rod, tube), you must use the roller conveyors for material shifting to the band saw. Contact Bomar for more information about roller conveyors

Make sure the conveyor is long enough and the material cannot tip off the conveyor.

Be especially careful with round materials that it always stays on two vertical rollers and that it cannot fall off the conveyor!

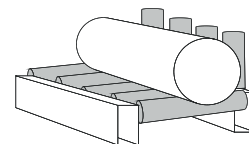

4. **Machine maintenance**

4.1. Saw disk dismantling

WARNING!

After switching off the machine, the blade will still rotate for at least one minute. **Opening the door in this time is not allowed and can cause serious injuries!**

Doors are secured with a lock. Approximately 50 s after the last cutting machine doors are unlocked. The machine must be connected to the network and turned on



1. Wait for the door unlock and open it. Saw is switch ON.
2. Switch the main switch off.



3. If your saw has exhausting device installed, before removing saw blade, remove exhausting device from blade. Dismount plastic screw.

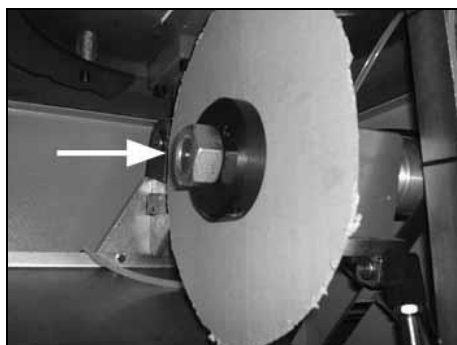

4. Loose the nut, get off the washer and the saw disk.

4.2. Saw disk installation

1. Prior to installation, clean the shaft thoroughly of all traces of chips and dirt. Keep in mind **the teeth direction when installing the saw disk.**
2. Put on the saw disk and the washer. Tighten the nut fast.
3. Close the door at the pedestal.
4. Switch the main switch on. The circular saw is set up.

4.3. Cooling agents and chips disposal

The quality of the cooling agent will deteriorate due to:	If the solution is too weak:	If the solution is too strong:
<ul style="list-style-type: none"> • use of contaminated water • impurity • outside oil contamination (hydraulics, gears) • high operating temperatures • lack of air circulation • wrong concentration 	<ul style="list-style-type: none"> • corrosion protection is diminished • lubrication decreases • microbial attack is more likely 	<ul style="list-style-type: none"> • the cooling ability is decreased • foam behaviour increases • emulsions stability deteriorates • sticky residue develops

4.3.1. Cooling liquid inspection

Check the state of the cooling liquid periodically. Keep notes in chapter **Cooling agents and chips removal** for state checking and cooling liquid filling.

If the cooling liquid is little in the tank, it can cause the damage of the saw disk by influence of insufficient cooling.

The excess liquid can overflow from the tank on the floor, the service worker can slide and he can injure.

4.3.2. Chips disposal

Chips resulting from cutting operations must be disposed of in accordance with the relevant regulations.

- Let the chips drip excess fluid!
- Fill a watertight container with the chips! Be careful that the container does not leak, because even after a long dripping time, they still contain coolant residue.
- *Place the container into the care of a disposal company equipped for the disposal of chips contaminated with cooling liquid.* In case the machine is equipped with micro-spray installation, the chips must also be handed over to a disposal company.

4.4. Hydraulic, Greases and oils

4.4.1. Lubricant greases

We recommend using lithium based saponified grease, class NGLI-2 for lubrication. Different greases are mixable, if their oil bases and consistence type are identical.

Comparative table of the lubricant greases:

Manufacturer	Type of the lubricant grease
BP	Energrease LS - EP
DEA	Paragon EP1
Esso	FETT EGL 3144
	Beacon EP 1
	Beacon EP 2
FINA	FINA LICAL M12
Klüber	Microlube GB0
	Staburags NBU8EP
	Isoplex Spezial
Optimol	Optimol Longtime PD 0, PD1, PD2
Shell Aseol AG	ASEOL Litea EP 806-077
Texaco	Multifak EP1

4.4.2. Lubrication

There are several places on the machine, which are necessary to grease periodically. It secures the right function of the machine.

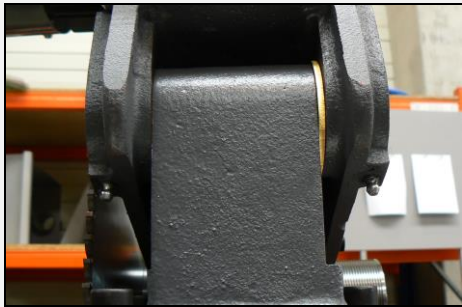
Lubrication place	Lubrication
	<p>Concole of the saw arm – lubricate with grease once per month (see chapter Lubricant greases). Use 3-5g grease on the every carriage of the linear guiding. Use the grease gun to the lubrication. Drive 3-5 times whole line of the linear guiding during lubrication.</p>

4.4.3. Hydraulic oils

Replace the hydraulic oil once in 2 years, because the oil can deteriorate its properties and cause problems the hydraulic equipment. If the hydraulic system is equipped with filter (2SF 56/48-0,063), replace the filter too.

Use oils with specification DIN 51524-HLP, ISO 6743-4 and viscosity grade ISO VG 32 in hydraulic aggregates. Hydraulic oils quantity – see chapter **Hydraulic oil level check**.

Note:

When replacing, use oils recommended by BOMAR or oils, which has comparable parameters from the other manufacturers. Do not forget, that mineral and synthetic oils may not be mixed!

Comparative table of the hydraulic oils

Manufacturer	Type	Manufacturer	Type
Agip	Oso 32	Ina	Hidraol 32 HD
Aral	Vitam GF 32	Klüber	Lamora HLP 32
Avia	Avilub RSL 32	Hungary	Hidrokomol P 32
Benzina	OH-HM 32	Mobil	Mobil DTE 25
BP	Energol HLP 32	ÖMV	HLP 32
Bulgaria	MX-M/32	Poland	Hydrol 30
Castrol	Hyspin AWS 32	Rumania	H 32 EP
Čepro	Mogul HM 32	Russia	IGP 30
DEA	Astron HLP 4hy6	Shell	Tellus Oil 32
Elf	Elfolna 32	Sun	Sunvis 832 WR
Esso	Nuto H 32	Texaco	Rando HD B 32
Fam	HD 5040	Valvoline	Ultramax AW 32
Fina	Hydran 32		

4.4.4. Hydraulic oil level check

Open the door at the pedestal and check the state of the oil. The oil level must be situated between marks **min** and **max**.

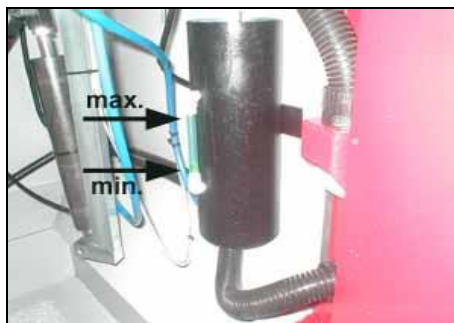

Fill the hydraulic oil, if it is necessary. Use always the filter (10 μm or better) when you fill the oil. You avoid impurities penetration to the hydraulic system and troubles in hydraulic system.

4.5. Pressure system servicing

Filter of the pressure system is necessary to clean periodically, that means drain sediments and impurities from the reservoir.

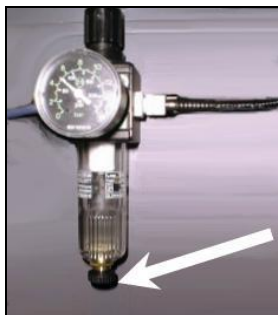

Screw off the screw and let to drain sediments to the reservoir. Screw on the screw again.

WARNING!

There is a pressure 0,5 – 0,6 MPa in the system, therefore you must release the screw very carefully!

4.6. Machine cleaning

Clean the machine from the cooling liquid and impurities after every shift stopping. Conserve the guiding surfaces, mainly:

- Clamping jaws of the vice.
- The guiding of the jaws' console.
- Loading surface and area in the pedestal.

4.7. Worn pieces replacement

4.7.1. Belt replacement

1. Switch off the machine main switch.
2. Open the door on the pedestal.

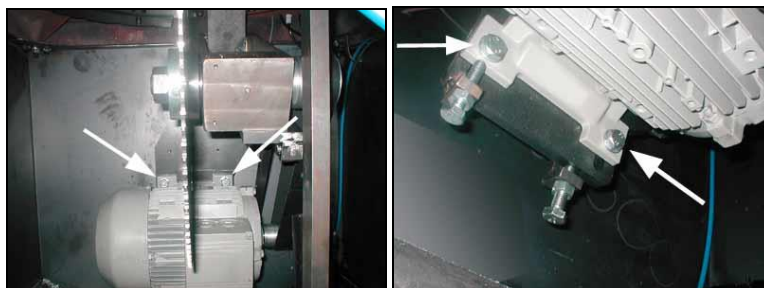

3. Release 4 screws, which holds the electromotor.

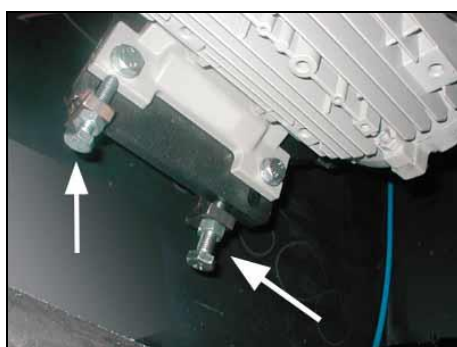

4. Release nuts of the stretching screws and screw off both screws, until the belt is not released.

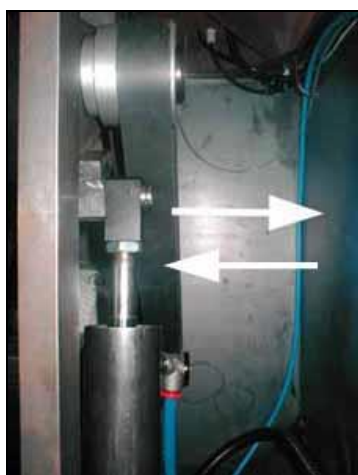

5. Remove worn driving belt and put on the new.

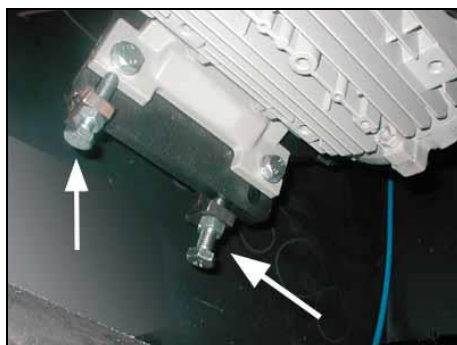

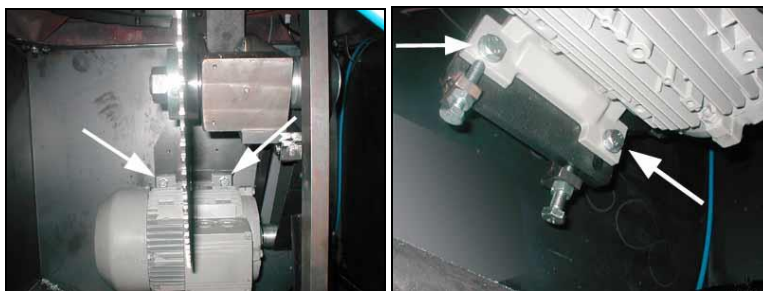

6. Stretch the driving belt by means of the stretching screws and tighten nuts of the stretching screws again.



7. Tighten 4 screws, which holds electromotor.
8. Close the door on the pedestal and switch on the main switch. Belt replacement is finished.

5. Schematics

5.1. Elektrické schéma /Elektroschema /Wiring diagrams –
s frekv. měničem / mit Frequenzumrichter / without
frequency convertor 3×400 V+PE,50Hz

0	1	2	3	4	5	6	7	8	9	
 <p>BOMAR, spol. s r.o. Těžební 1236/1 627 00 Brno Czech republic</p> <p>AL 400 semiautomatic ES-K110F-201/202-V4.3 Wiring diagram 3x400V + PE, 50Hz</p>										
 <p>BOMAR, s.r.o. Těžební 1236/1 CZ 627 00, Brno</p>		<p>Spis/Mechine/Maschine: AL 400 semiautomatic</p>		<p>Název stránky/Name page/Name seiten: Úvodní strana/ Start page/ Startseite</p>			<p>Číslo dok./Doc.No./Anzahl der Dokumente: ES-K110F-201/202-V4.3 Měkajken/Power supply/E.rspe.instanz: 3x400V + PE, 50Hz Zpracova./Processed./Mit verarbeitet: Kosska Datum/Dang/batum.: 20.4.2015</p>		<p>L.ist/Page/ Seite: 00 L.ist/Reihe/ Seite: 15</p>	

0	1	2	3	4	5	6	7	8	9
Table of contents									
Page	Page name								Date
00	Úvodní strana/ Start page/ Startseite								20.4.2015
01	Obsah/ Table of contents/ Inhaltsverzeichnis								20.4.2015
02	I/O řídicí systém / I/O Control station / I/O Steuerung								25.6.2014
03	Umístění prvků v rozváděči/Element lay-out in the distributor/Platzierung der Geräte im Schaltschrank								25.6.2014
03.a	Ovládací panel/Control Panel/Steuerpult								25.6.2014
04	Kusovník artiklů/ Parts list/ Artikelstückliste								20.4.2015
04.a	Kusovník artiklů/ Parts list/ Artikelstückliste								20.4.2015
05	Silová část/Power part/Feld partie								20.4.2015
06	Ovládací část - vstupy/Control device - inputs/Staereinheit - Eingänge								20.4.2015
06.a	Ovládací část - vstupy/Control device - inputs/Staereinheit - Eingänge								25.6.2014
07	Ovládací část - výstupy/Control device - outputs/Staereinheit - Ausgänge								25.6.2014
08	Ovládací část/Control device/Staereinheit								25.6.2014
09	Řídicí systémy/Control systems/Steuersystem								20.4.2015
10	Komunikace MIMCA/Communication MIMCA/Kommunikation MIMCA								20.4.2015

00



BOMAR, s.r.o.
 Třeborní 1236/1
 CZ 627 00, Brno

Společnost/Machine:
AL 400 semiautomatic

Název stránky/Name page/Name seite:
 Obsah/ Table of contents/ Inhaltsverzeichnis

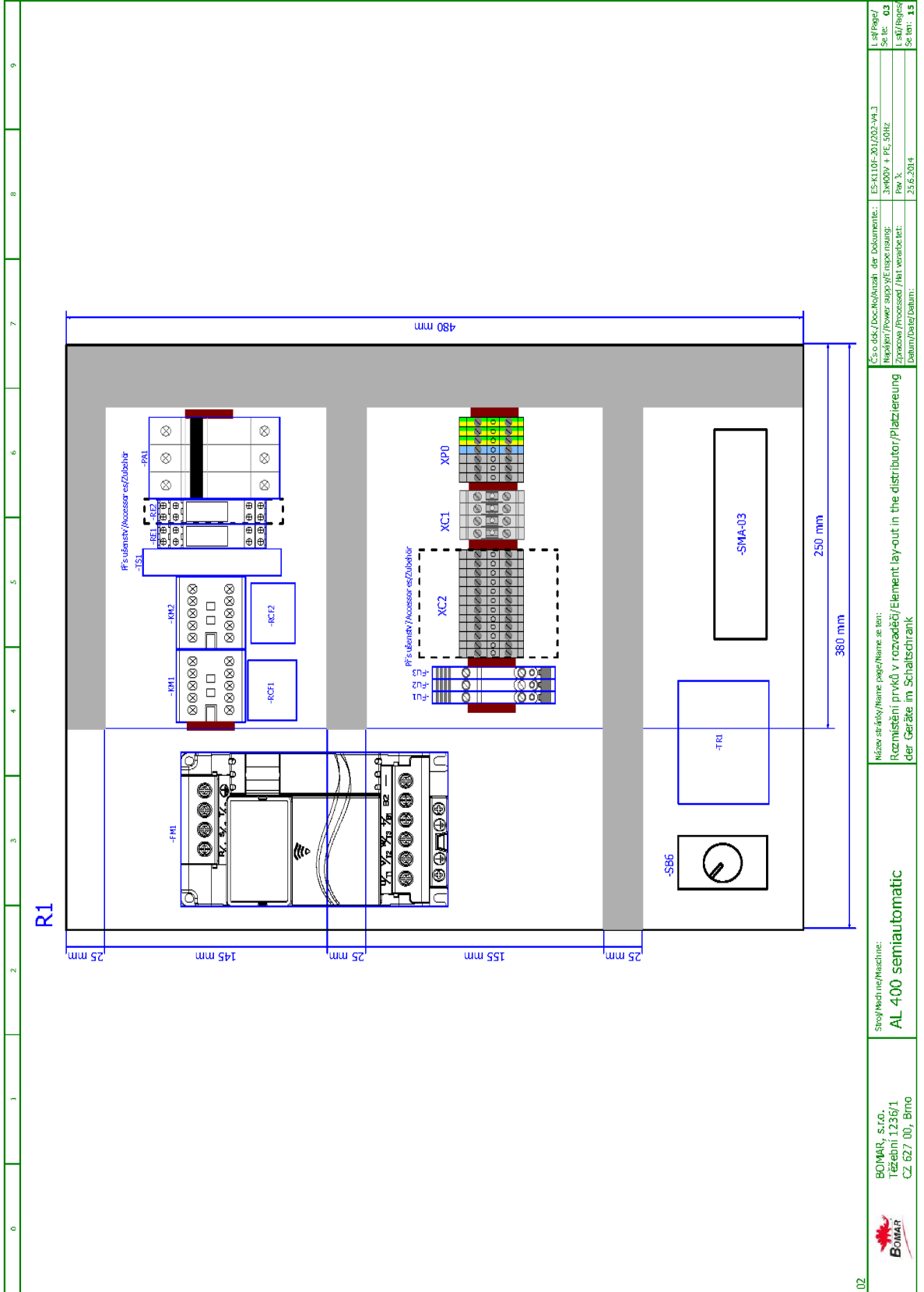

Číslo dok./Doc.No./Anzahl der Dokumente: ES-K10F-201/202-V4.3
 Napájení/Power supply/Energieanschl.: 3x000V + PE, 50Hz
 Zpracováno/Processed/ Mit verarbeitet: Kaska
 Datum/Datum/ Datum: 20.4.2015

L.Š./Page/
 Se. It.: **01**
 L.Š./Reprint/
 Se. It.: **15**

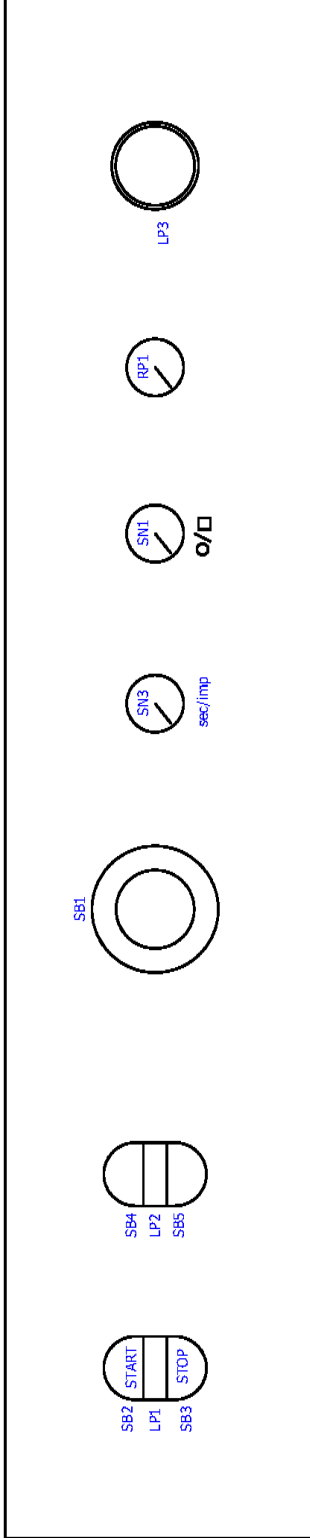

02

<p>BOMAR, s.r.o. Třebetín 1236/1 CZ 627 00, Brno</p>	<p>Stroj/Mechine/Machine: AL 400 semiautomatic</p>	<p>Název stránky/Name page/Name of sheet: Rozměstění prvků v rozvaděči/Element layout in the distributor/Platzierung der Geräte im Schaltschrank</p>	<p>Číslo dok./Doc.No./Název der Dokumenten.: ES-K110F-201/202-V4.3 Měřítko/Power supply/Einspeisung: 3x400V + PE, 50Hz Zpracováno/Processed / Mit verarbeitet: Per. N. Datum/Dating/datum: 25.6.2014</p>
			<p>L. sif/Page/ Se. It.: 03 L. sif/Requisit/ Se. It.: 15</p>

0	1	2	3	4	5	6	7	8	9		
<p>OPI</p> 											
 BOMAR, s.r.o. Třebetín 1236/1 CZ 627 00, Brno				Spoj/Mechine/Maschine: AL 400 semiautomatic				Název stránky/Name page/Name seiten: Ovládací panel/Control Panel/Steuerpult		Číslo dok./Doc.No/Anzahl der Dokumenten.: ES-K10F-201/02-V4.3 Repakty/Power supply/Einspeisung: 3x400V + PE, 50Hz Zpracova./Processed./Mit verarbeitet.: Per. X. Datum/Datum: 23.6.2014	
				L. sít/Pages/ Str. Nr.: 03		L. sít/Pages/ Str. Nr.:		L. sít/Pages/ Str. Nr.: 15			

0	1	2	3	4	5	6	7	8	9
Parts list									
Device identification	Device description	Type number	Manufacturer	Part number	Quantity	Location (page,column)			
-CU1	Control unit SMA 3.X	SMA 3.X	BOMAR s.r.o.	91.985.222	1	/09.1			
-FM1	Frequency converter - 3.7kW, 3x400VAC	VFD037E43A	DELTA ELECTRONICS, INC.	91.012.094	1	/05.2			
-FU1	Fuse terminal	WK4JTHSISU	WIELAND	91.251.102	1	/05.6			
-FU1	Tube fuse - 1A/250V, slow, 5x20	T1A/250V	ESKA	91.230.031	1	/05.6			
-FU2	Fuse terminal	WK4JTHSISU	WIELAND	91.251.102	1	/05.6			
-FU2	Tube fuse - 1A/250V, slow, 5x20	T1A/250V	ESKA	91.230.031	1	/05.6			
-FU3	Tube fuse - 4A/250V, slow, 5x20	T4A/250V	ESKA	91.230.015	1	/05.8			
-FU3	Fuse terminal	WK4JTHSISU	WIELAND	91.251.102	1	/05.8			
-KM1	Mini contactor - 4kW/400V, 3P	B65-30-01-1.7-71	ABB	91.040.049	1	/06.a.7			
-KM2	Mini contactor - 4kW/400V, 3P	B65-30-01-1.7-71	ABB	91.040.049	1	/06.a.8			
-LP1	The head backlight buttons white	M22-DL-W	EATON	91.060.038	1	/07.1			
-LP2	White light for Eaton adapter	M22-LED-W	EATON	91.061.034	1	/07.0			
-LP3/1	LED red and green common ground 24V DC	HIS-95 G/R 24V DC	ELECO	91.060.069	1	/07.2			
-PA1	Fuse disconnecter E-90 - 3P	E 93/32	ABB	91.241.014	1	/05.2			
-PA1	Tube fuse - 12A, 10x38, fast	PV10 12A gG	OEZ	91.231.007	3	/05.2			
-QS1	Disconnecter - 3P, 16A	OT16FT3	ABB	91.170.018	1	/05.1			
-QS1	Handle switch - black	OHBS3RH	ABB	91.180.016	1	/05.1			
-RCF1	Efferent RFC filter	F80PRL624	Ing. Miroslav Vítěk	91.041.015	1	/05.1			
-RCF2	Efferent RFC filter	F80PRL624	Ing. Miroslav Vítěk	91.041.015	1	/05.1			
-RE1	Plug-in relay	CR-P024DC2	ABB	91.051.049	1	/06.a.5			
-RE1	Relay socket	CR-PSS	ABB	91.051.048	1	/06.a.5			
-RE2	Plug-in relay	CR-P024DC2	ABB	91.051.049	1	/07.8			
-RE2	Relay socket	CR-PSS	ABB	91.051.048	1	/07.8			
-RP1	Potentiometer 4k7	TP195-4k7/N20A	GES-ELECTRONICS, a.s.	91.283.015	1	/05.6			
-RP1	Head of potentiometer 24mm	S8877 BLK	GES-ELECTRONICS, a.s.	91.060.063	1	/05.6			
-RP1	Fastconnect clamp	WAGO 224-112	WAGO	91.250.009	3	/05.6			
-SB1	Emergency-stop mushroom push - button + 3xNC	YW1B-V4E02R	IDEC	91.060.084	1	/06.5			
-SB2	Double button head white/black-start/stop	M22-DDL-W5-G51/G50	EATON	91.060.034	1	/06.2			

The manufacturer reserves right to use an equivalent replacement device.

03.a	BOMAR, s.r.o. Třebetín 1236/1 CZ 627 00, Brno	Stroj/Mechine/Machine: AL 400 semiautomatic	Název stránky/Name page/Name se ten: Kusovník artiklů/ Parts list/ Artikelstückliste	Číslo dok./Doc./Anzahl der Dokumenten.: ES-K10F-201/02-V4.3 Název/power supply/E resp. nuzing.: 3x400V + PE, 50Hz Zpracováno/Processed / Mit verarbeitet.: Kosska Datum/Date/datum.: 20.4.2015	LH/Page/ Se. te.: 04 L. s. /Requis/ Se. ten.: 15
------	---	---	---	---	---

0	1	2	3	4	5	6	7	8	9
Parts list									
Device identification	Device description	Type number	Manufacturer	Part number	Quantity	Location (page,column)			
-SB2	Attaching adapter + 1NO	M22-AK10	EATON	91.061.021	1	/06.2			
-SB3	NO contact for Eaton adapter	M22-K10	EATON	91.061.022	1	/06.1			
-SB4	Double button head white/black, arrow close/open	M22-DDL-WS-*	EATON	91.060.055	1	/06.3			
-SB4	Attaching adapter + 1NO	M22-AK10	EATON	91.061.021	1	/06.3			
-SB5	NO contact for Eaton adapter	M22-K10	EATON	91.061.022	1	/06.4			
-SB6/1	Attaching adapter + 1NC	M22-AK01	EATON	91.061.020	1	/06.a.5			
-SB6/1	Switch 2 positions	M22 - WRKV	EATON	91.060.037	2	/06.a.5			
-SB6/2	NC contact for Eaton adapter	M22-K01	EATON	91.061.024	1	/06.a.8			
-SB6/3	NO contact for Eaton adapter	M22-K10	EATON	91.061.022	1	/06.6			
-SW1	Potentiometer 4k7	TP195 4k7/N20A	GES-ELECTRONICS, a.s.	91.283.015	1	/06.8			
-SW1	Head of potentiometer 24mm	S8877 BLK	GES-ELECTRONICS, a.s.	91.060.063	1	/06.8			
-SW1	Fastconnect clamp	WAGO 224-112	WAGO	91.250.009	3	/06.8			
-SW2	Position measuring	DH-RAIM	Bomar	262.012	1	/06.7			
-SW3	Potentiometer 4k7	TP195 4k7/N20A	GES-ELECTRONICS, a.s.	91.283.015	1	/06.8			
-SW3	Head of potentiometer 24mm	S8877 BLK	GES-ELECTRONICS, a.s.	91.060.063	1	/06.8			
-SW3	Fastconnect clamp	WAGO 224-112	WAGO	91.250.009	3	/06.8			
-SQ1	Head	ZCE10	TELEMECANIQUE	91.061.201	1	/06.a.0			
-SQ1	The switch body	ZCD31	TELEMECANIQUE	91.061.202	1	/06.a.0			
-SQ1	Cable gland	ZCDEG11	TELEMECANIQUE	91.061.203	1	/06.a.0			
-SQ2	Safety Limit Switch with 24V coil	D4NL-4HFA-B	OMRON	91.173.040	1	/08.3			
-SQ3	Safety Limit Switch with 24V coil	D4NL-4HFA-B	OMRON	91.173.040	1	/07.4			
-TR1	Toroidal transformer - 400V / 230V / 20V 4,5A 90VA	400V/230V/20V 4,5A 90VA	KARBAN s.r.o.	91.060.023	1	/05.7			
-TS1	Multifunction time relay - 12-240V, 10 functions	CRM-91H/UNI	ELKO	91.051.027	1	/08.1			

The manufacturer reserves right to use an equivalent replacement device.

04	BOMAR, s.r.o. Třebetín 1236/1 CZ 627 00, Brno	Spotřeba/Mechanism: AL 400 semiautomatic	Název stránky/Name page/Name seiten: Kusovník artiklů/ Parts list/ Artikelstückliste	CS o dok./DocNo/Anzahl der Dokumenten.: ES-K10F-301/202-VH-3 Hagyó/Power supply/Einspeisung: 3~380V + PE, 50Hz Zpracováno/Processed /Hft. verarbeitet: Koska Datum/Dating/datum: 20.4.2015	L. 84/Pagel/ Seite: 04 L. 84/Regist/ Seiten: 15
----	---	--	---	---	---

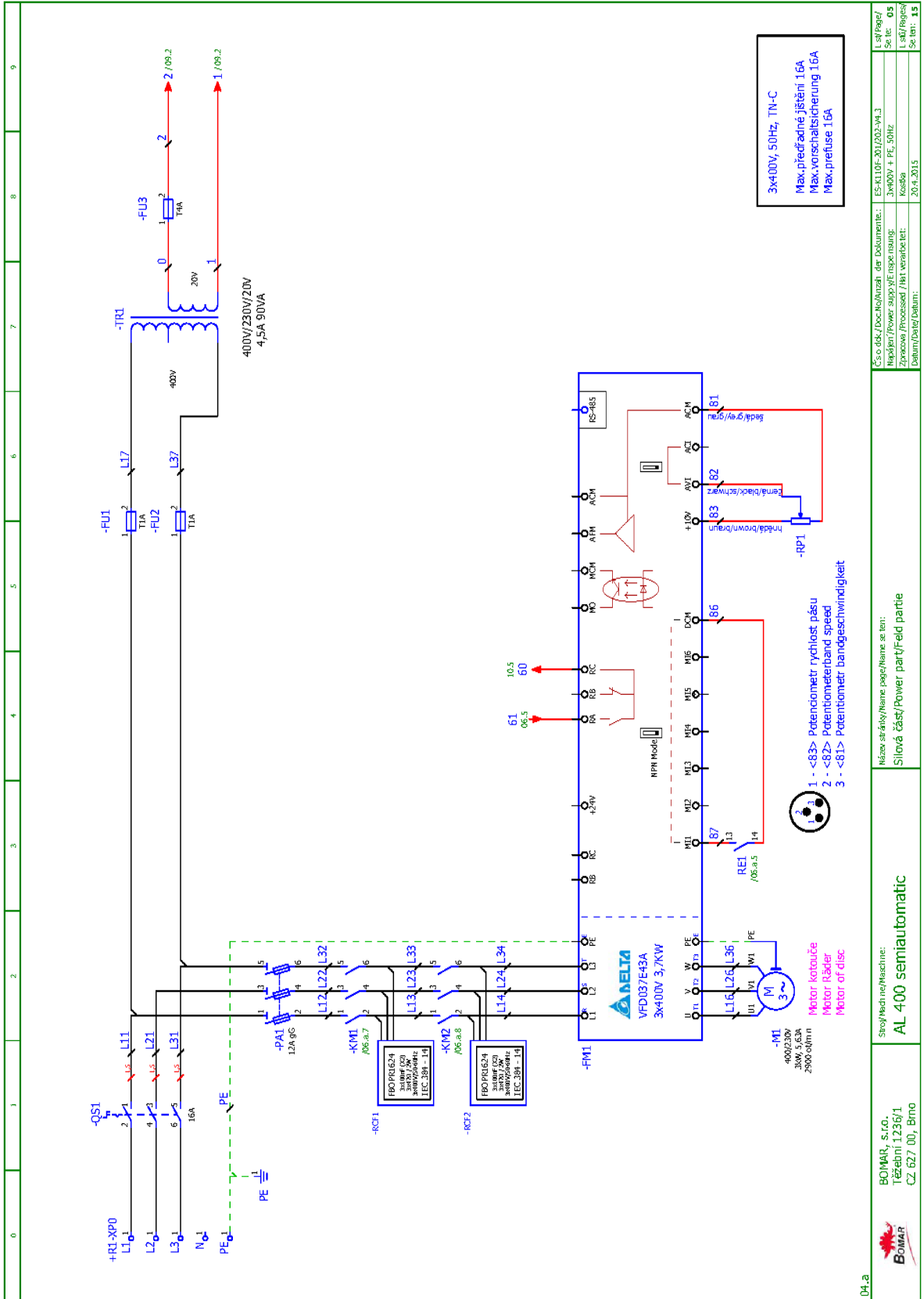

0	1	2	3	4	5	6	7	8	9
<p>ÚH_a</p> <p>BOMAR, s.r.o. Třebonín 1236/1 CZ 627 00, Brno</p> <p>Stroj/Mechine/Machine: AL 400 semiautomatic</p> <p>Název strojů/Name page/Name se ten: Silová část/Power part/Feld partie</p> <p>ÚS o.d.k./Doc.No/Anzahl der Dokumentte: ES-K10F-201/02-V4.3</p> <p>Regeljen/Power supply/E respce instanz: 3x400V + PE, 50Hz</p> <p>Zpracove /Processed / Mit verarbeitet: Koska</p> <p>Datum/Dating/datum: 20.4.2015</p> <p>Lst/Page/ Se. It: 05</p> <p>Lst/Reise/ Se. It: 15</p>									

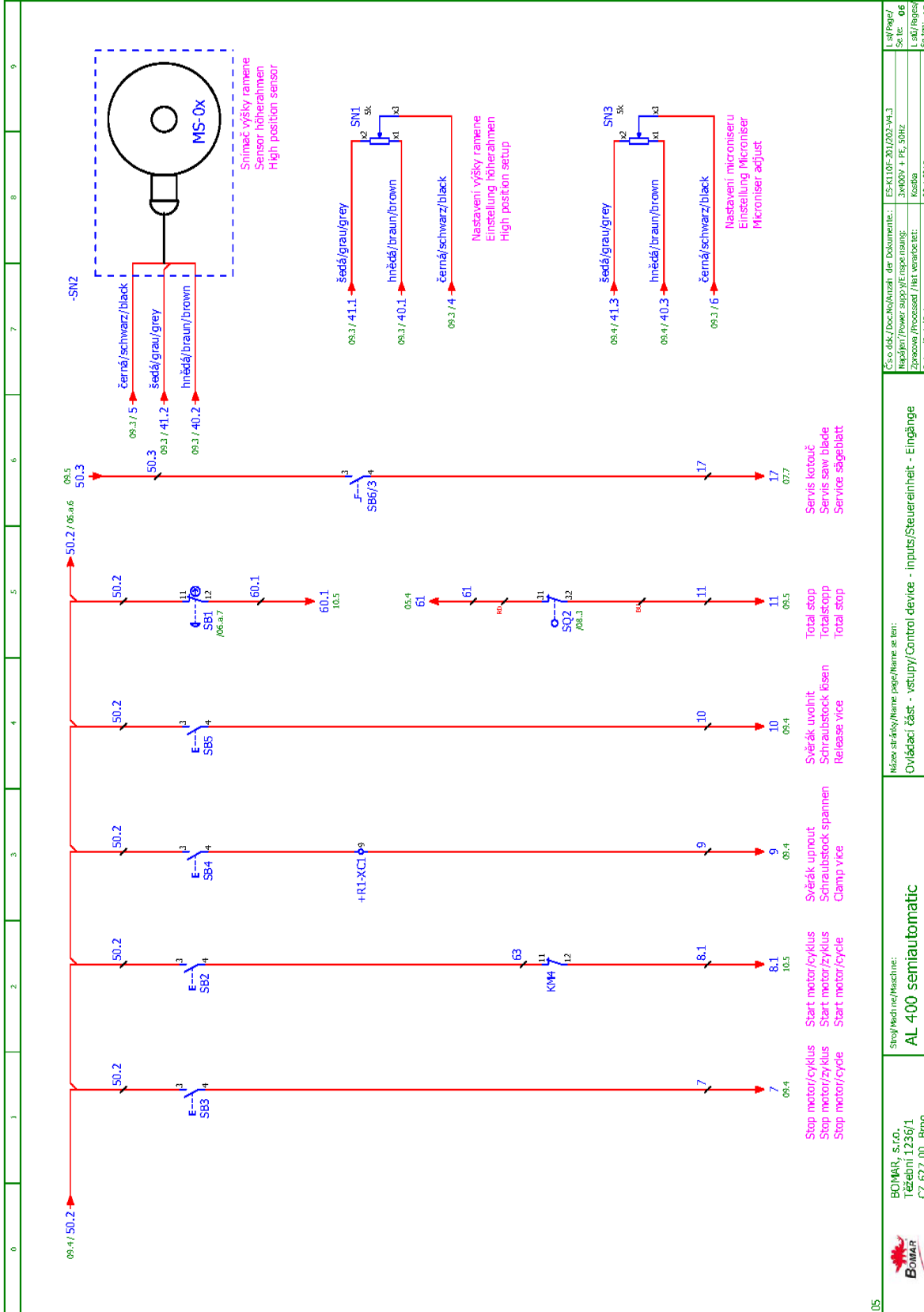

05

<p>BOMAR, s.r.o. Třeborní 1236/1 CZ 627 00, Brno</p>		<p>Společnost/Name: AL 400 semiautomatic</p>		<p>Název stránky/Name page/frame: Ovládací část - vstupní/control device - inputs/Steuerinheit - Eingänge</p>		<p>ES o.d.k./DocNo/Verz. der Dokument: ES-K10F-201202-V4.3 Napájení/Power supply/Energie: 3x00V + PE, 50Hz Zpracováno/Processed / Mit verarbeitet: Kaska Datum/Dating/Date: 20.4.2015</p>	
		<p>Sheet/Page: 06</p>		<p>Site: 06</p>		<p>Sheet/Page: 15</p>	

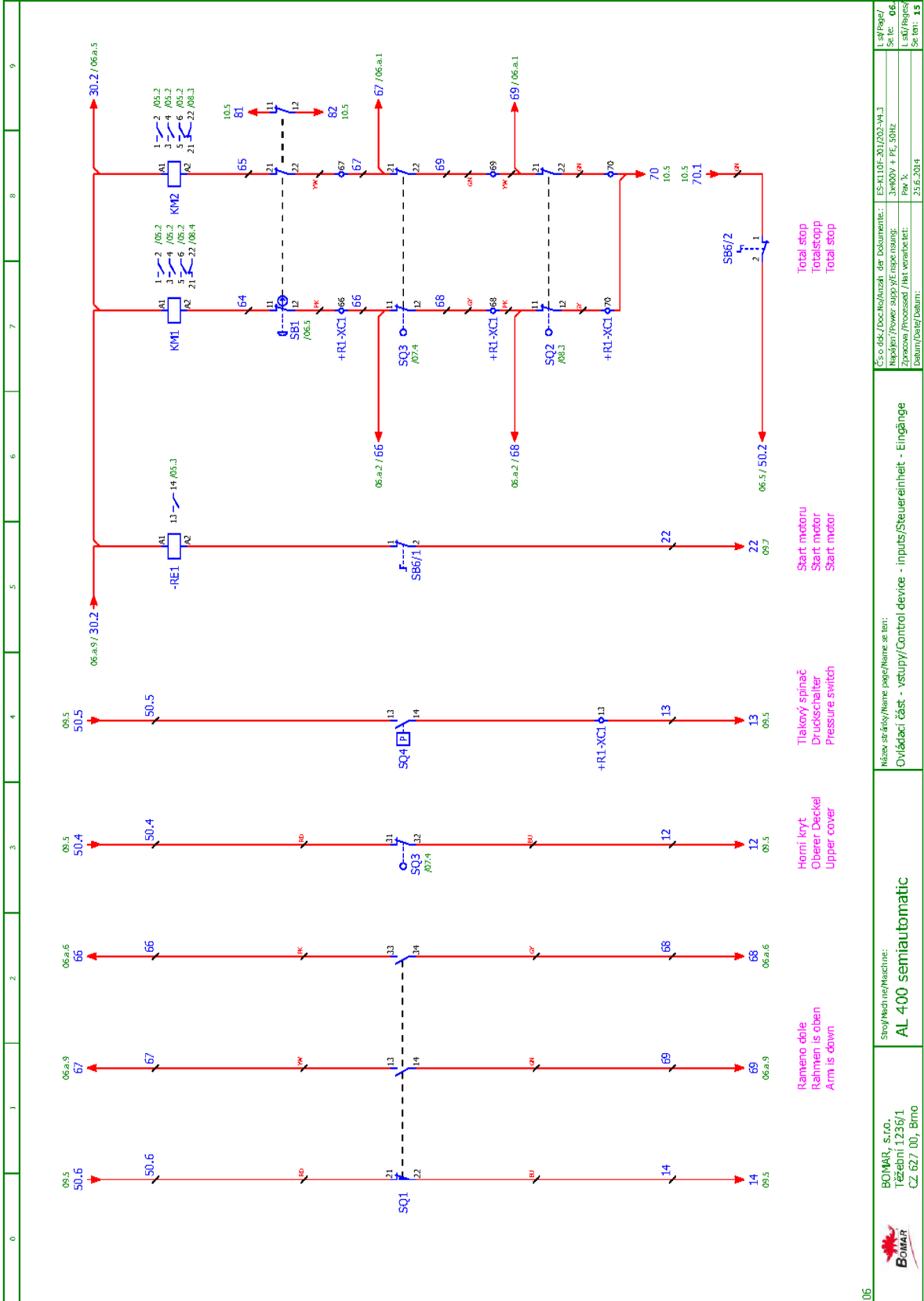

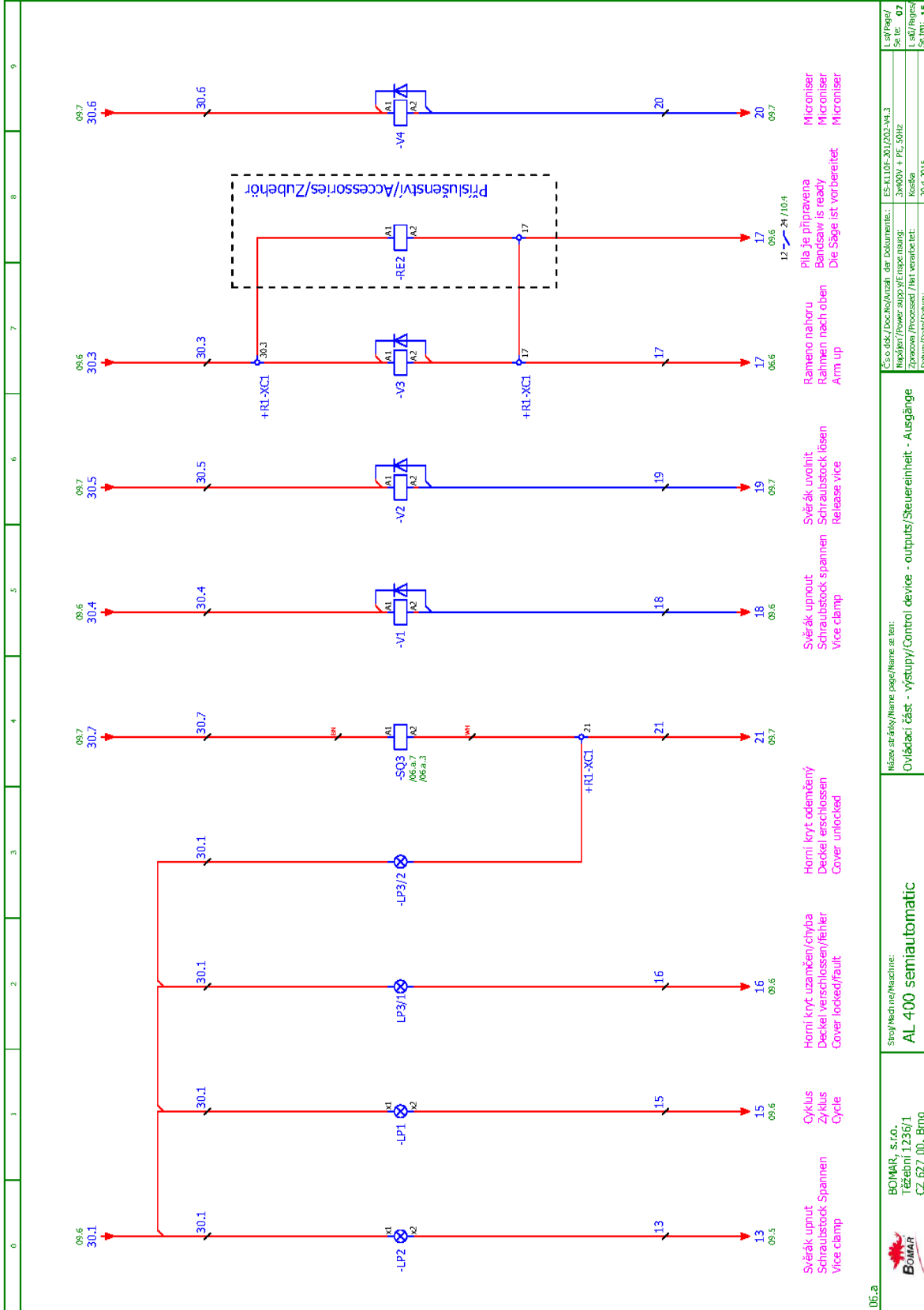

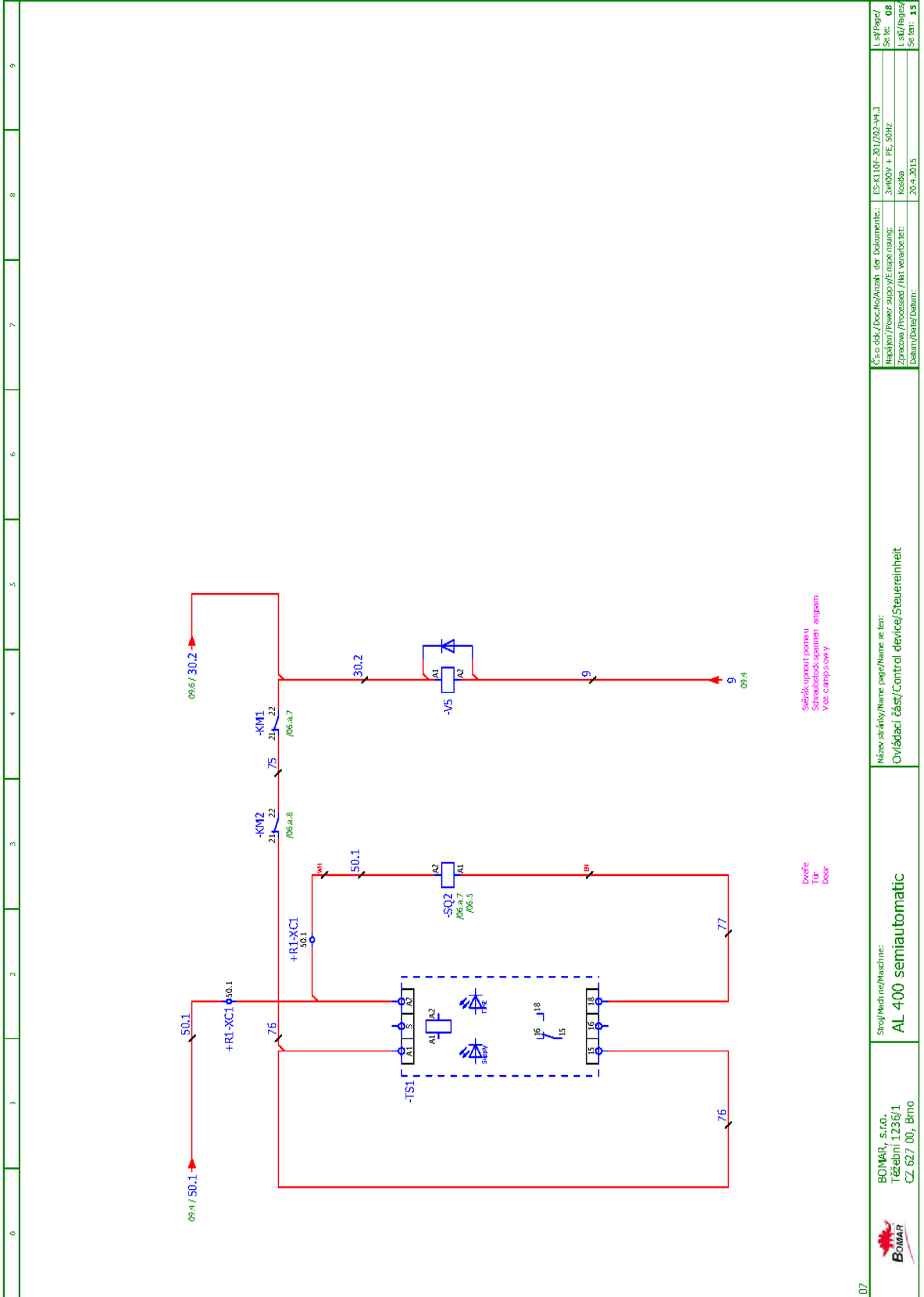

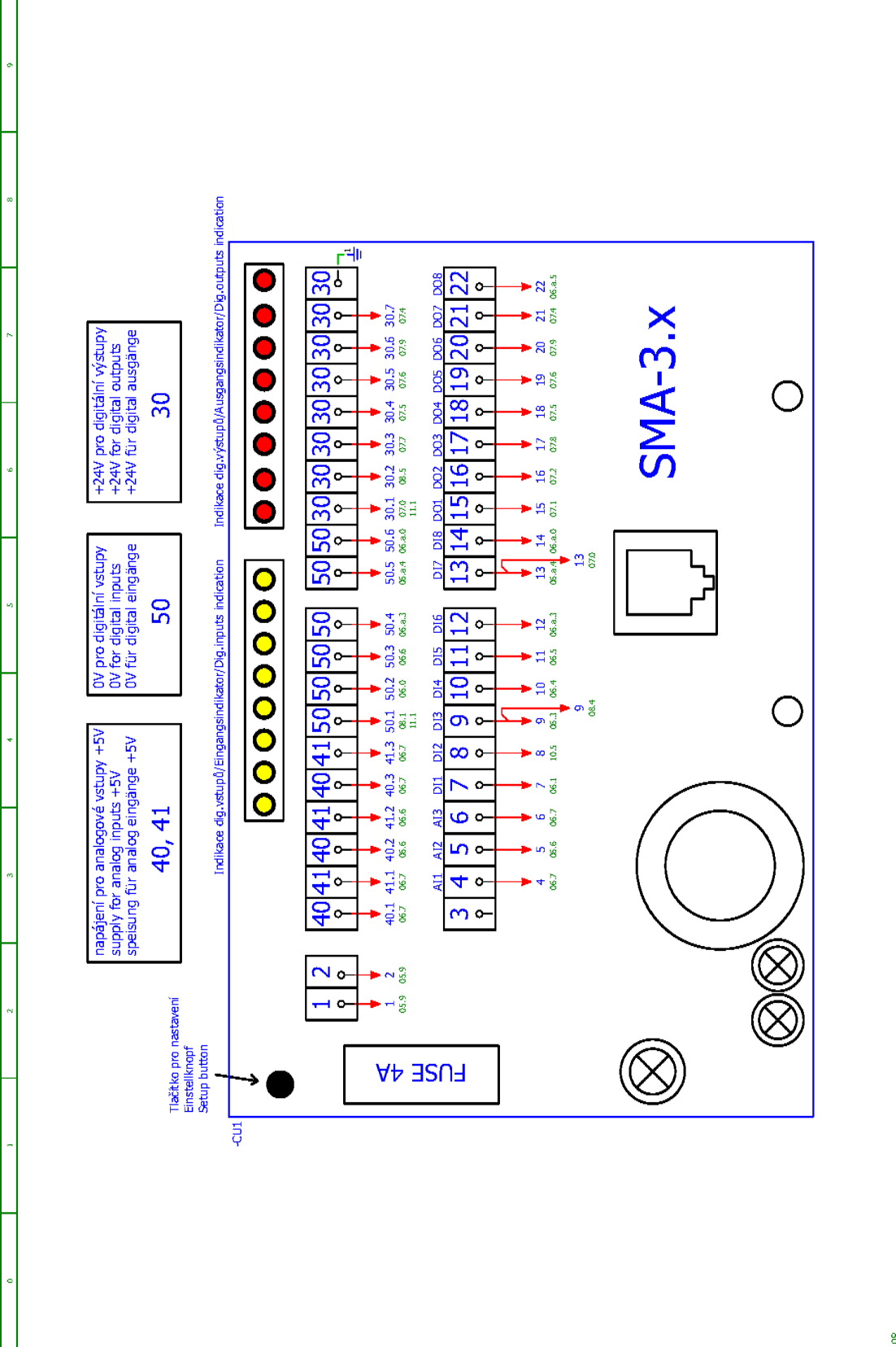

 BOMAR, s.r.o. Třeborní 1236/1 CZ 627 00, Brno	Společnost/Maschine: AL 400 semiautomatic	Název stránky/Name page/Name seiten: Řídicí systém/Control system/Steuer system	Číslo dok./Doc.No./Anzahl der Dokumenten.: ES-K110F-201/202-V4-3 Revize/Version: 09 Název/Name supply/Erspeisung: 3xM00V + PF, 50Hz Zpracov./Processed /Mit verarbeitet: Kosiška Datum/Dating/batum.: 29.4.2015
08			

Schemata
Schemata
Schematics

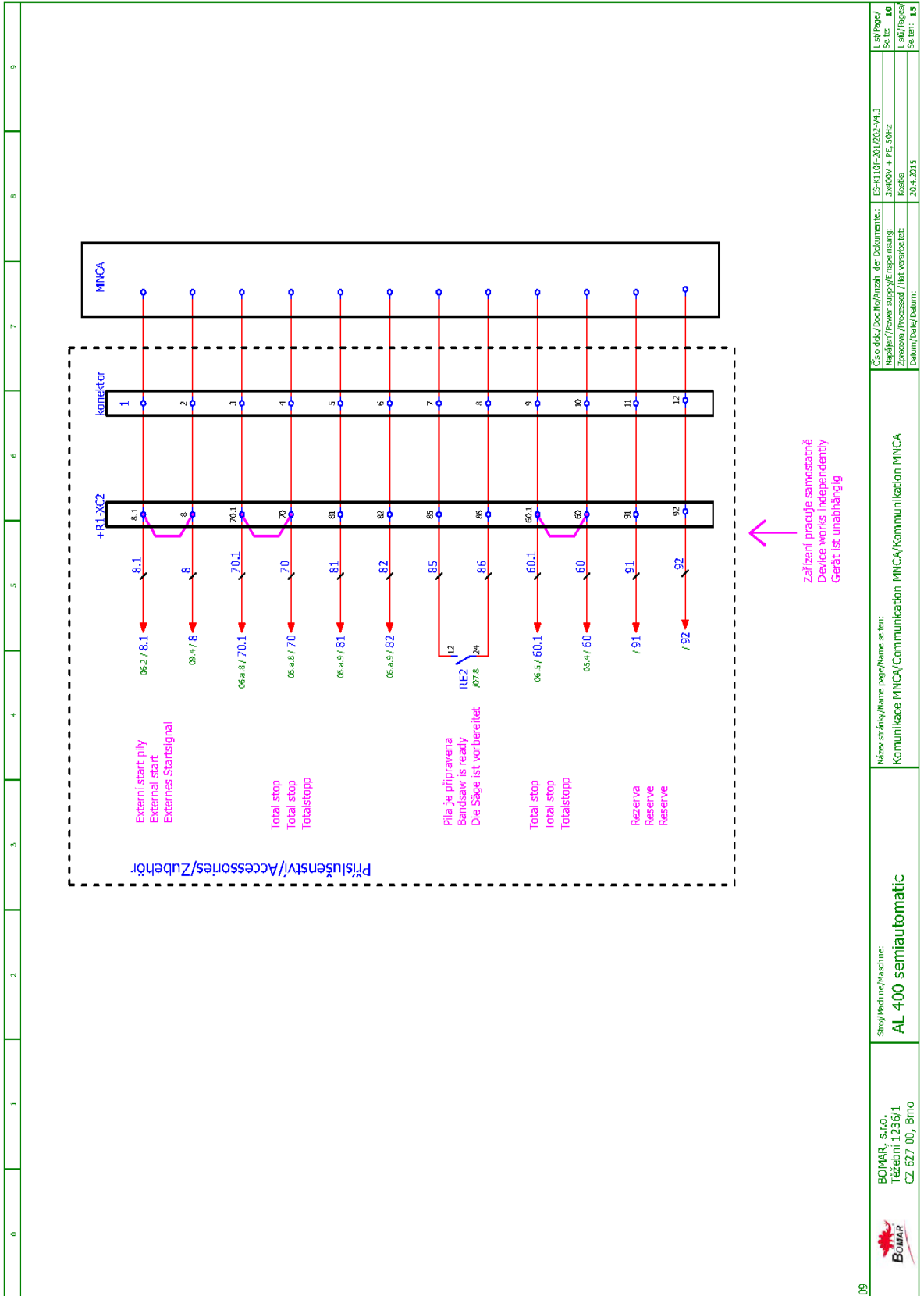

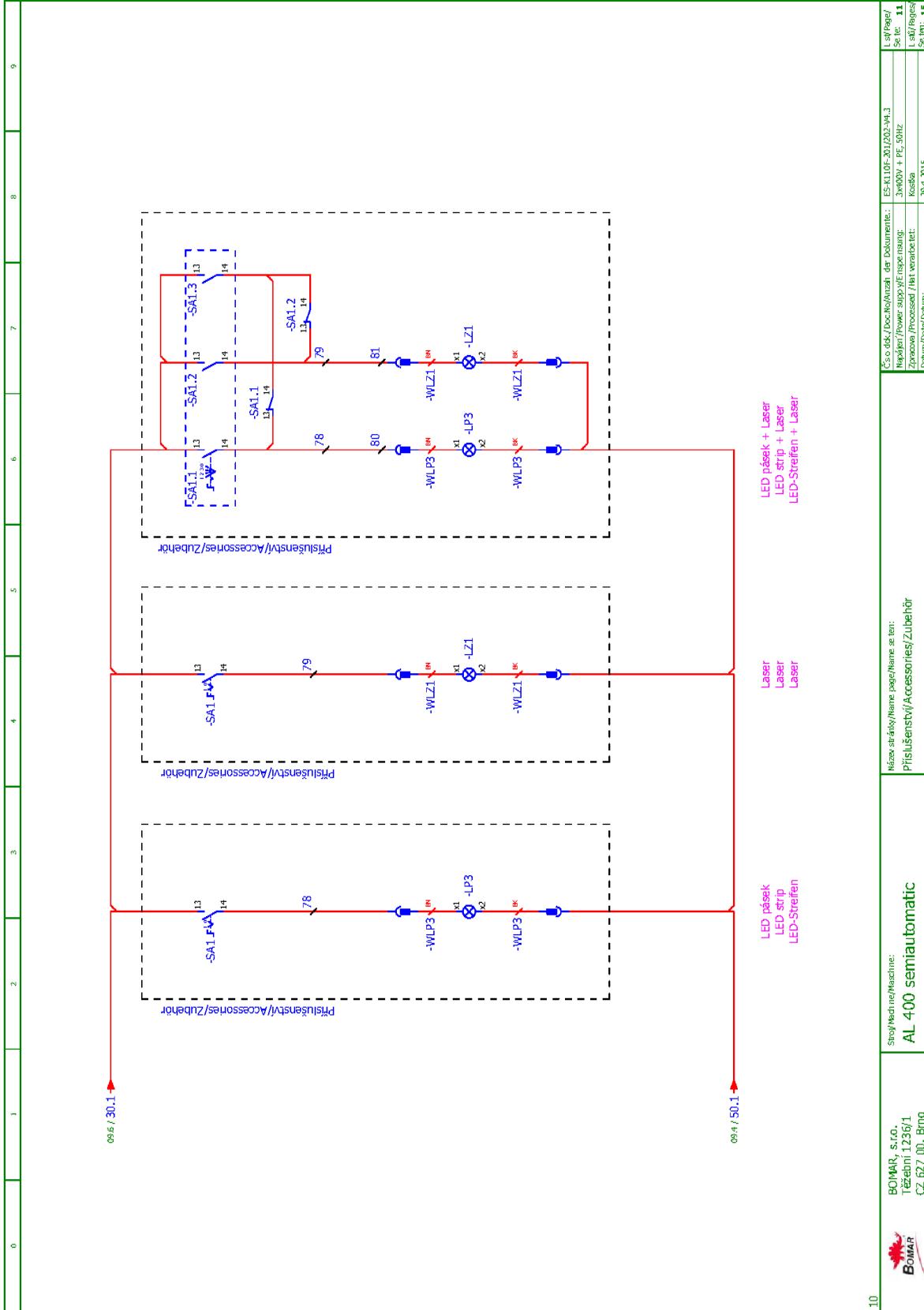





BOMAR, s.r.o. Třebetín 1236/1 CZ 627 00, Brno	Společnost/Maschine: AL 400 semiautomatic	Název schéma/Name page/Name seiten: Přislusenství/Accessories/Zubehör	ES o.d.k./DocNo/Anzahl der Dokumenten: ES-K10F-201/02-V4.3	L. s. / Page / Str. Nr. / 11
	Datum/Datum: 29.4.2015	Zpracov / Processed / Mit verarbeitet: Kosska	Repáží / Power supply/Ersatzteil: 3x100V + PE, 50Hz	L. s. / Page / Str. Nr. / 15

Schemata
Schemata
Schematics

5.2. Elektrické schéma /Elektroschema /Wiring diagrams
s frekv. měničem / mit Frequenzumrichter / without
frequency convertor 3×230 V+PE,50Hz

0	1	2	3	4	5	6	7	8	9						
 <p>BOMAR, s.r.o. Těžební 1236/1 627 00 Brno Czech republic</p> <p>AL 400 semiautomatic ES-K110F-203-V4.3 Wiring diagram 3x230V + PE, 50Hz</p>															
<table border="1" style="width: 100%; border-collapse: collapse;"> <tr> <td style="width: 15%; text-align: center;">  </td> <td style="width: 25%;"> BOMAR, s.r.o. Těžební 1236/1 CZ 627 00, Brno </td> <td style="width: 25%;"> Společnost/Name: AL 400 semiautomatic </td> <td style="width: 25%;"> Název stránky/Name page/Name seiten: Úvodní strana/ Start page/ Startseite </td> <td style="width: 15%;"> Číslo dok./Doc.No/Anzahl der Dokumente: ES-K110F-203-V4.3 Napájení/Power supply/Einspeisung: 3x230V + PE, 50Hz Koska Datum/Dating/datum: 20.4.2015 </td> <td style="width: 10%;"> List/Page/ Seite: 00 List/Reihen/ Seite: 15 </td> </tr> </table>											BOMAR , s.r.o. Těžební 1236/1 CZ 627 00, Brno	Společnost/Name: AL 400 semiautomatic	Název stránky/Name page/Name seiten: Úvodní strana/ Start page/ Startseite	Číslo dok./Doc.No/Anzahl der Dokumente: ES-K110F-203-V4.3 Napájení/Power supply/Einspeisung: 3x230V + PE, 50Hz Koska Datum/Dating/datum: 20.4.2015	List/Page/ Seite: 00 List/Reihen/ Seite: 15
	BOMAR , s.r.o. Těžební 1236/1 CZ 627 00, Brno	Společnost/Name: AL 400 semiautomatic	Název stránky/Name page/Name seiten: Úvodní strana/ Start page/ Startseite	Číslo dok./Doc.No/Anzahl der Dokumente: ES-K110F-203-V4.3 Napájení/Power supply/Einspeisung: 3x230V + PE, 50Hz Koska Datum/Dating/datum: 20.4.2015	List/Page/ Seite: 00 List/Reihen/ Seite: 15										

Page	Page name	Date
00	Úvodní strana/ Start page/ Startseite	20.4.2015
01	Obsah/ Table of contents/ Inhaltsverzeichnis	20.4.2015
02	I/O řídicí systém / I/O Control station / I/O Steuerung	25.6.2014
03	Rozmístění prvků v rozvaděči/Element lay-out in the distributor/Platzierung der Geräte im Schaltschrank	25.6.2014
03.a	Ovládací panel/Control Panel/Steuerpult	25.6.2014
04	Kusovník artiklů/ Parts list/ Artikelstückliste	20.4.2015
04.a	Kusovník artiklů/ Parts list/ Artikelstückliste	20.4.2015
05	Silová část/Power part/Feld partie	25.6.2014
06	Ovládací část - vstupy/Control device - inputs/Steuerinheit - Eingänge	20.4.2015
06.a	Ovládací část - vstupy/Control device - inputs/Steuerinheit - Eingänge	20.4.2015
07	Ovládací část - výstupy/Control device - outputs/Steuerinheit - Ausgänge	20.4.2015
08	Ovládací část/Control device/Steuerinheit	20.4.2015
09	Řídicí systém/Control system/Steueresystem	20.4.2015
10	Komunikace MMCA/Communication MMCA/Kommunikation MMCA	25.6.2014
11	Příslušenství/Accessories/Zubehör	20.4.2015

00	 BOMAR, s.r.o. Třebetín 1236/1 CZ 627 00, Brno	Společnost/Name: AL 400 semiautomatic	Název stránky/Name page/Name seite: Obsah/ Table of contents/ Inhaltsverzeichnis	Číslo dok./Doc.No./Anzahl der Dokumente: ES-K10F-203-V4.3	L. st./Page/ Se. nr. L. st./Reihe/ Se. nr.: 01
				Repakce/Power supply/Energieanlage: Zpracováno/Processed / Mit verarbeitet: datum/Datum: Kosska 20.4.2015	L. st./Page/ Se. nr.: 15

0	1	2	3	4	5	6	7	8	9
---	---	---	---	---	---	---	---	---	---

AL 400 semiautomatic

I/O	CZE	ENG	DE
AI 1	Nastavení výšky ramene	High position setup	Einstellung höherahmen
AI 2	Snímač výšky ramene	High position sensor	Sensor höherahmen
AI 3	Nastavení microniseru	Microniser adjust	Einstellung Microniser
DI 1	Stop motor/cyklus	Stop motor/cycle	Stop motor/zyklus
DI 2	Start motor/cyklus	Start motor/cycle	Start motor/zyklus
DI 3	Světlák upnout	Clamp vice	Schraubstock spannen
DI 4	Světlák uvolnit	Release vice	Schraubstock lösen
DI 5	Total stop	Total stop	Totalstopp
DI 6	Horní kryt	Upper cover	Oberer Deckel
DI 7	Tlakový spínač	Pressure switch	Druckschalter
DI 8	Rameno dole	Arm is down	Rahmen is oben
DO 1	Cyklus	Cycle	Zyklus
DO 2	Horní kryt uzamčen/dyba	Cover locked/fault	Deckel verschlossen/fehler
DO 3	Rameno nahoru	Arm up	Rahmen nach oben
DO 4	Světlák upnout	Vice clamp	Schraubstock spannen
DO 5	Světlák uvolnit	Release vice	Schraubstock lösen
DO 6	Microniser	Microniser	Microniser
DO 7	Horní kryt odemčený	Cover unlocked	Deckel erschlossen
DO 8	Total stop	Total stop	Totalstopp

HW	
FW	

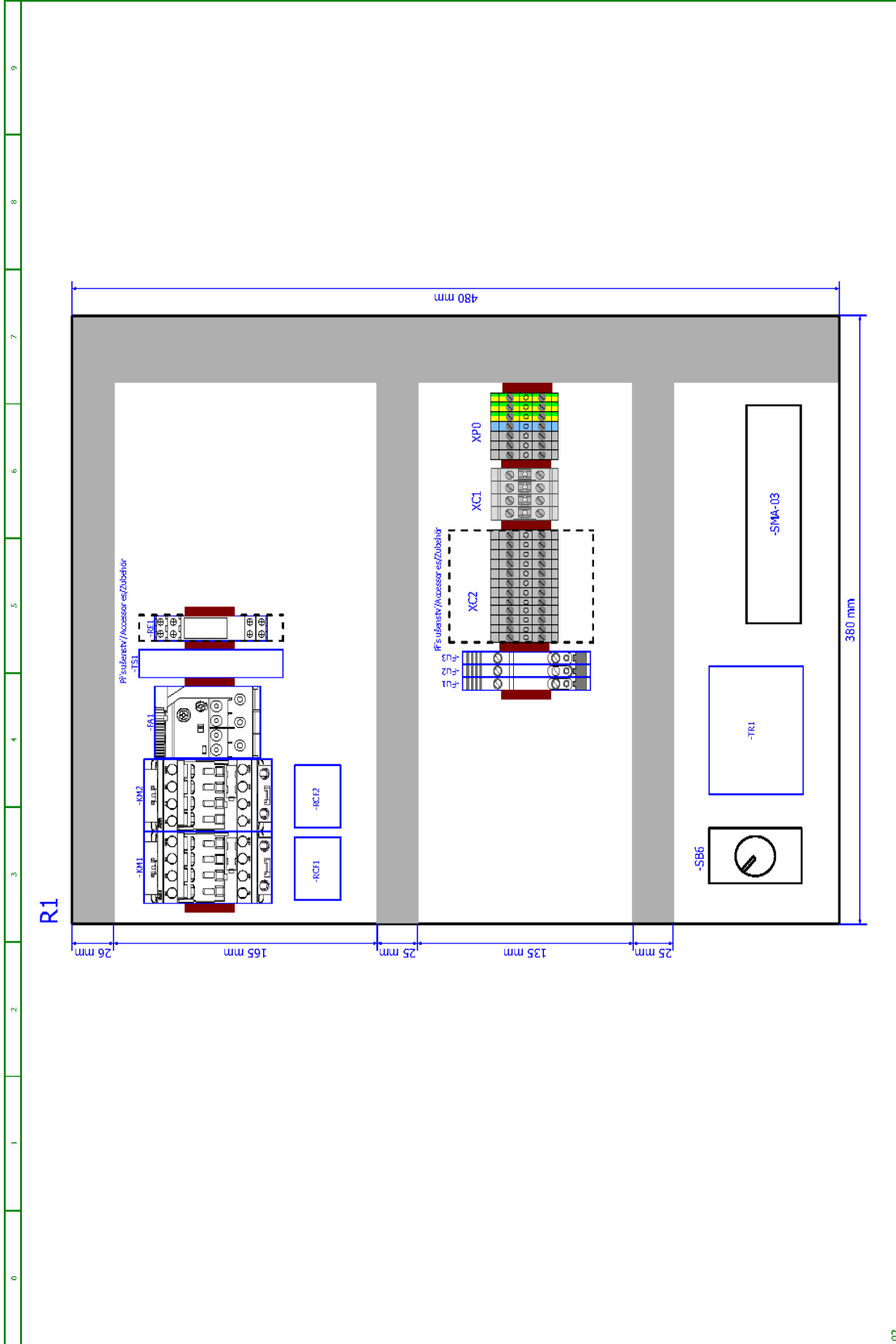

02	BOMAR, s.r.o. Třebetín 1236/1 CZ 627 00, Brno	Spol/Mech/Ver/Maschine: AL 400 semiautomatic	Název stránky/Name page/Name se stran: Rozmístění prvků v rozvaděči/Element layout in the distributor/Platzierung der Geräte im Schaltschrank	Číslo dok./Doc.No./Anzahl der Dokumenten: ES-K100-203-V4.3	LSH Page/ Seite: L. 03/Reise/
				Regeljen/Power supply/Einspeisung: 3x230V + PE, 50Hz	
				Prüfung/Processed/Her. verarbeitet: 23.6.2014	Seite: L. 03/Reise/
				Datum/Dang/batum:	Seite: L. 15

Schemata
Schemata
Schematics

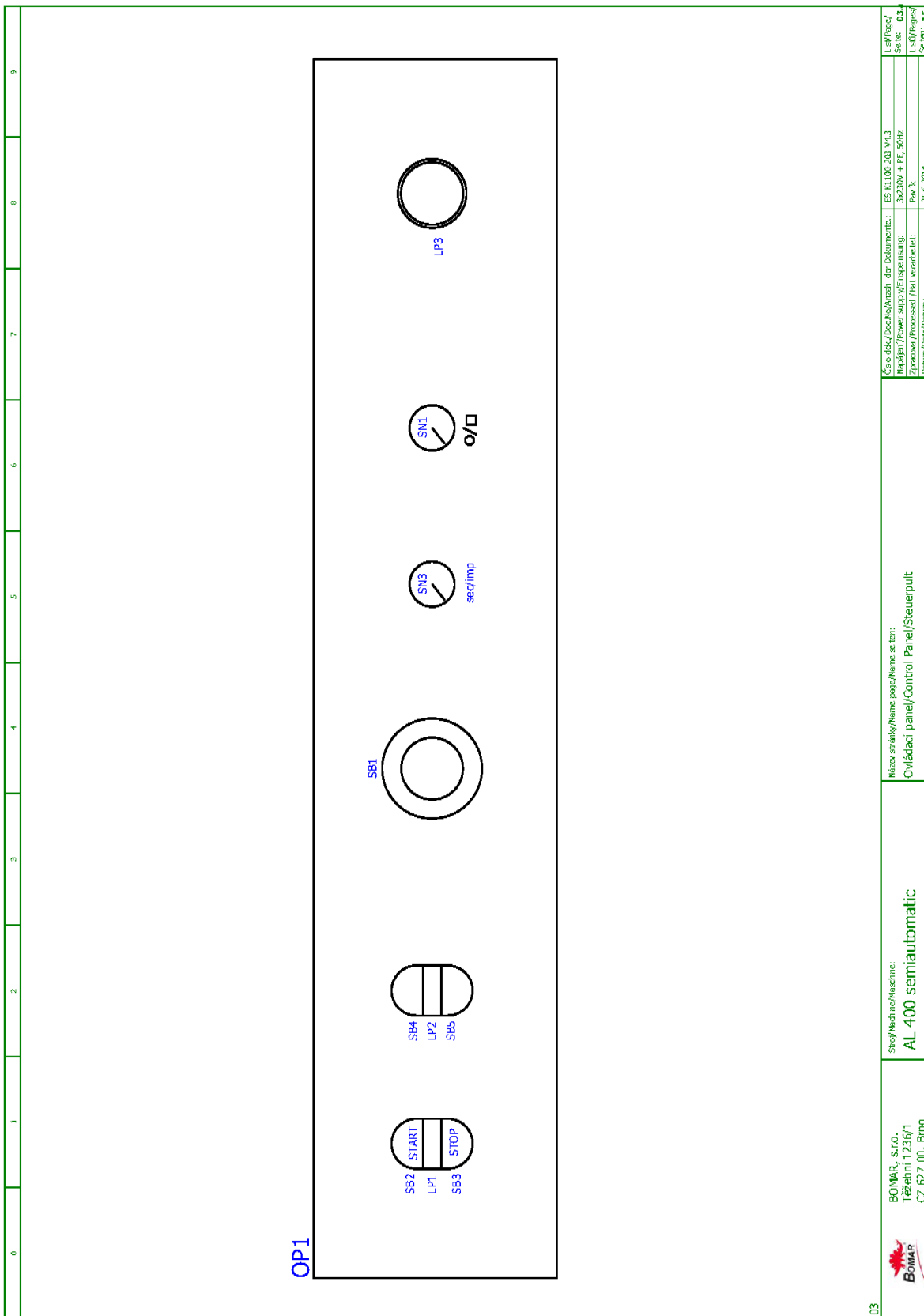

0	1	2	3	4	5	6	7	8	9
Parts list									
Device identification	Device description	Type number	Manufacturer	Part number	Quantity	Location (page,column)			
-CU1	Control unit SMA 3.x	SMA 3.X	BOMAR s.r.o.	91.995.222	1	/09.1			
-FM1	Frequency converter - 3.7kW, 3x230VAC	VFD037E23A + KPE-LE02	DELTA ELECTRONICS, INC.	91.012.090	1	/05.1			
-FU1	Fuse terminal	WK47H5ISU	WIELAND	91.251.102	1	/05.6			
-FU1	Tube fuse - 1A/250V, slow, 5x20	T1A/250V	ESKA	91.230.031	1	/05.6			
-FU2	Fuse terminal	WK47H5ISU	WIELAND	91.251.102	1	/05.6			
-FU2	Tube fuse - 1A/250V, slow, 5x20	T1A/250V	ESKA	91.230.031	1	/05.6			
-FU3	Tube fuse - 4A/250V, slow, 5x20	T4A/250V	ESKA	91.230.015	1	/05.8			
-FU3	Fuse terminal	WK47H5ISU	WIELAND	91.251.102	1	/05.8			
-KM1	Contact - 5.5kW/400V, 3P	AF12-30-01-11	ABB	91.040.051	1	/06.a.7			
-KM2	Contact - 5.5kW/400V, 3P	AF12-30-01-11	ABB	91.040.051	1	/06.a.8			
-LP1	The head backlit buttons white	M22-DL-W	EATON	91.060.038	1	/07.1			
-LP2	White light for Eaton adapter	M22-LED-W	EATON	91.061.034	1	/07.0			
-LP3/1	LED red and green common ground 24V DC	HIS-95 G/R 24V DC	ELECO	91.060.069	1	/07.2			
-PA1	Fuse disconnecter E-90 - 3P	E 93/32	ABB	91.241.014	1	/05.2			
-PA1	Tube fuse - 25A, 10x38, fast	PV10 25A, gG	OEZ	91.230.021	3	/05.2			
-QS1	Disconnecter - 3P, 25A	OT25FT3	ABB	91.170.016	1	/05.1			
-QS1	Handle switch - black	OHBS3RH	ABB	91.180.016	1	/05.1			
-RCF0	RFC-filter - 5.5 kW, 3x400V/230V, 25A	ATV31/5.5KW	Ing. Miroslav Vřětek	91.041.027	1	/05.1			
-RCF1	Efferent RFC filter	FBOPRL624	Ing. Miroslav Vřětek	91.041.015	1	/05.1			
-RCF2	Efferent RFC filter	FBOPRL624	Ing. Miroslav Vřětek	91.041.015	1	/05.1			
-RE1	Plug-in relay	CR-P024DC2	ABB	91.051.049	1	/06.a.5			
-RE1	Relay socket	CR-PSS	ABB	91.051.048	1	/06.a.5			
-RE2	Plug-in relay	CR-P024DC2	ABB	91.051.049	1	/07.8			
-RE2	Relay socket	CR-PSS	ABB	91.051.048	1	/07.8			
-RP1	Potentiometer 4k7	TP195 4k7/M20A	GES-ELECTRONICS, a.s.	91.283.015	1	/05.5			
-RP1	Head of potentiometer 24mm	S8877 BLK	GES-ELECTRONICS, a.s.	91.060.063	1	/05.5			
-RP1	Fastconnect clamp	WAGO 224-112	WAGO	91.250.009	3	/05.5			
-SB1	Emergency-stop mushroom push - button + 3xNC	YW1B-V4E02R	IDEC	91.060.084	1	/06.5			

The manufacturer reserves right to use an equivalent replacement device.

03.a	BOMAR, s.r.o. Třebetín 1236/1 CZ 627 00, Brno	Spotřeba/Machine: AL 400 semiautomatic	Název stránky/Name page/Name seiten: Kusovník artiklů/ Parts list/ Artikelstückliste	Číslo dok./DocNo./Anzahl der Dokumenten.: ES-K10F-203-V4-3	Let Page/ Seite: L. 04
				Typ/Kategorie/Power supply/Energieversorgung: 3x230V + PE, 50Hz	Seite: L. 04
				Zpracováno/Processed / Mit verarbeitet: Koska	Seite: L. 04/Revised
				Datum/Dating/datum: 20.4.2015	Seiten: 15

0	1	2	3	4	5	6	7	8	9
Parts list									
Device identification	Device description	Type number	Manufacturer	Part number	Quantity	Location (page,column)			
-SB2	Double button head white/black start/stop	M22-DDL-WS-GB1/GB0	EATON	91.060.034	1	/06.2			
-SB2	Attaching adapter + 1NO	M22-AK10	EATON	91.061.021	1	/06.2			
-SB3	NO contact for Eaton adapter	M22-K10	EATON	91.061.022	1	/06.1			
-SB4	Double button head white/black, arrow close/open	M22-DDL-WS-*	EATON	91.060.055	1	/06.3			
-SB4	Attaching adapter + 1NO	M22-AK10	EATON	91.061.021	1	/06.3			
-SB5	NO contact for Eaton adapter	M22-K10	EATON	91.061.022	1	/06.4			
-SB6/1	Attaching adapter + 1NC	M22-AK01	EATON	91.061.020	1	/06.a.5			
-SB6/1	Switch 2 positions	M22 - WKV	EATON	91.060.037	2	/06.a.5			
-SB6/2	NC contact for Eaton adapter	M22-K01	EATON	91.061.024	1	/06.a.8			
-SB6/3	NO contact for Eaton adapter	M22-K10	EATON	91.061.022	1	/06.6			
-SW1	Potentiometer 4k7	TP195 4k7/N20A	GES-ELECTRONICS, a.s.	91.283.015	1	/06.8			
-SW1	Head of potentiometer 24mm	S8877 BLK	GES-ELECTRONICS, a.s.	91.060.063	1	/06.8			
-SW1	Fastconnect clamp	WAGO 224-112	WAGO	91.250.009	3	/06.8			
-SW2	Position measuring	DH-RAIM	Bomar	262.012	1	/06.7			
-SW3	Potentiometer 4k7	TP195 4k7/N20A	GES-ELECTRONICS, a.s.	91.283.015	1	/06.8			
-SW3	Head of potentiometer 24mm	S8877 BLK	GES-ELECTRONICS, a.s.	91.060.063	1	/06.8			
-SW3	Fastconnect clamp	WAGO 224-112	WAGO	91.250.009	3	/06.8			
-SQ1	Head	ZCE10	TELEMECANIQUE	91.061.201	1	/06.a.0			
-SQ1	The switch body	ZCD31	TELEMECANIQUE	91.061.202	1	/06.a.0			
-SQ1	Cable gland	ZCDEG11	TELEMECANIQUE	91.061.203	1	/06.a.0			
-SQ2	Safety Limit Switch with 24V coil	D4NL-4HFA-B	OMRON	91.173.040	1	/08.3			
-SQ3	Safety Limit Switch with 24V coil	D4NL-4HFA-B	OMRON	91.173.040	1	/07.4			
-TR1	Toroidal transformer - 400V / 230V / 20V 4,5A 90VA	400V/230V/20V 4,5A 90VA	KARBAN s.r.o.	91.060.023	1	/05.7			
-TS1	Multifunction time relay - 12-240V, 10 functions	CRM-91H/UNI	ELKO	91.061.027	1	/08.1			

The manufacturer reserves right to use an equivalent replacement device.

BOMAR, s.r.o. Těžeň 1236/1 CZ 627 00, Brno		Step/Mechanism: AL 400 semiautomatic		Název stroje/Mechanismus: Kusunovnik artiklů/ Parts list/ Artikelstückliste		ES-K10F-203-V4.3 3x230V + PE, 50Hz Kosař 20.4.2015		Lst/ Page/ Se. te. 04 Lst/ Replac/ Se. te. 15	
--	--	--	--	--	--	---	--	--	--

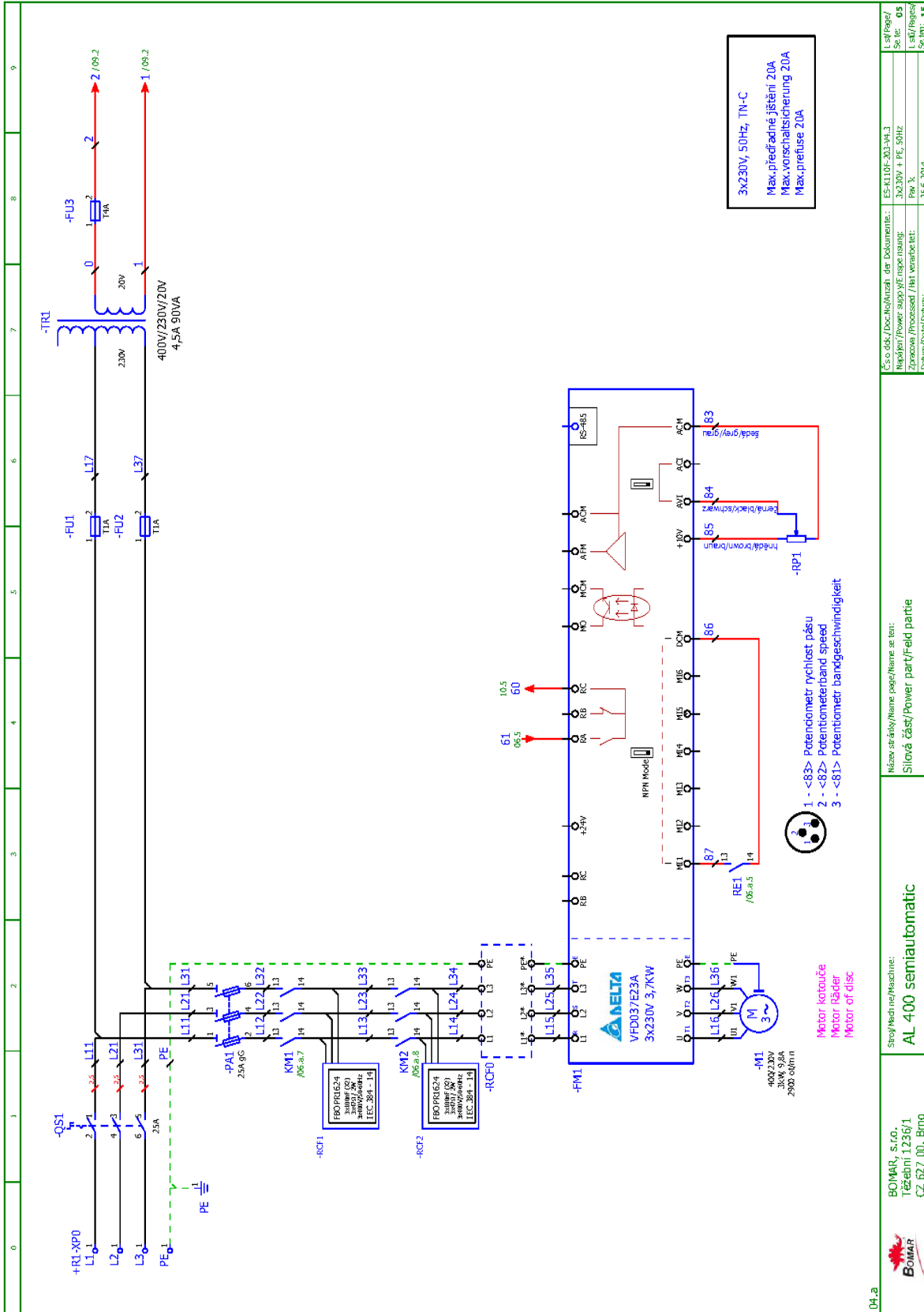

3x230V, 50Hz, TN-C
 Max. předřadné jističní 20A
 Max. vorschaltssicherung 20A
 Max. prefuse 20A

- 1 - <83> Potentiometer rychlost pásu
- 2 - <82> Potentiometer band speed
- 3 - <81> Potentiometer bandgeschwindigkeit

Motor katódice
 Motor läder
 Motor of disc

04_a	Společnost/Machine: BOMAR, s.r.o. Třebonín 1236/1 CZ 627 00, Břno	Název stroje/Name page/Name se min: AL 400 semiautomatic	Číslo dok./DocNo/Anzahl der Dokumenten: ES-K10F-203-V4-3	Liš/Page/ Seite: 05
			Regulátor/Power supply/Energieanlage: 3x230V + PE, 50Hz	
			Prac. k./ Datum/Dating/batum:	Liš/Page/ Seite: 15

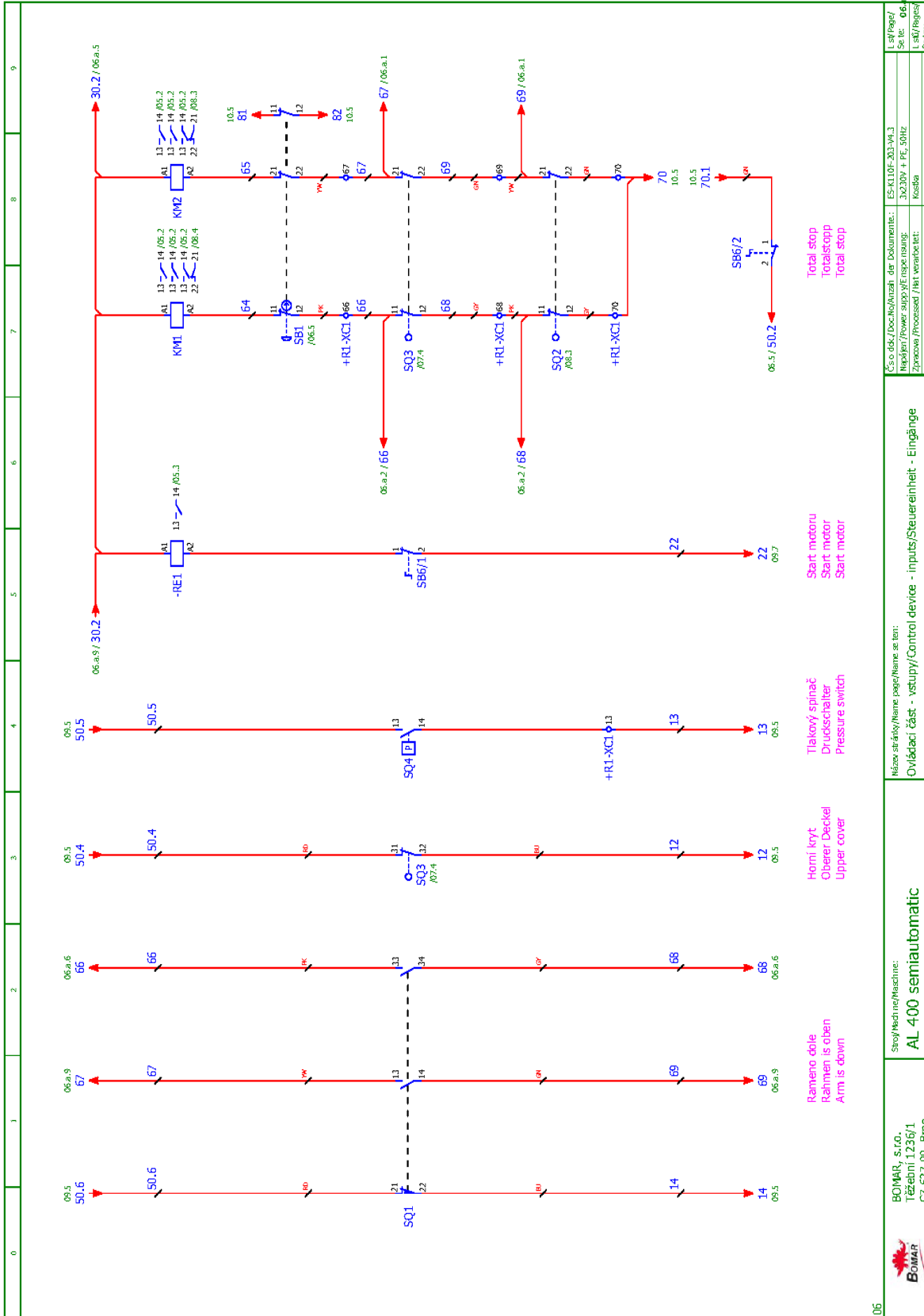

Rameno dle
Rahmen is oben
Arm is down

Horní kryt
Oberer Deckel
Upper cover

Tlakový spínač
Druckschalter
Pressure switch

Start motoru
Start motor
Start motor

Total stop
Totalstopp
Total stop

06



BOMAR, s.r.o.
Třebetín 1236/1
CZ 627 00, Brno

Stroj/Mechine/Maschine:
AL 400 semiautomatic

Název stroje/Name page/Name se ten:
Ovládací část - vstupní/Control device - inputs/Steuerinheit - Eingänge

CS o.dok./DocNo/Anzahl der Dokumenten:	ES-K10F-203-V4.3	L. št/Paper/
Regulát./Power supply/E. speisung:	3x230V + PE, 50Hz	Se. tit. 06
Zpracová./Processed./Mit verarbeitet:	Koska	L. št/Regist.
Datum/Dating/Datum:	20.4.2015	Se. tent. 15

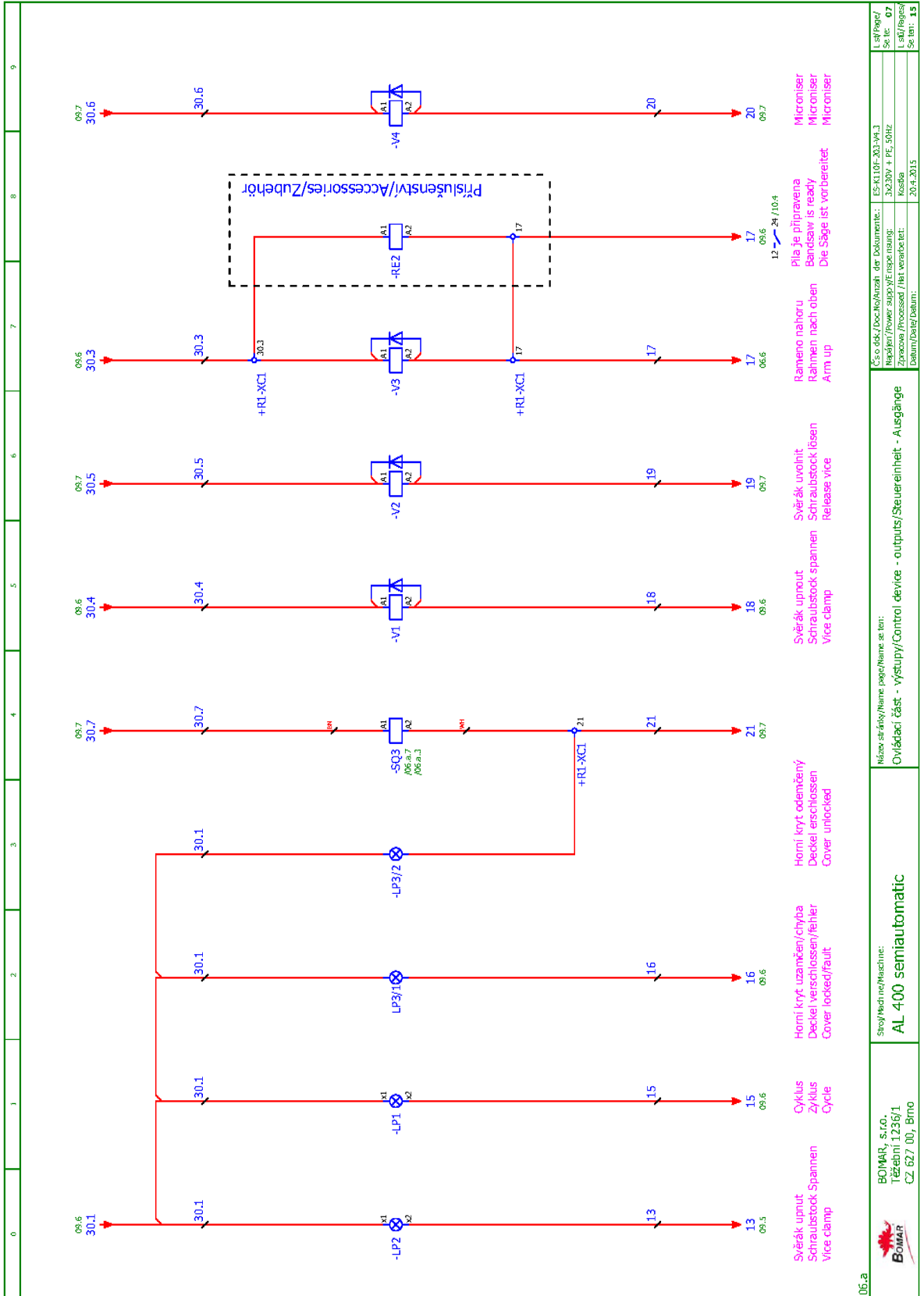

06.a

Název stroje/Machine: AL 400 semiautomatic Stroj/Mechine/Maschine: AL 400 semiautomatic		Název stroje/Name page/Name: Ovládací část - výstupy/Control device - outputs Ovládací část - výstupy/Control device - outputs	
BOMAR, s.r.o. Třebetín 1236/1 CZ 627 00, Brno		ES-K10F-203-V4.3 Napájení/Power supply/Erspeisung: 3x230V + PE, 50Hz Zpracováno/Processed/Her verarbeitet: Kosska Datum/Dating/datum: 20.4.2015	
L: 01/ Page/ Seite: 07 L: 04/ Reprint: 15		L: 01/ Page/ Seite: 07 L: 04/ Reprint: 15	

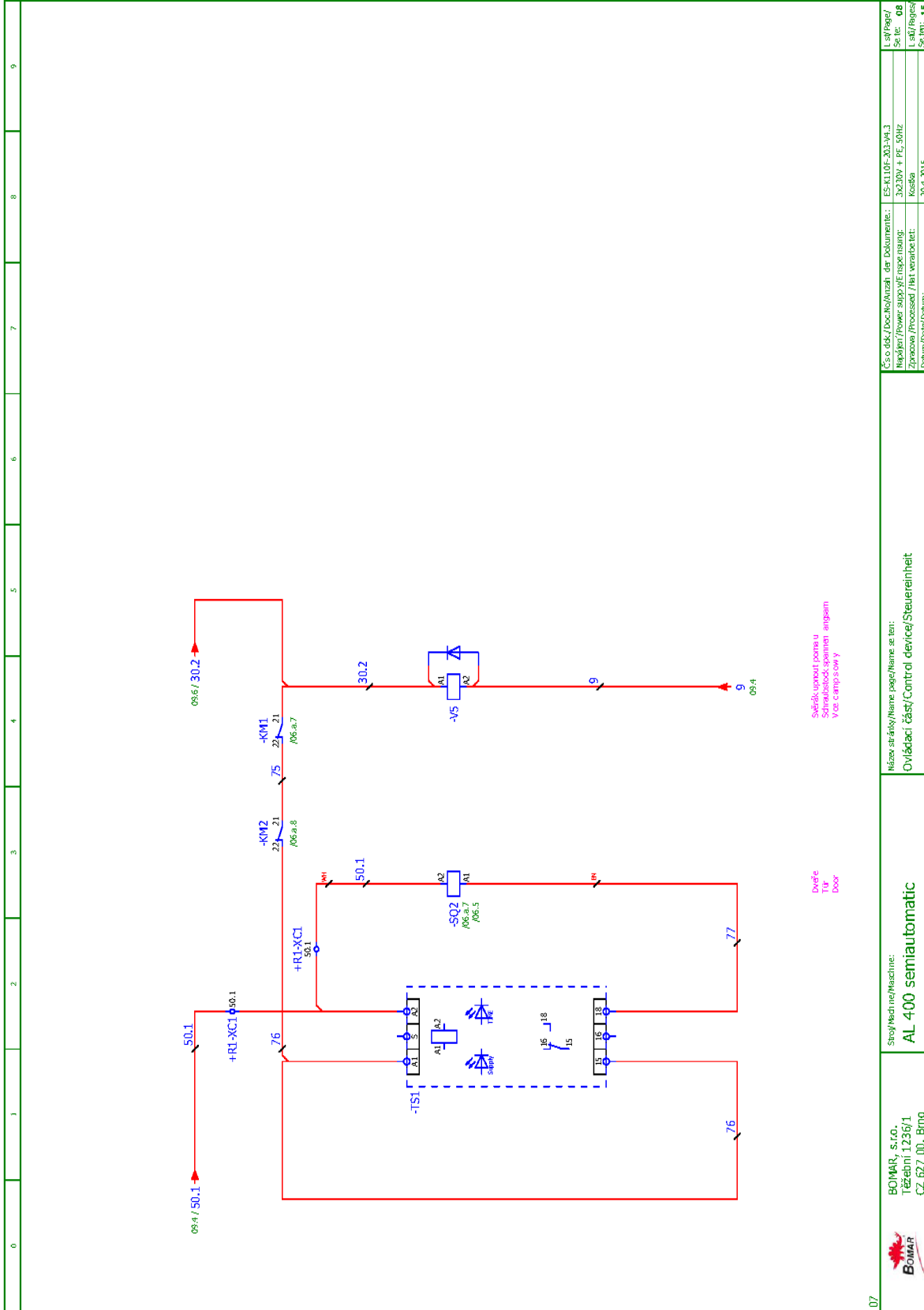

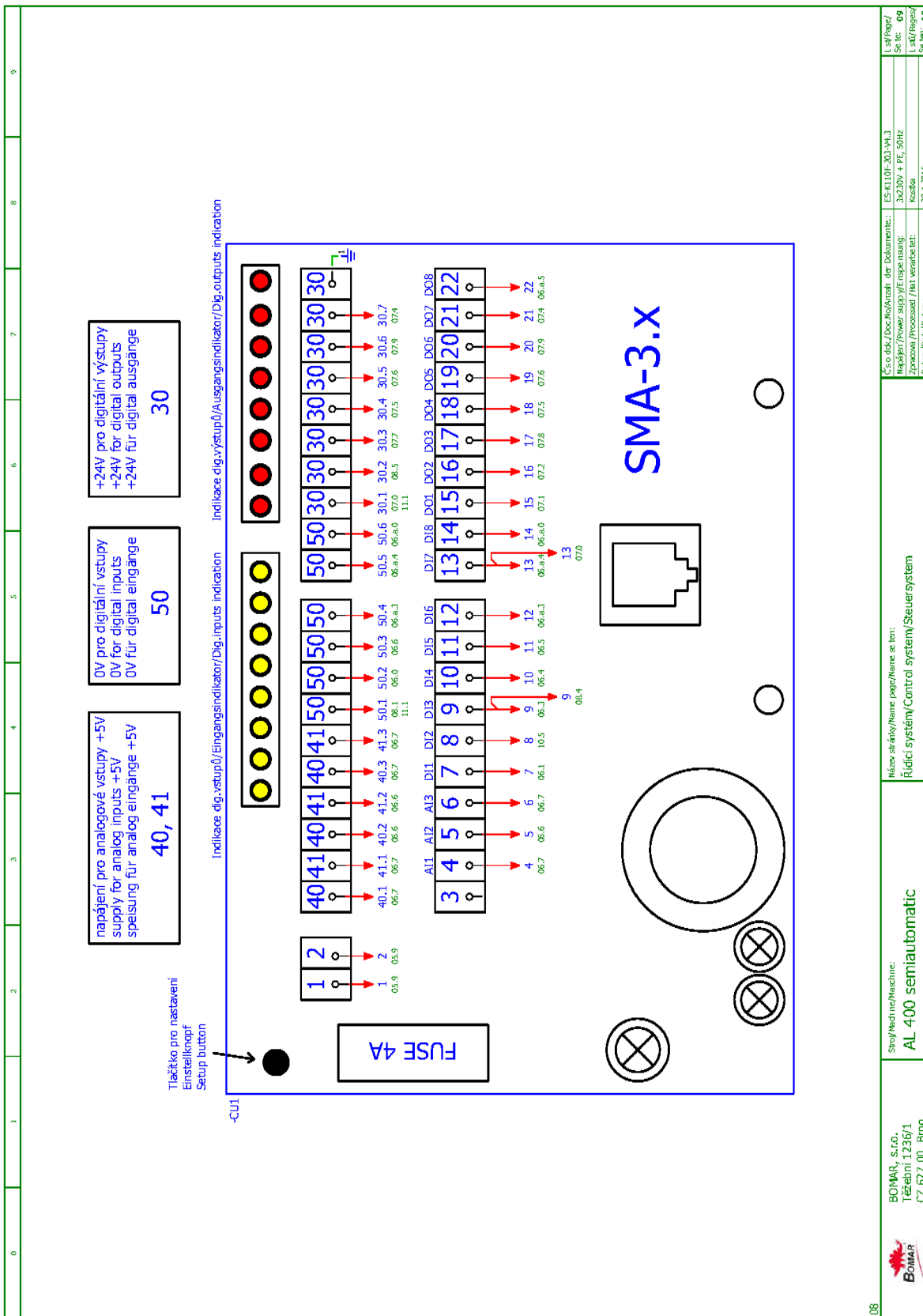

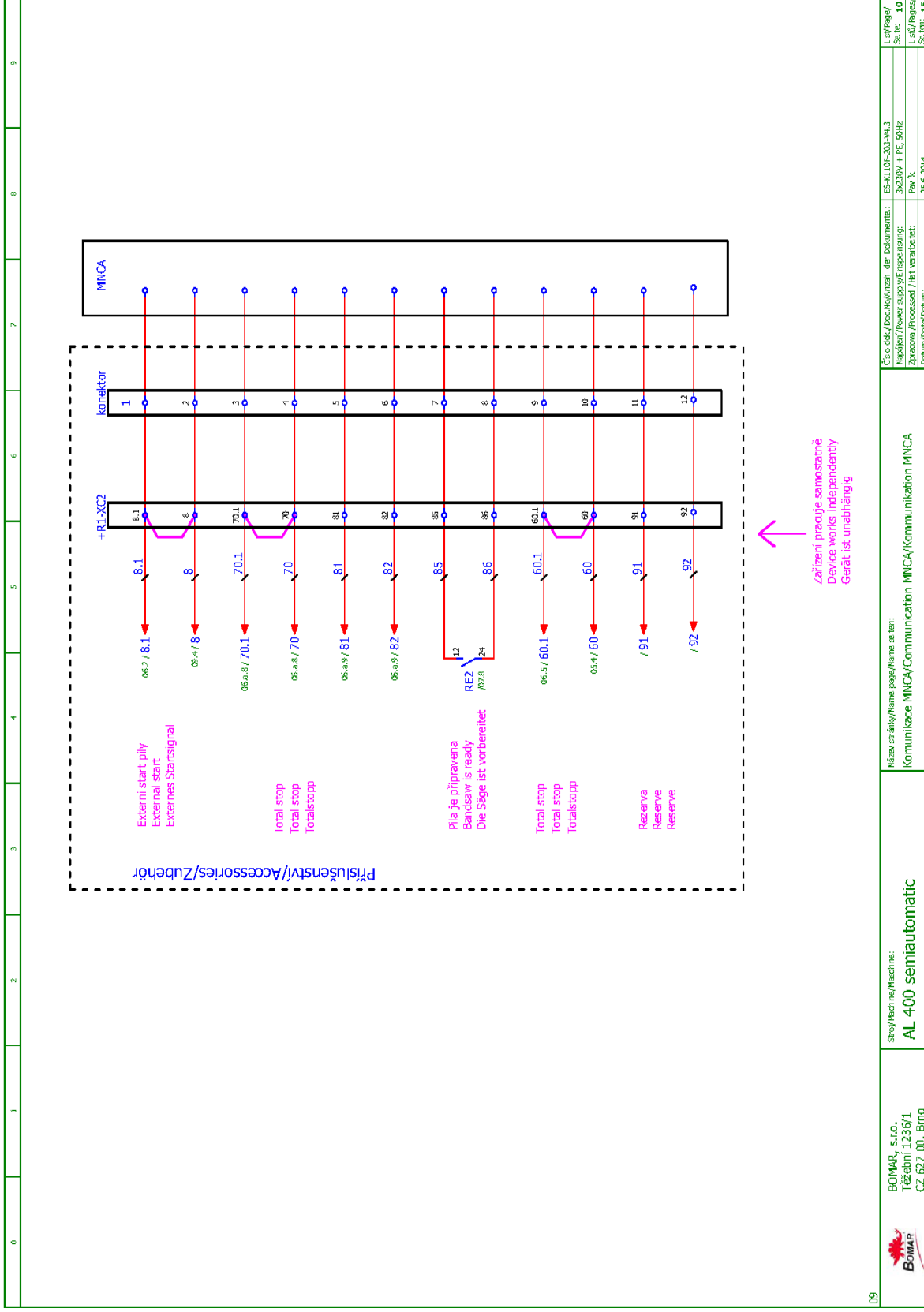

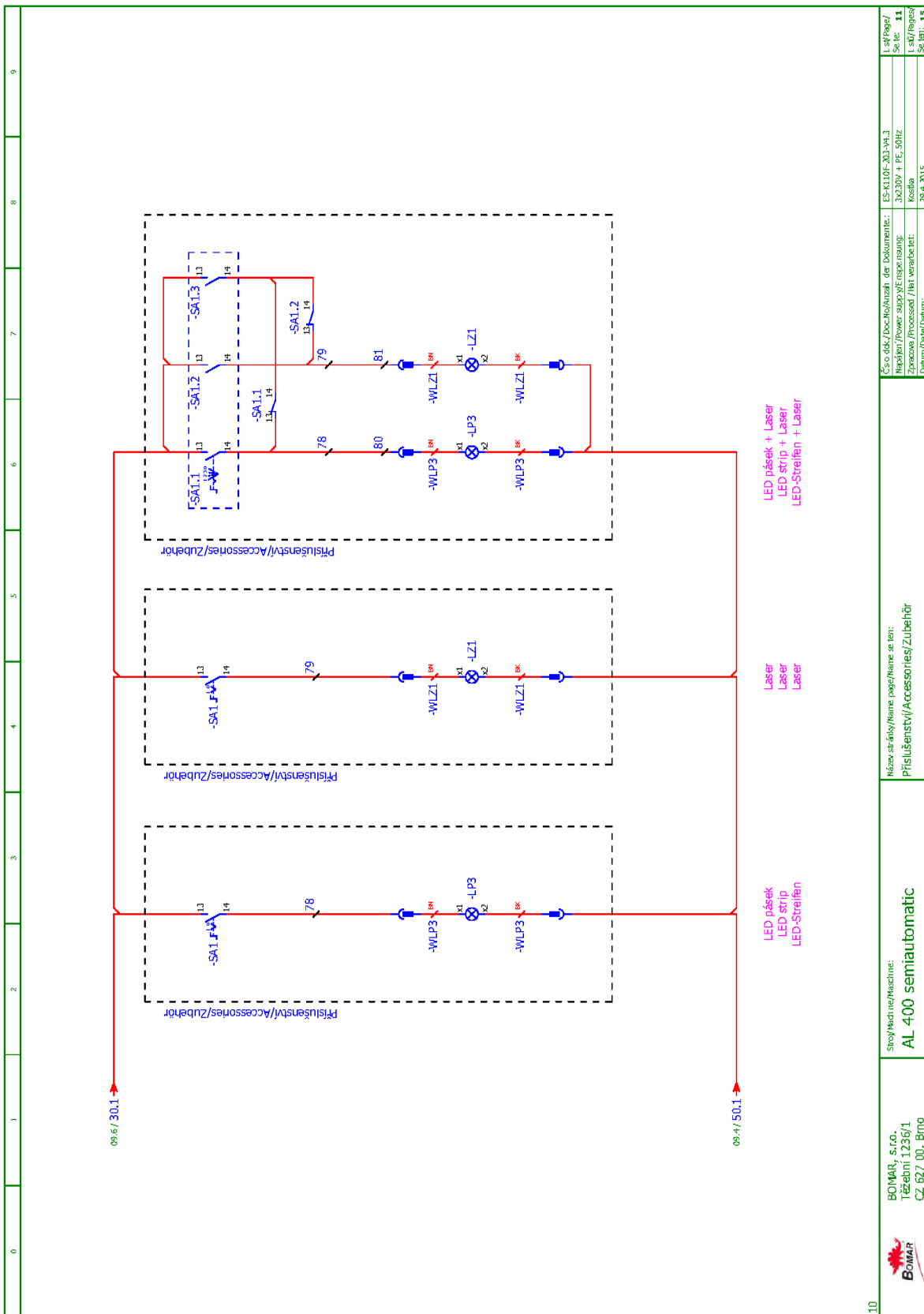



5.3. Elektroschema /Elektroschema /Wiring diagrams
 bez frekv. měniče / ohne Frequenzumrichter / without
 Frequency convertor, 3×400 V+PE,50Hz

0	1	2	3	4	5	6	7	8	9
		<p>Bomar, spol. s r.o. Těžební 1236/1 627 00 Brno Czech republic</p>		<h1>AL 400 semiautomatic</h1> <p>ES-K1100-201/202-V4.3</p> <h2>Wiring diagram</h2> <p>3x400V + PE, 50Hz</p>			<p>Číslo dok./Doc.No./Anzahl der Dokumente: ES-K1100-201/202-V4.3 Model/Power supply/Einspeisung: 3x400V + PE, 50Hz Zpracováno /Processed / Mit verarbeitet: Kosska Datum/Datum/datum: 20.4.2015</p>		
		Spis/Mechne/Maschine: AL 400 semiautomatic		Název stránky/Name page/Name seiten: Úvodní strana/ Start page/ Startseite			L. s. /Page/ Se. /: 00 L. s. / /Page/ Se. /: 15		

0	1	2	3	4	5	6	7	8	9
Obsah/ Table of contents/ Inhaltsverzeichnis									
Stránka/Page/Seite	Název stránky/Name page/Name Seite								Datum/Date/Datum
00	Úvodní strana/ Start page/ Startseite								25.6.2014
01	Obsah/ Table of contents/ Inhaltsverzeichnis								25.6.2014
02	I/O řídicí systém / I/O Control station / I/O Steuerung								25.6.2014
03	Rozmístění prvků v rozvaděči/Element lay-out in the distributor/Platzierung der Geräte im Schaltschrank								25.6.2014
03.a	Ovládací panel/Control Panel/Steuerpult								25.6.2014
04	Kusovník artiklů/ Parts list/ Artikelstückliste								25.6.2014
04.a	Kusovník artiklů/ Parts list/ Artikelstückliste								25.6.2014
05	Silová část/Power part/Feld partie								25.6.2014
06	Ovládací část - vstupy/Control device - inputs/Steuerinheit - Eingänge								25.6.2014
06.a	Ovládací část - vstupy/Control device - inputs/Steuerinheit - Eingänge								25.6.2014
07	Ovládací část - výstupy/Control device - outputs/Steuerinheit - Ausgänge								25.6.2014
08	Ovládací část/Control device/Steuerinheit								25.6.2014
09	Řídicí systémy/Control system/Steuersystem								25.6.2014
10	Komunikace MMCA/Communication MMCA/Kommunikation MMCA								25.6.2014

00



BOMAR, s.r.o.
 Třeborní 1236/1
 CZ 627 00, Brno

Stroj/Mechine/Maschine:
AL 400 semiautomatic

Název stránky/Name page/Name Seite:
 Obsah/ Table of contents/ Inhaltsverzeichnis

Číslo dok./Doc.No./Anzahl der Dokumente: ES-K100-03/02-V4.3
 Řepkový/Power supply/E.rspeisung: 3x400V + PE, 50Hz
 Zpracováno /Processed / Mit verarbeitet: Per. N.
 Datum/Date/ Datum: 25.6.2014

L. s. /Page/
 Se. /c. 01
 L. s. /Page/
 Se. /c. 15

AL 400 semiautomatic

HW
FW

I/O	CZE	ENG	DE
AI 1	Nastavení výšky ramene	High position setup	Einstellung höhererahmen
AI 2	Snímec výšky ramene	High position sensor	Sensor höhererahmen
AI 3	Nastavení microniseru	Microniser adjust	Einstellung Microniser
DI 1	Stop motor/cyklus	Stop motor/cycle	Stop motor/zyklus
DI 2	Start motor/cyklus	Start motor/cycle	Start motor/zyklus
DI 3	Světlák upnout	Clamp vice	Schraubstock spannen
DI 4	Světlák uvolnit	Release vice	Schraubstock lösen
DI 5	Total stop	Total stop	Totalstopp
DI 6	Horní kryt	Upper cover	Oberer Deckel
DI 7	Tlakový spínač	Pressure switch	Druckschalter
DI 8	Rameno dole	Arm is down	Rahmen is oben
DO 1	Cyklus	Cycle	Zyklus
DO 2	Horní kryt uzamčen/dyba	Cover locked/fault	Deckel verschlossen/fehler
DO 3	Rameno nahoru	Arm up	Rahmen nach oben
DO 4	Světlák upnout	Vice clamp	Schraubstock spannen
DO 5	Světlák uvolnit	Release vice	Schraubstock lösen
DO 6	Microniser	Microniser	Microniser
DO 7	Horní kryt odemčený	Cover unlocked	Deckel erschlossen
DO 8	Total stop	Total stop	Totalstopp



BOMAR, s.r.o.
Třebetín 1236/1
CZ 627 00, Brno

Spotřeba/Machine:

AL 400 semiautomatic

Název stránky/Name page/Name se list:

I/O řídicí systém / I/O Control station / I/O Steuerung





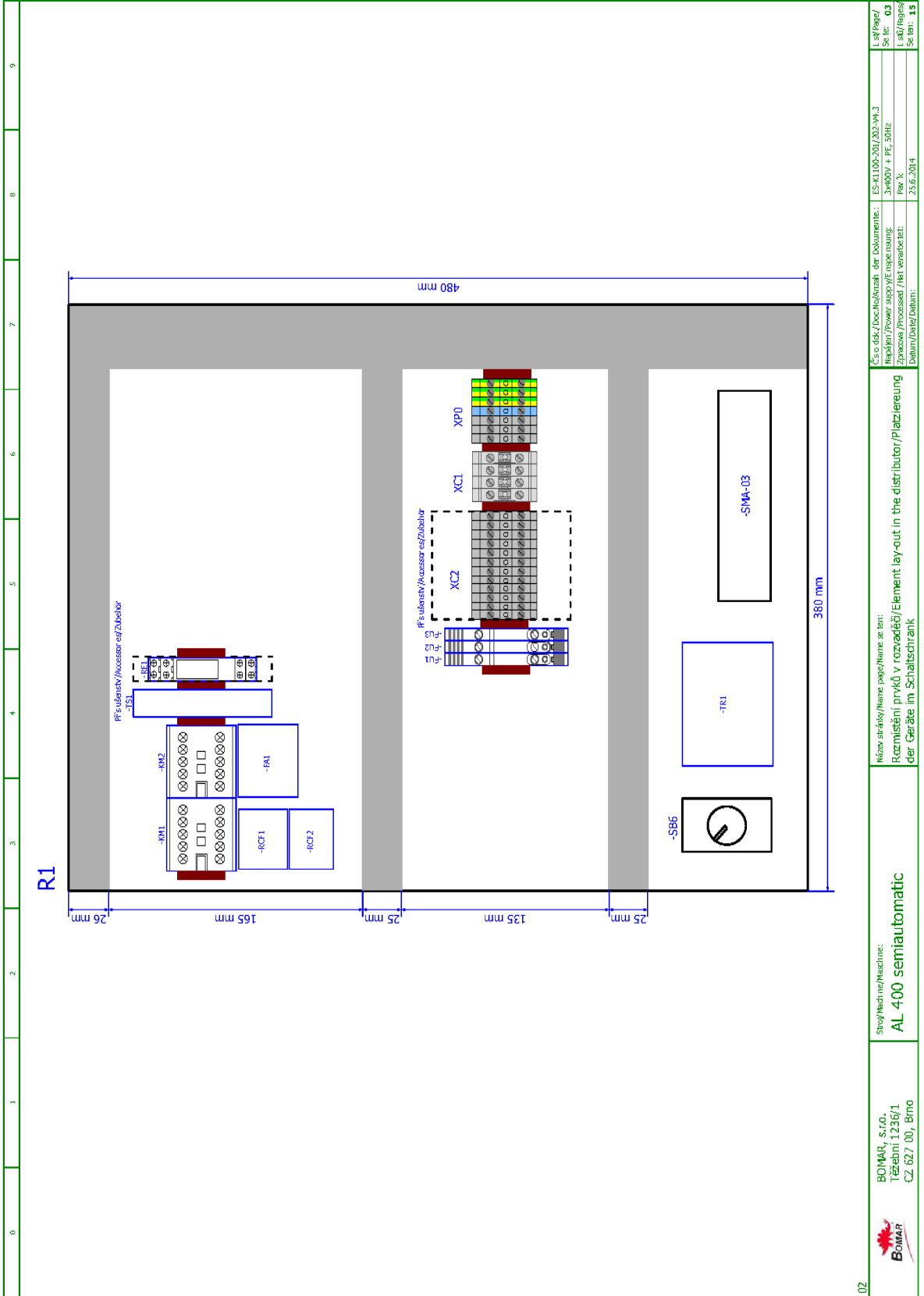

Číslo dok./Doc.No./Anzahl der Dokumenten.: ES-K100-01/02-V4.3
Název/Power supply/Energiezufuhr: 3x00V + PE, 50Hz
Zpracováno/Processed / Mit verarbeitet: Per. N.
Datum/Date/batum.: 23.6.2014

L. č./Page/
Se. č.: 02
L. sáz./Rechnung/
Se. len.: 15

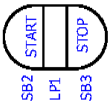



	<p>BOMAR, s.r.o. Třeboní 1236/1 CZ 627 00, Břno</p>	<p>Stroj/Mechne/Machine: AL 400 semiautomatic</p>	<p>Název stránky/Name page/Name se ten: Rozměstění prvků v rozvaděči/Element lay-out in the distributor/Platzierung der Geräte im Schaltschrank</p>	<p>Číslo dok./Doc.No/Kvzítel der Dokumentte: ES-K1100-03/02-VA-3 Regelger/Power supply/E respe insung: 3x400V + PE, 50Hz Ver. N. Datum/Date/datum: 25.6.2014</p>
02				L. sif/Page/
				Se. te. 03
				L. sif/Rege/
				Se. ten: 15

0	1	2	3	4	5	6	7	8	9				
<div style="border: 1px solid black; padding: 10px; display: flex; justify-content: space-around; align-items: center;"> <div style="text-align: center;">  <p>SB2 START LP1 SB3 STOP</p> </div> <div style="text-align: center;">  <p>SB4 LP2 SB5</p> </div> <div style="text-align: center;">  <p>SB1</p> </div> <div style="text-align: center;">  <p>SN3 sec/linp</p> </div> <div style="text-align: center;">  <p>SN1 o/p</p> </div> <div style="text-align: center;">  <p>LP3</p> </div> </div>													
 <p>BOMAR, s.r.o. Třebetín 1236/1 CZ 627 00, Brno</p>				<p>Společnost/Machine: AL 400 semiautomatic</p>				<p>Název stránky/Name page/Name seiten: Ovládací panel/Control Panel/Steuerpult</p>				<p>Číslo dok./Doc.No./Anzahl der Dokumenten.: ES-K100-01/02-V4.3 Repliken/Power supply/Ersatzleistung: 3x400V + PE, 50Hz Zpracováno/Processed/Her verarbeitet: Per. X. Datum/Datum: 23.6.2014</p>	
								<p>L. s. / Page / Se. / n. : 03</p>		<p>L. s. / Page / Se. / n. : 15</p>			

0	1	2	3	4	5	6	7	8	9
Parts list									
Device identification	Device description	Type number	Manufacturer	Part number	Quantity	Location (page,column)			
-CU1	Control Unit SMA 3.X	SMA 3.X	BOMAR s.r.o.	91.985.222	1	/09.1			
-FA1	Thermal Overload Relay - 7.6A	T16-7,6	ABB	91.050.027	1	/05.2			
-FU1	Fuse terminal	WK4/THSISU	WIELAND	91.251.102	1	/05.6			
-FU1	Tube fuse - 1A/250V, slow, 5x20	T1A/250V	ESKA	91.230.031	1	/05.6			
-FU2	Fuse terminal	WK4/THSISU	WIELAND	91.251.102	1	/05.6			
-FU2	Tube fuse - 1A/250V, slow, 5x20	T1A/250V	ESKA	91.230.031	1	/05.6			
-FU3	Tube fuse - 4A/250V, slow, 5x20	T4A/250V	ESKA	91.230.015	1	/05.8			
-FU3	Fuse terminal	WK4/THSISU	WIELAND	91.251.102	1	/05.8			
-KM1	Minicontactor - 4kW/400V, 3P	B65-30-01-1.7-71	ABB	91.040.049	1	/06.a.7			
-KM2	Minicontactor - 4kW/400V, 3P	B65-30-01-1.7-71	ABB	91.040.049	1	/06.a.8			
-LP1	White translucent switch head	M22-DL-W	EATON	91.060.038	1	/07.1			
-LP2	White light for Eaton adapter	M22-LED-W	EATON	91.061.034	1	/07.0			
-LP3/1	Indicating light - white, red	HIS-95 G/R 24V DC	ELECO	91.060.069	1	/07.2			
-QS1	Disconnecter - 3P, 16A	OT16FT3	ABB	91.170.018	1	/05.1			
-QS1	Handle switch - black	OHBS3RH	ABB	91.180.016	1	/05.1			
-RCF1	RCF filter	FBOPRL624	Ing. Miroslav Viřek	91.041.015	1	/05.2			
-RCF2	RCF filter	FBOPRL624	Ing. Miroslav Viřek	91.041.015	1	/05.2			
-RE1	Pluggable interface relay CR-P	CR-P024DC2	ABB	91.051.049	1	/07.8			
-RE1	CR-P Standard socket	CR-PSS	ABB	91.051.048	1	/07.8			
-SB1	Emergency-stop mushroom push - button + 3XNC	YW1B-V4E02R	IDEC	91.060.084	1	/06.5			
-SB2	Double button head white/black start/stop	M22-DDL-WS-GBI/G80	EATON	91.060.034	1	/06.2			
-SB2	Attaching adapter + 1NO	M22-AK10	EATON	91.061.021	1	/06.2			
-SB3	NO contact for Eaton adapter	M22-K10	EATON	91.061.022	1	/06.1			
-SB4	Double button head white/black, arrow close/open	M22-DDL-WS*	EATON	91.060.055	1	/06.3			
-SB4	Attaching adapter + 1NO	M22-AK10	EATON	91.061.021	1	/06.3			
-SB5	NO contact for Eaton adapter	M22-K10	EATON	91.061.022	1	/06.4			
-SB6/1	Attaching adapter + 1NC	M22-AK01	EATON	91.061.020	1	/06.5			
-SB6/1	Switch 2 positions	M22 - WKV	EATON	91.060.037	1	/06.5			

The manufacturer reserves right to use an equivalent replacement device.

03.a BOMAR, s.r.o. Třávní 1236/1 CZ 627 00, Brno		Step/Mech/Maschine: AL 400 semiautomatic		Název stránky/Name page/Name seiten: Kusovník artiklů/ Parts list/ Artikelstückliste		ES o.d.k./Doc/Kvazit. der Dokumenten: ES-K106-03/03-2V4.3		Lst/ Page/ Seite: 04	
				Napájecí/Power supply/Erspeisung: 3x400V + PE, 50Hz		Per. N. 25.6.2014		Lst/ Reply/ Seiten: 15	
				Datum/Date/datum: 25.6.2014					

0	1	2	3	4	5	6	7	8	9
Parts list									
Device identification	Device description	Type number	Manufacturer	Part number	Quantity	Location (page,column)			
-SB6/1	Button box DIN	M22-IVS	EATON	91.190.037	1	/06.5			
-SB6/2	NC contact for Eaton adapter	M22-K01	EATON	91.061.024	1	/06.a.8			
-SB6/3	NO contact for Eaton adapter	M22-K10	EATON	91.061.022	1	/06.6			
-SN1	Potenciometr 4k7	TP195 4k7/M20A	GES-ELECTRONICS, a.s.	91.283.015	1	/06.8			
-SN1	Potentiometer knob - 24mm	S8877 BLK	GES-ELECTRONICS, a.s.	91.060.063	1	/06.8			
-SN1	Fastconnect clamp	WAGO 224-112	WIELAND	91.250.009	3	/06.8			
-SN2	Position measuring	DH-RAIM	Bomar	262.012	1	/06.7			
-SN3	Potenciometr 4k7	TP195 4k7/M20A	GES-ELECTRONICS, a.s.	91.283.015	1	/06.8			
-SN3	Potentiometer knob - 24mm	S8877 BLK	GES-ELECTRONICS, a.s.	91.060.063	1	/06.8			
-SN3	Fastconnect clamp	WAGO 224-112	WIELAND	91.250.009	3	/06.8			
-SQ1	Head	ZCE10	TELEMECANIQUE	91.061.201	1	/06.a.1			
-SQ1	Switch body	ZCD31	TELEMECANIQUE	91.061.202	1	/06.a.1			
-SQ1	Cable gland	ZDEG11	TELEMECANIQUE	91.061.203	1	/06.a.1			
-SQ2	Guard Lock Safety-door with solenoid 24V	D4NL-4HFA-B	OMRON	91.173.040	1	/08.3			
-SQ3	Guard Lock Safety-door with solenoid 24V	D4NL-4HFA-B	OMRON	91.173.040	1	/07.4			
-TRL1	Toroidal transformer - 400V/230V/20V 4,5A 90VA	400V/230V/20V 4,5A 90VA	KARBAN s.r.o.	91.060.023	1	/05.7			
-TS1	Multifunction time relay - 12-240V, 10 functions	CRM-91H/UNI	ELKO	91.051.027	1	/08.1			

The manufacturer reserves right to use an equivalent replacement device.

 BOMAR, s.r.o. Tržební 1236/1 CZ 627 00, Brno	Společnost/Name: AL 400 semiautomatic	Název stránky/Name page/Name seiten: Kusovník artiklů/ Parts list/ Artikelstückliste	Číslo dok./DocNo./Anzahl der Dokumenten: ES-K100-031/02-V4.3	L. št./Page/ Se. nr.: 04
	Spon/Power supply/Energieversorgung: Zdrojova /Processed / Mit verarbeitet: Datum/Dating/datum: 23.6.2014	Per. k.: 23.6.2014	L. št./Page/ Se. nr.: 15	

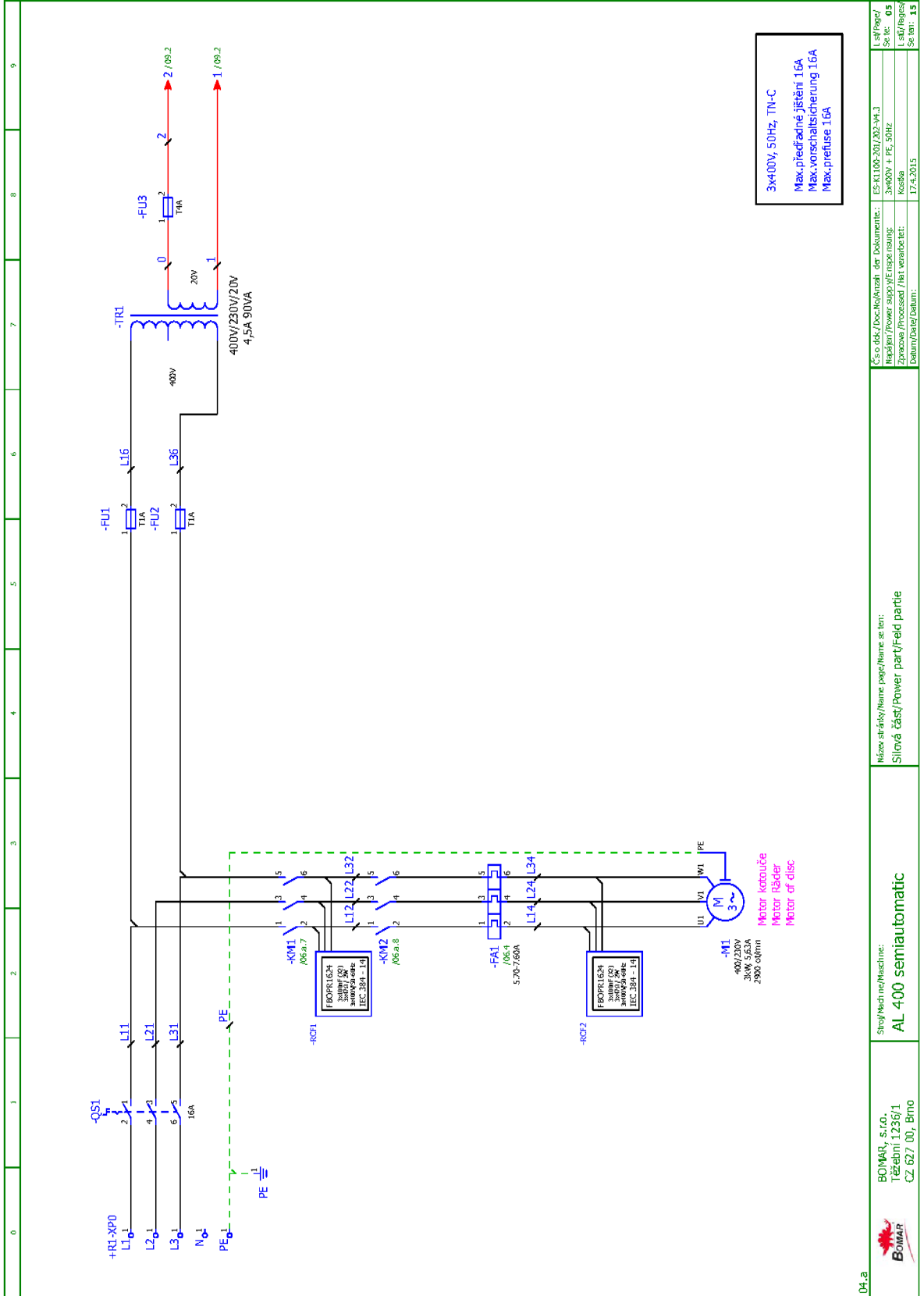

3x400V, 50Hz, TN-C
Max.předřadné jističní 16A
Max.vorschaltungsicherung 16A
Max.prefuse 16A

04_a	BOMAR, s.r.o. Třebetín 1236/1 CZ 627 00, Brno	Stroj/Mechine/Maschine: AL 400 semiautomatik	Název schémát/Name page/Name seiten: Slovová část/Power part/Feld partie	Číslo dok./Doc.No/Anzahl der Dokumentte.: ES-K100-201/202-V4-3 Napájecí/power supply/E.rspe.itzung: 3x400V + PE, 50Hz Zpracováno /Processed / Mit verarbeitet: Kosska Datum/Dating/datum: 17.4.2015	L.stř./Page/ Se.ite: 05 L.stř./Reihe/ Se.iten: 15
------	---	--	---	--	--

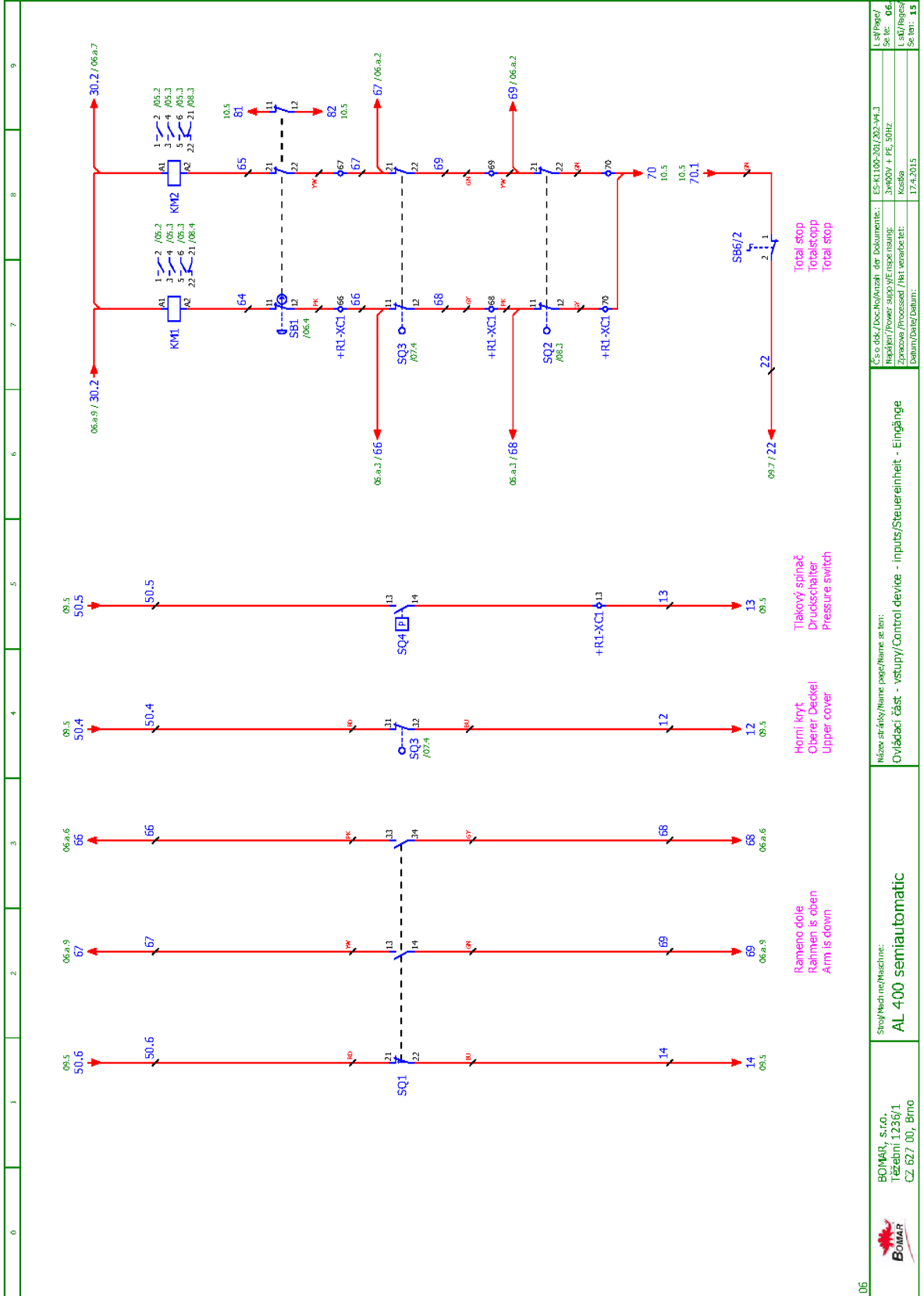

Horní kryt
Oberer Deckel
Upper cover

Rameno dole
Rahmen is oben
Arm is down

Tlakový spínač
Druckschalter
Pressure switch

Total stop
Totalstopp
Total stop

<p>ES o.dok./DocNo/Anzahl der Dokumente: ES-K100-03/03-VA-3 Repagen/Power supply/Erspeisung: 3x400V + PE, 50Hz Zpracováno/Processed/ Mit verarbeitet: Kosska Datum/Date/ Datum: 17.4.2015</p>		<p>Li.st/ Page/ Seite: 06 Li.st/ Repage/ Seite: 15</p>
<p>Název strojů/Name page/Name: se ten: Ovládací část - vstup/Control device - inputs/Steuerinheit - Eingänge</p>	<p>Stroj/Mechine/Maschine: AL 400 semiautomatic</p>	<p>06</p>

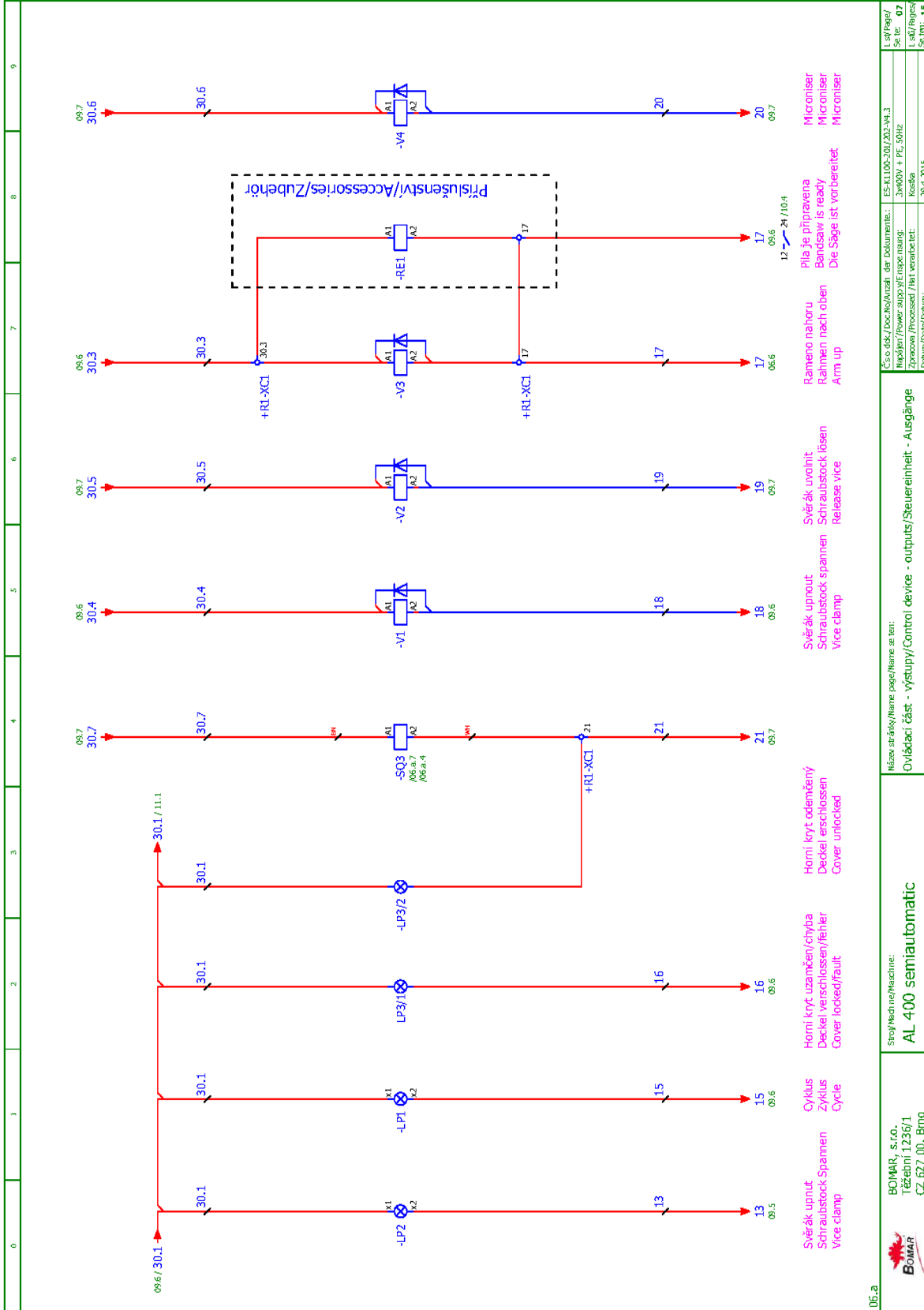

06.a

Název stroje/Machine: AL 400 semiautomatic Společnost/Firma: BOMAR, s.r.o. Tržební území: CZ 627 00, Brno		Název stroje/Machine: ES-K100-201/202-V4.3 Napájení/Power supply/Energie: 3x400V + PE, 50Hz Zpracováno/Processed / Mit verarbeitet: Koska Datum/Datum: 29.4.2015	
Ovládací část - výstupy/Control device - outputs/Steuerinheit - Ausgänge		L. št./Page/ Str. č./ L. št./Reihe/ Str. č./	

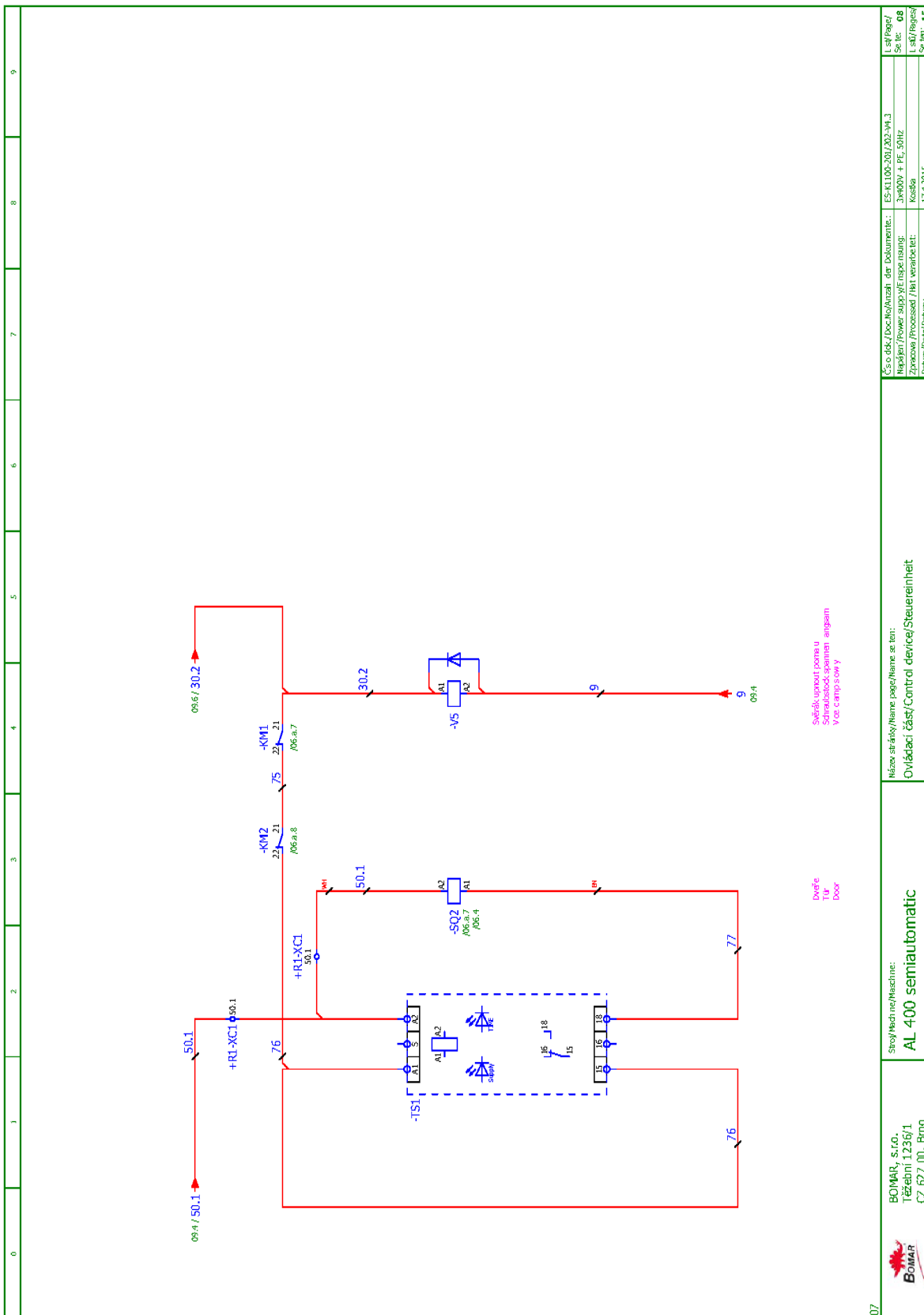

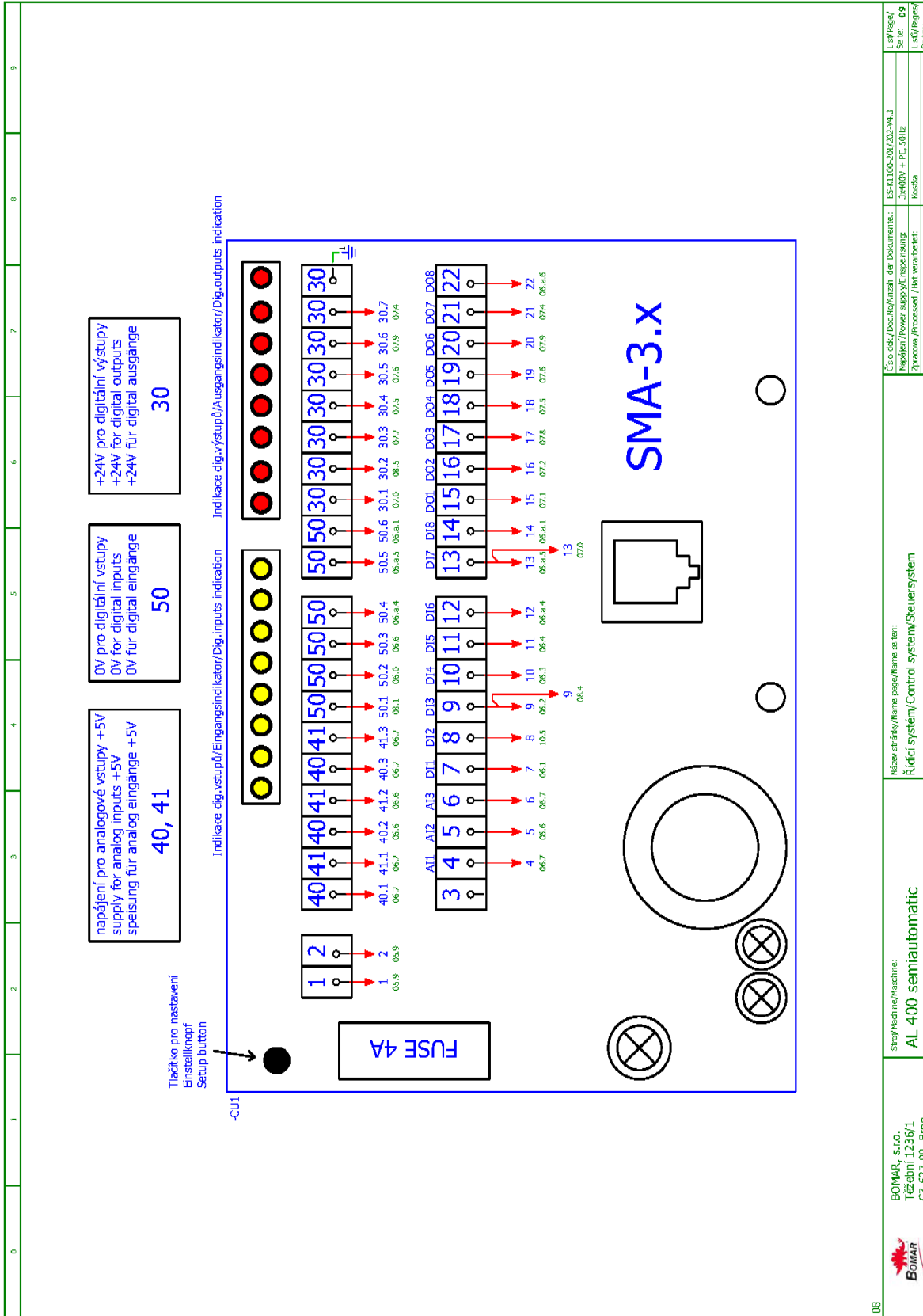

08	BOMAR, s.r.o. Třeborní 1236/1 CZ 627 00, Brno	Společnost/Name: AL 400 semiautomatic	Název stránky/Name page/frame seiten: Řídicí systémy/Control system/Steuer system	Cs o dok./DocNo/Anzahl der Dokumenten: ES-K100-01/202-V4.3 Hesájen/Power supply/Energieinsatz: 3x000V + PE, 50Hz Koska Datum/Dating/datum: 17.4.2015	LH Page/ Seite: L. sál./Rehly/ Seite: 09
----	---	---	---	--	--

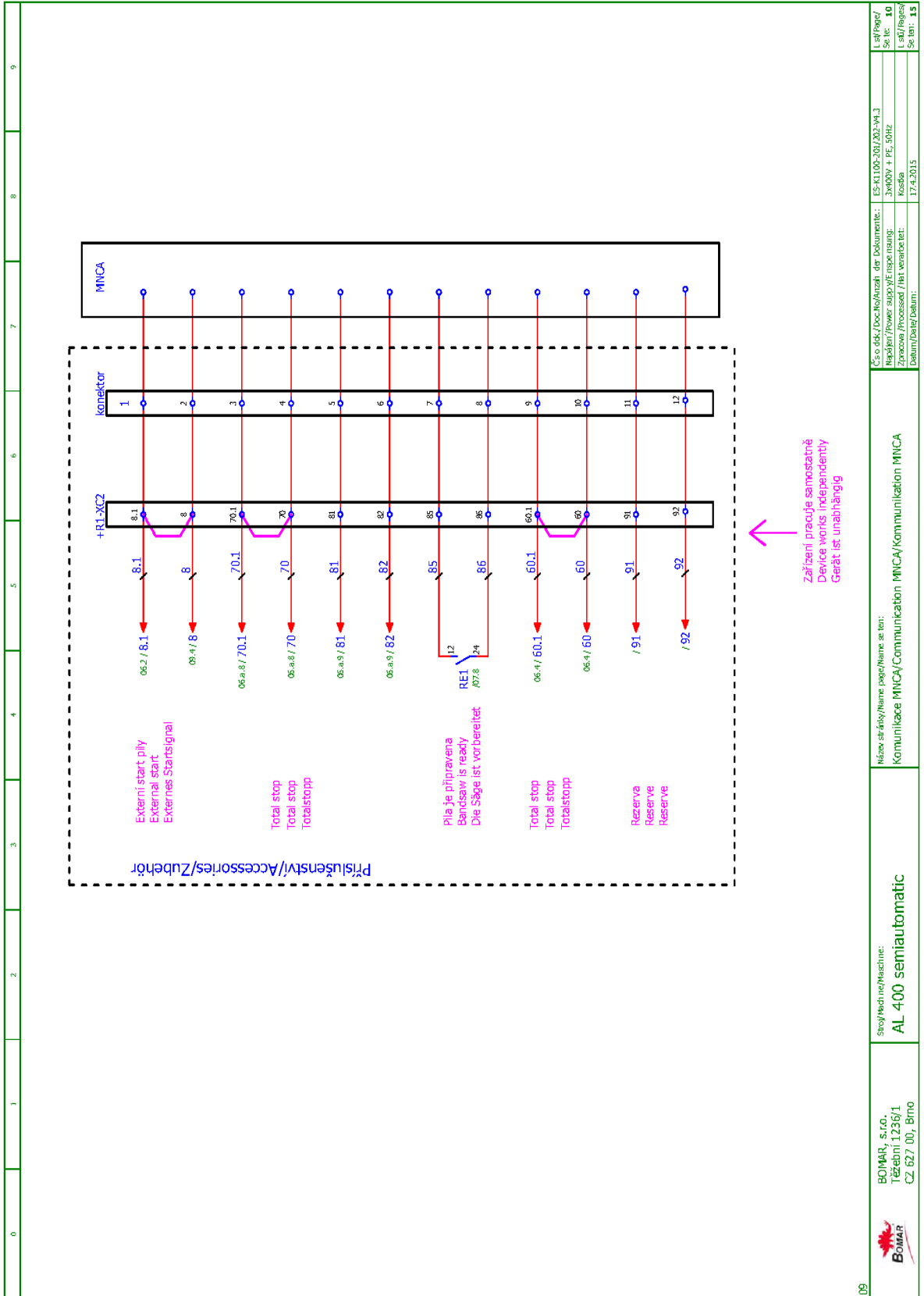

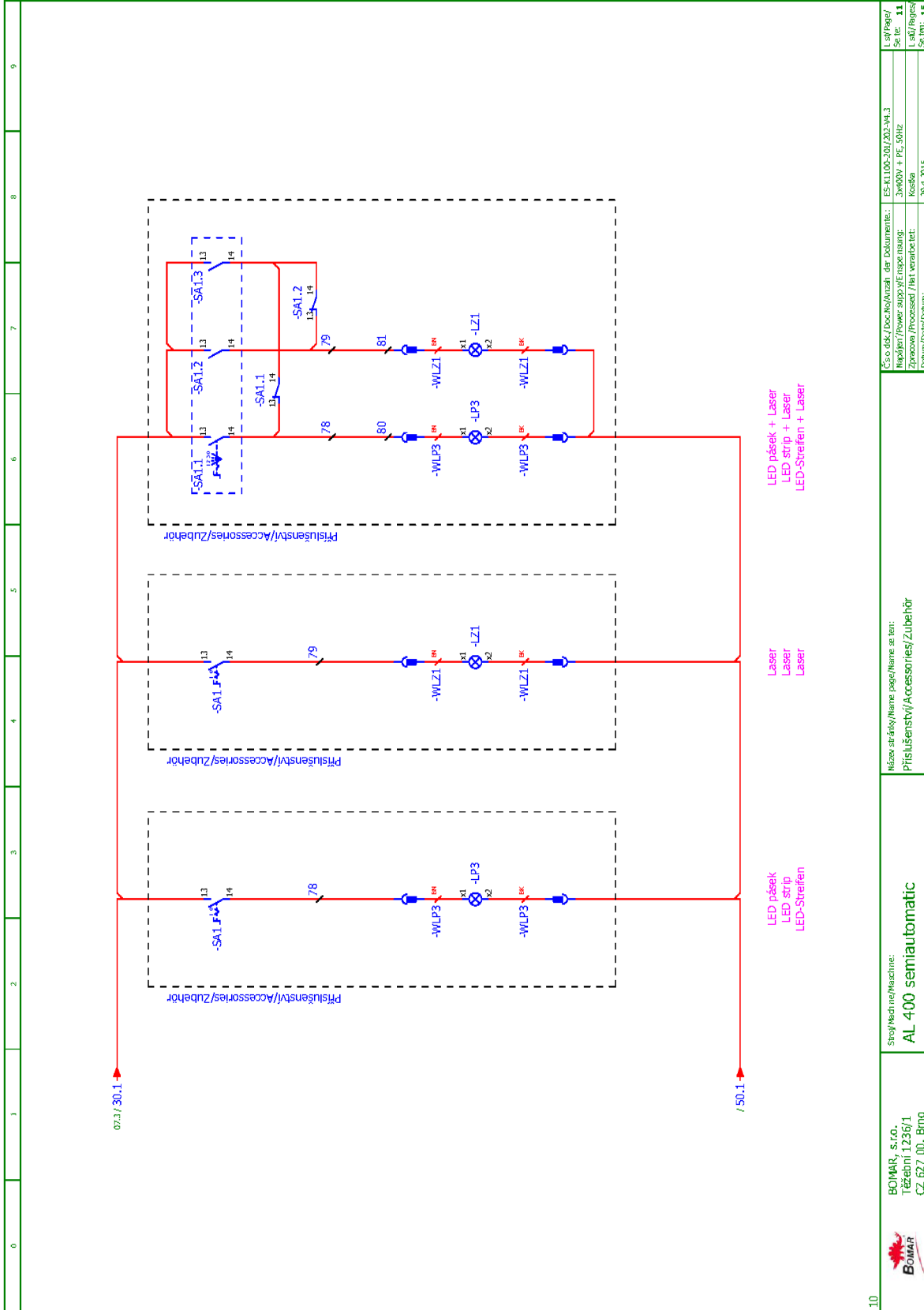

<p>BOMAR, s.r.o. Třebetín 1236/1 CZ 627 00, Brno</p>	<p>Stroj/Mechine/Maschine: AL 400 semiautomatic</p>	<p>Název stroje/Name page/Name se ten: Komunikace MNCA/Communication MNCA/Kommunikation MNCA</p>	<p>Číslo dok./Doc.No/Anzahl der Dokumente: ES-K100-03/02-V4-3 Napájení/Power supply/E.rspeisung: 3x400V + PE, 50Hz Zpracováno/Processed / Mit verarbeitet: Kosska Datum/Dating/datum: 17.4.2015</p>
	<p>09</p>	<p>L. s. / Page / Se. It. 10 L. s. / Page / Se. It.: 15</p>	



<p>BOMAR, s.r.o. Těžebrní 1236/1 CZ 627 00, Brno</p>	<p>Spoločnosť/Maschine: AL 400 semiautomatic</p>	<p>Název stránky/Name page/Name seiten: Príslušenstv./Accessories/Zubehör</p>	<p>CS o.d.k./DocNo/Anzahl der Dokumenten: ES-K100-001/02-V4.3</p> <p>Región/Power supply/Erspeisung: 3x400V + PE, 50Hz</p> <p>Zpracova/Processed/Her verarbeitet: Koska</p> <p>Datum/Dating/Datum: 29.4.2015</p>	<p>L. s. / Page / Seite: 11</p> <p>L. s. / Page / Seite: 15</p>
--	---	---	--	---

**Schemata
Schemata
Schematics**

5.4. Elektrické schéma /Elektroschema /Wiring diagrams –
bez frekv. měnič e/ ohne Frequenzumrichter /without
Frequency convertor – 3×230 V+PE,50Hz

0	1	2	3	4	5	6	7	8	9	
 <p>AL 400 semiautomatic ES-K1100-203-V4.3 Wiring diagram 3x230V + PE, 50Hz</p> <p>Bomar, spol. s r.o. Těžební 1236/1 627 00 Brno Czech republic</p>										
										
BOMAR, s.r.o. Těžební 1236/1 CZ 627 00, Brno			Spis/Techn/Mechine: AL 400 semiautomatic				Název stránky/Name page/Name seiten: Úvodní strana/ Start page/ Startseite		Číslo dok./Doc.No/Anzahl der Dokumente: ES-K100-203-V4.3 Napájení/Power supply/Einspeisung: 3x230V + PE, 50Hz Zpracováno /Processed / Mit verarbeitet: Koska Datum/Dating/datum: 20.4.2015	List/Page/ Seite: 00 List/Reihen/ Seiten: 15

0	1	2	3	4	5	6	7	8	9
Table of contents									
Page	Page name							Date	
00	Úvodní strana/ Start page/ Startseite							20.4.2015	
01	Obsah/ Table of contents/ Inhaltsverzeichnis							20.4.2015	
02	I/O řídicí systém / I/O Control station / I/O Steuerung							25.6.2014	
03	Rozmístění prvků v rozvaděči/Element lay-out in the distributor/Platzierung der Geräte im Schaltschrank							25.6.2014	
03.a	Ovládací panel/Control Panel/Steuerpult							25.6.2014	
04	Kusovník artiklů/ Parts list/ Artikelstückliste							20.4.2015	
04.a	Kusovník artiklů/ Parts list/ Artikelstückliste							20.4.2015	
05	Silová část/Power part/Feld parte							20.4.2015	
06	Ovládací část - vstupy/Control device - inputs/Steuerinheit - Eingänge							20.4.2015	
06.a	Ovládací část - vstupy/Control device - inputs/Steuerinheit - Eingänge							20.4.2015	
07	Ovládací část - výstupy/Control device - outputs/Steuerinheit - Ausgänge							20.4.2015	
08	Ovládací část/Control device/Steuerinheit							20.4.2015	
09	Řídicí systém/Control system/Steuersystem							20.4.2015	
10	Komunikace MMCA/Communication MMCA/Kommunikation MMCA							20.4.2015	
11	Příslušenství/Accessories/Zubehör							20.4.2015	
00	 BOMAR, s.r.o. Těžební 1236/1 CZ 627 00, Brno	Společnost/Name: AL 400 semiautomatic	Název stránky/Name page/Name seiten: Obsah/ Table of contents/ Inhaltsverzeichnis	Číslo dok./Doc.No./Anzahl der Dokumente: ES-K100-203-V4.3	Datum/Datum: 20.4.2015	L. st./Page/ Se. nr.: L. st./Reihe/ Se. nr.:	01 01 15		

0	1	2	3	4	5	6	7	8	9
---	---	---	---	---	---	---	---	---	---

AL 400 semiautomatic

I/O	CZE	ENG	DE
AI 1	Nastavení výšky ramene	High position setup	Einstellung höherahmen
AI 2	Snímač výšky ramene	High position sensor	Sensor höherahmen
AI 3	Nastavení microniseru	Microniser adjust	Einstellung Microniser
DI 1	Stop motor/cyklus	Stop motor/cycle	Stop motor/zyklus
DI 2	Start motor/cyklus	Start motor/cycle	Start motor/zyklus
DI 3	Světlák upnout	Clamp vice	Schraubstock spannen
DI 4	Světlák uvolnit	Release vice	Schraubstock lösen
DI 5	Total stop	Total stop	Totalstopp
DI 6	Horní kryt	Upper cover	Oberer Deckel
DI 7	Tlakový spínač	Pressure switch	Druckschalter
DI 8	Rameno dole	Arm is down	Rahmen is oben
DO 1	Cyklus	Cycle	Zyklus
DO 2	Horní kryt uzamčen/dchyba	Cover locked/fault	Deckel verschlossen/fehler
DO 3	Rameno nahoru	Arm up	Rahmen nach oben
DO 4	Světlák upnout	Vice clamp	Schraubstock spannen
DO 5	Světlák uvolnit	Release vice	Schraubstock lösen
DO 6	Microniser	Microniser	Microniser
DO 7	Horní kryt odemčený	Cover unlocked	Deckel erschlossen
DO 8	Total stop	Total stop	Totalstopp

HW	FW

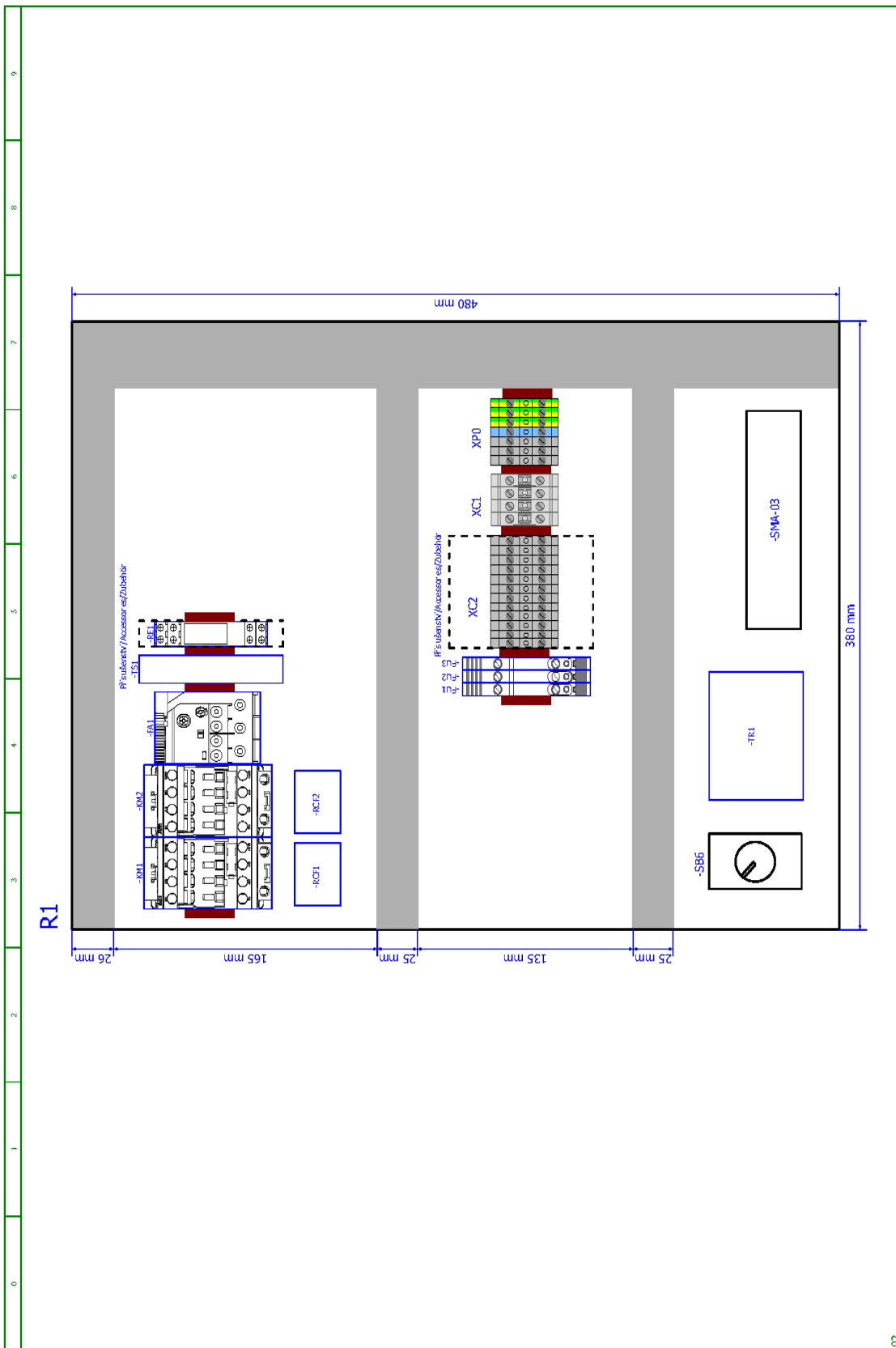

<p>BOMAR, s.r.o. Třebetín 1236/1 CZ 627 00, Brno</p>	<p>Společnost/Machine: AL 400 semiautomatic</p> <p>Název stránky/Name page/Name se stran: Rozmístění prvků v rozvaděči/Element layout in the distributor/Platzierung der Geräte im Schaltschrank</p>	<p>Číslo dok./Doc.No./Anzahl der Dokumente: ES-K100-203-V4.3</p> <p>Región/Power supply/Einspeisung: 3x230V + PE, 50Hz</p> <p>Zpracováno/Processed/Her verarbeitet: Per. X.</p> <p>Datum/Datum: 23.6.2014</p>	<p>L. s. H. Page/ 03</p> <p>Se. It. 03</p> <p>L. s. H. Page/ 15</p> <p>Se. It. 15</p>
--	--	---	---

Schemata
Schemata
Schematics

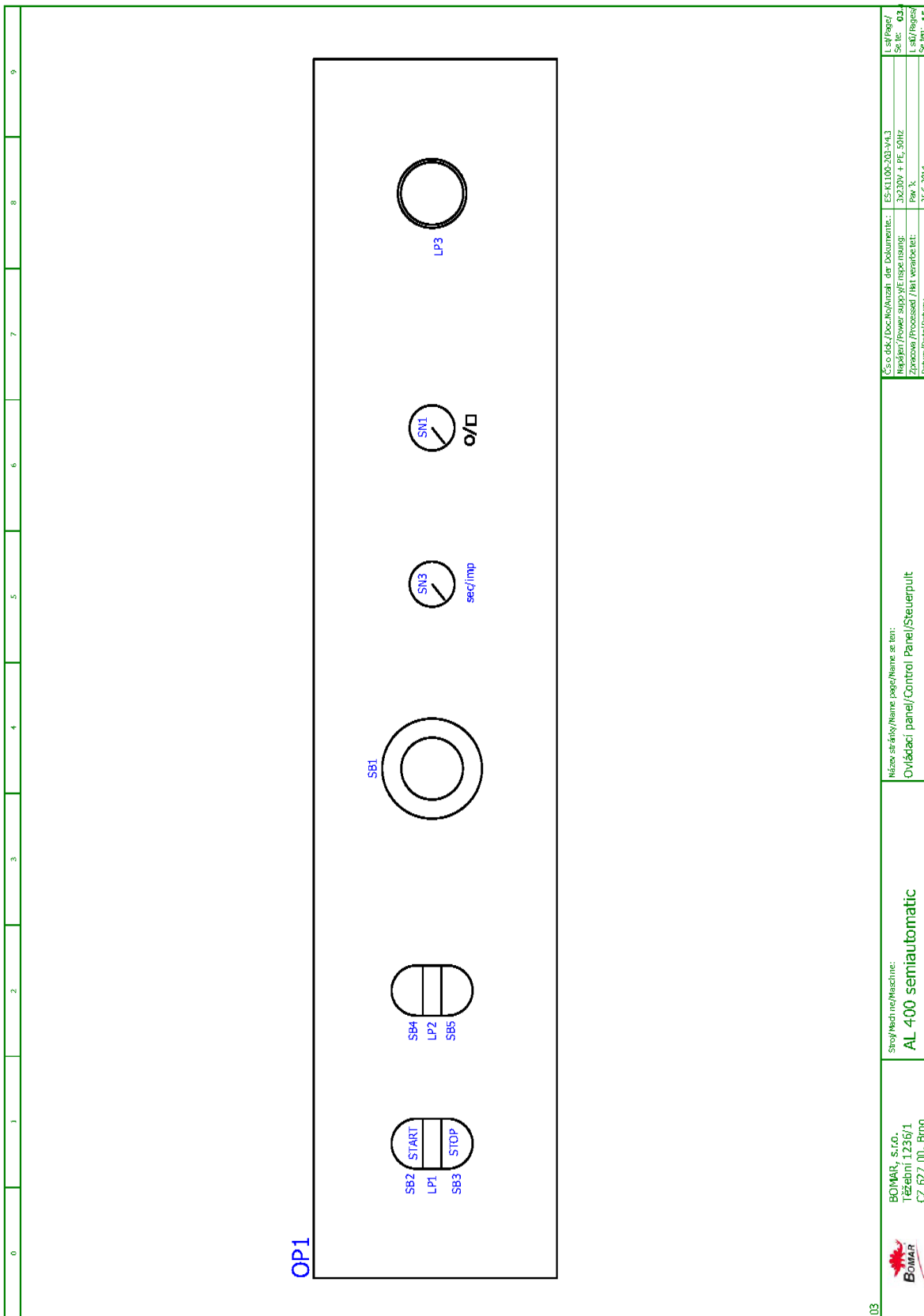

03

 BOMAR, s.r.o. Třebetín 1236/1 CZ 627 00, Brno	Stroj/Machine/Maschine: AL 400 semiautomatic	Název stránky/Name page/Name seiten: Ovládací panel/Control Panel/Steuerpult	Číslo dok./Doc.No./Anzahl der Dokumente: ES-K100-203-V4.1 Model/Power supply/Einspeisung: 3x230V + PE, 50Hz Zpracováno /Processed / Mit verarbeitet: Per. N. Datum/Dating/datum: 25.6.2014
			List/Page/ Seite: 03 List/Reihe/ Serien: 15

0	1	2	3	4	5	6	7	8	9
Parts list									
Device identification	Device description	Type number	Manufacturer	Part number	Quantity	Location (page,column)			
-CU1	Control unit SMA 3.X	SMA 3.X	BOMAR s.r.o.	91.995.222	1	/09.1			
-FA1	Thermal relay - 10A	T16-10	ABB	91.050.028	1	/05.2			
-FA1	Holder of thermal relay	DB16	ABB	91.990.031	1	/05.2			
-FU1	Fuse terminal	WK4/THSISU	WIELAND	91.251.102	1	/05.6			
-FU1	Tube fuse - 1A/250V, slow, 5x20	T1A/250V	ESKA	91.230.031	1	/05.6			
-FU2	Fuse terminal	WK4/THSISU	WIELAND	91.251.102	1	/05.6			
-FU2	Tube fuse - 1A/250V, slow, 5x20	T1A/250V	ESKA	91.230.031	1	/05.6			
-FU3	Tube fuse - 4A/250V, slow, 5x20	T4A/250V	ESKA	91.230.015	1	/05.8			
-FU3	Fuse terminal	WK4/THSISU	WIELAND	91.251.102	1	/05.8			
-KM1	Contact - 5.5KW/400V, 3P	AF12-30-01-11	ABB	91.040.051	1	/06.a.7			
-KM2	Contact - 5.5KW/400V, 3P	AF12-30-01-11	ABB	91.040.051	1	/06.a.8			
-LP1	The head backlit buttons white	M22-DL-W	EATON	91.060.038	1	/07.1			
-LP2	White light for Eaton adapter	M22-LED-W	EATON	91.061.034	1	/07.0			
-LP3/1	LED red and green common ground 24V DC	HIS-95 G/R 24V DC	ELECO	91.060.069	1	/07.2			
-QS1	Disconnect - 3P, 16A	OT16FT3	ABB	91.170.018	1	/05.1			
-QS1	Handle switch - black	OHB3RH	ABB	91.160.016	1	/05.1			
-RCF1	Efferent RFC filter	FBOPRL624	Ing. Miroslav Vřětek	91.041.015	1	/05.2			
-RCF2	Efferent RFC filter	FBOPRL624	Ing. Miroslav Vřětek	91.041.015	1	/05.2			
-RE1	Plug-in relay	CR-P024DC2	ABB	91.051.049	1	/07.8			
-RE1	Relay socket	CR-PSS	ABB	91.051.048	1	/07.8			
-SB1	Emergency-stop mushroom push - button + 3XNC	YW1B-V4E02R	IDEC	91.060.084	1	/06.5			
-SB2	Double button head white/black start/stop	M22-DDL-WS-GBI/G80	EATON	91.060.034	1	/06.2			
-SB2	Attaching adapter + 1NO	M22-AK10	EATON	91.061.021	1	/06.2			
-SB3	NO contact for Eaton adapter	M22-K10	EATON	91.061.022	1	/06.1			
-SB4	Double button head white/black, arrow close/open	M22-DDL-WS*	EATON	91.060.055	1	/06.3			
-SB4	Attaching adapter + 1NO	M22-AK10	EATON	91.061.021	1	/06.3			
-SB5	NO contact for Eaton adapter	M22-K10	EATON	91.061.022	1	/06.4			
-SB6/1	Attaching adapter + 1NC	M22-AK01	EATON	91.061.020	1	/06.5			
<p>The manufacturer reserves right to use an equivalent replacement device.</p>									
BOMAR, s.r.o. Třebetín 1236/1 CZ 627 00, Brno		Společnost/Name: AL 400 semiautomatic		Název stránky/Name page/Name seiten: Kusovník artiklů/ Parts list/ Artikelstückliste		ES o.dok./DocNo./Anzahl der Dokumenten.: ES-K100-203-V4.3 Název/Power supply/Energieversorgung: 3x230V + PE, 50Hz Zpracováno/Processed /Mit verarbeitet.: Kaska Datum/Dating/datum.: 20.4.2015		L.č./Page/ Seite: 04 L.č./Page/ Seite: 15	

0	1	2	3	4	5	6	7	8	9	
Parts list										
Device identification	Device description	Type number	Manufacturer	Part number	Quantity	Location (page,column)				
-SB6/1	Switch 2 positions	M22 - WKV	EATON	91.060.037	1	/06.5				
-SB6/1	Box, click on the DIN	M22-IVS	EATON	91.190.037	1	/06.5				
-SB6/2	NC contact for Eaton adapter	M22-K01	EATON	91.061.024	1	/06.a.8				
-SB6/3	NO contact for Eaton adapter	M22-K10	EATON	91.061.022	1	/06.6				
-SW1	Potentiometer 4k7	TP195 4k7/N20A	GES-ELECTRONICS, a.s.	91.283.015	1	/06.8				
-SW1	Head of potentiometer 24mm	S8877 BLK	GES-ELECTRONICS, a.s.	91.060.063	1	/06.8				
-SW1	Fastconnect clamp	WAGO 224-112	WAGO	91.250.009	3	/06.8				
-SW2	Position measuring	DH-RAIM	Bomar	262.012	1	/06.7				
-SW3	Potentiometer 4k7	TP195 4k7/N20A	GES-ELECTRONICS, a.s.	91.283.015	1	/06.8				
-SW3	Head of potentiometer 24mm	S8877 BLK	GES-ELECTRONICS, a.s.	91.060.063	1	/06.8				
-SW3	Fastconnect clamp	WAGO 224-112	WAGO	91.250.009	3	/06.8				
-SQ1	Head	ZCE10	TELEMECANIQUE	91.061.201	1	/06.a.1				
-SQ1	The switch body	ZCD31	TELEMECANIQUE	91.061.202	1	/06.a.1				
-SQ1	Cable gland	ZDEG11	TELEMECANIQUE	91.061.203	1	/06.a.1				
-SQ2	Safety Limit Switch with 24V coil	D4NL-4HFA-B	OMRON	91.173.040	1	/08.3				
-SQ3	Safety Limit Switch with 24V coil	D4NL-4HFA-B	OMRON	91.173.040	1	/07.4				
-TR1	Toroidal transformer - 400V / 230V / 20V 4,5A 90VA	400V/230V/20V 4,5A 90VA	KARBAN s.r.o.	91.060.023	1	/05.7				
-TS1	Multifunction time relay - 12-240V, 10 functions	CRM-91H/UNI	ELKO	91.051.027	1	/08.1				

The manufacturer reserves right to use an equivalent replacement device.

 BOMAR, s.r.o. Třebíč 1236/1 CZ 627 00, Brno		Stroj/Mechine/Machine: AL 400 semiautomatic		Název strojů/Name page/Name se ten: Kusovník artiklů/ Parts list/ Artikelstückliste		ES o.d.k./Doc.No/Anzahl der Dokumenten.: ES-K106-203-V4.3 Napájení/Power supply/E.nsp.einslung.: 3x230V + PE, 50Hz Zpracováno/Processed /Mit verarbeitet.: Kosska Datum/Dating/datum.: 20.4.2015		L.st/Pages/ Se. te.: 04 L.st/Replies/ Se. ten.: 15	
--	--	---	--	--	--	---	--	---	--

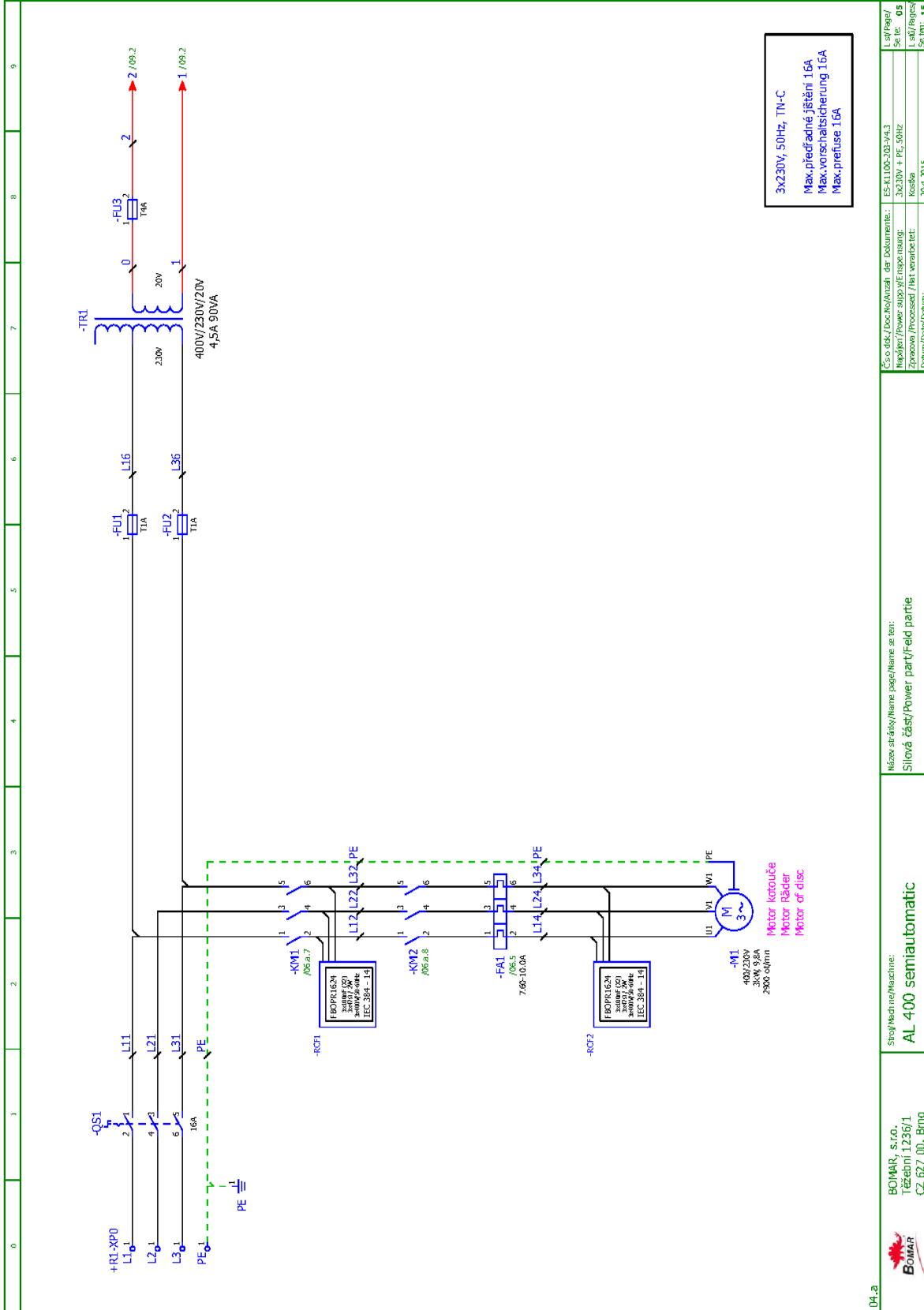

3x230V, 50Hz, TN-C
 Max. předřadné jističní 16A
 Max. vorschaltssicherung 16A
 Max. prefuse 16A

04_a	Spoj/Mechine/Nameine: AL 400 semiautomatic	Název stránky/Name page/Name seiten: Slovová část/Power part/Feld partie	Číslo dok./DocNo/Anzahl der Dokumenten: ES-K100-203-V4.3	Liš/Page/ Seite: 05
	BOMAR, s.r.o. Třebetín 1236/1 CZ 627 00, Brno		Regulátor/Power supply/Energieausstattung: 3x230V + PE, 50Hz	
			Zpracovatel/Processed/Her verarbeitet: Koska	Liš/Page/ Seite: 05
			Datum/Dating/Datum: 20.4.2015	Liš/Page/ Seite: 15

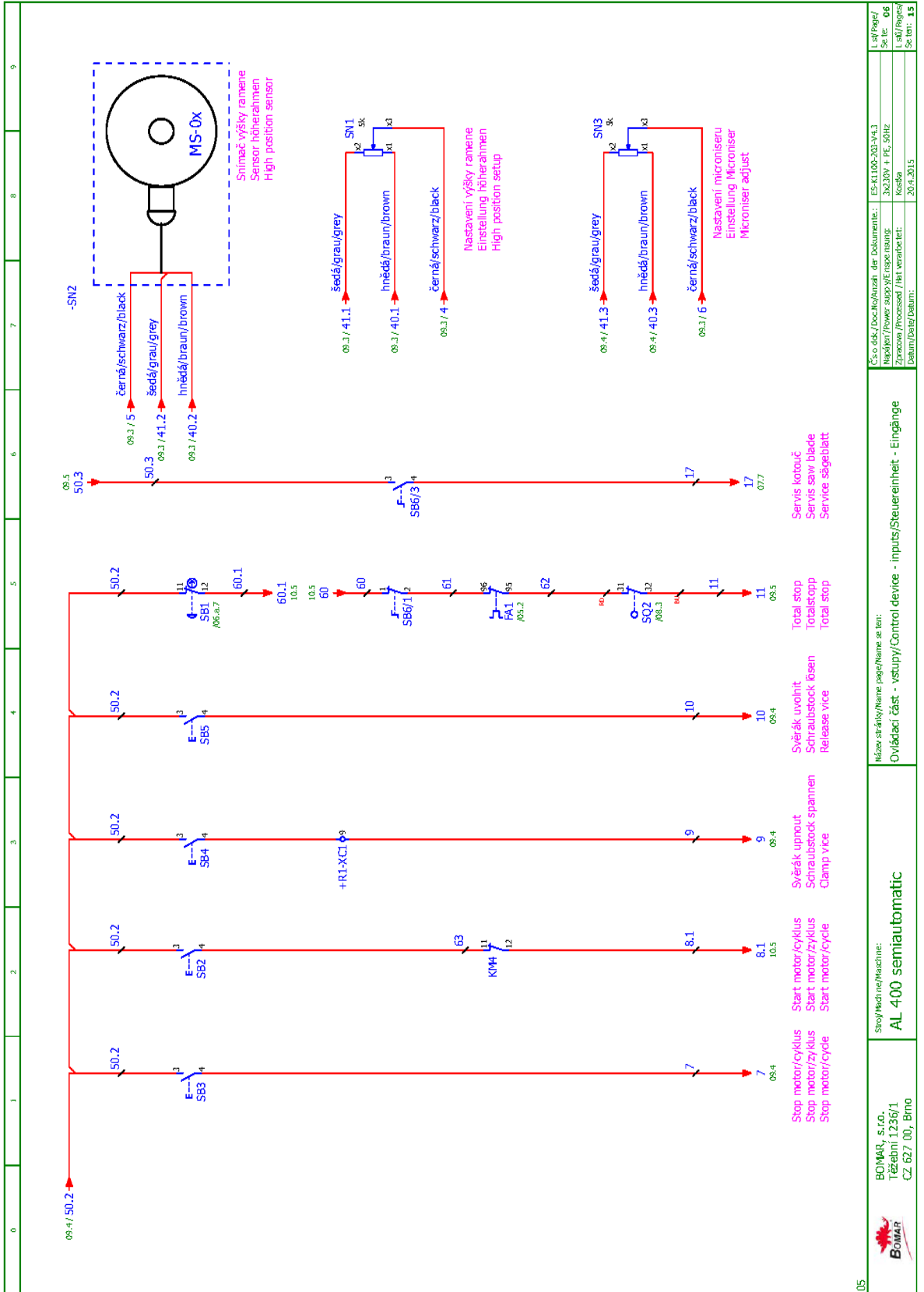

05



BOMAR, s.r.o.
Třeboní 1236/1
CZ 627 00, Brno

Stroj/Machine:
AL 400 semiautomatic

Název stránky/Name page/Name seiten:
Ovládací řád - vstup/Control device - inputs/Steuereinheit - Eingänge

Úroveň/Level/Level:
L 01/02/03/04/05/06

Seřazení/Ordering/Reihenfolge:
3.02.03V + PE, 50Hz

Datum/Dating/Date:
20.4.2015

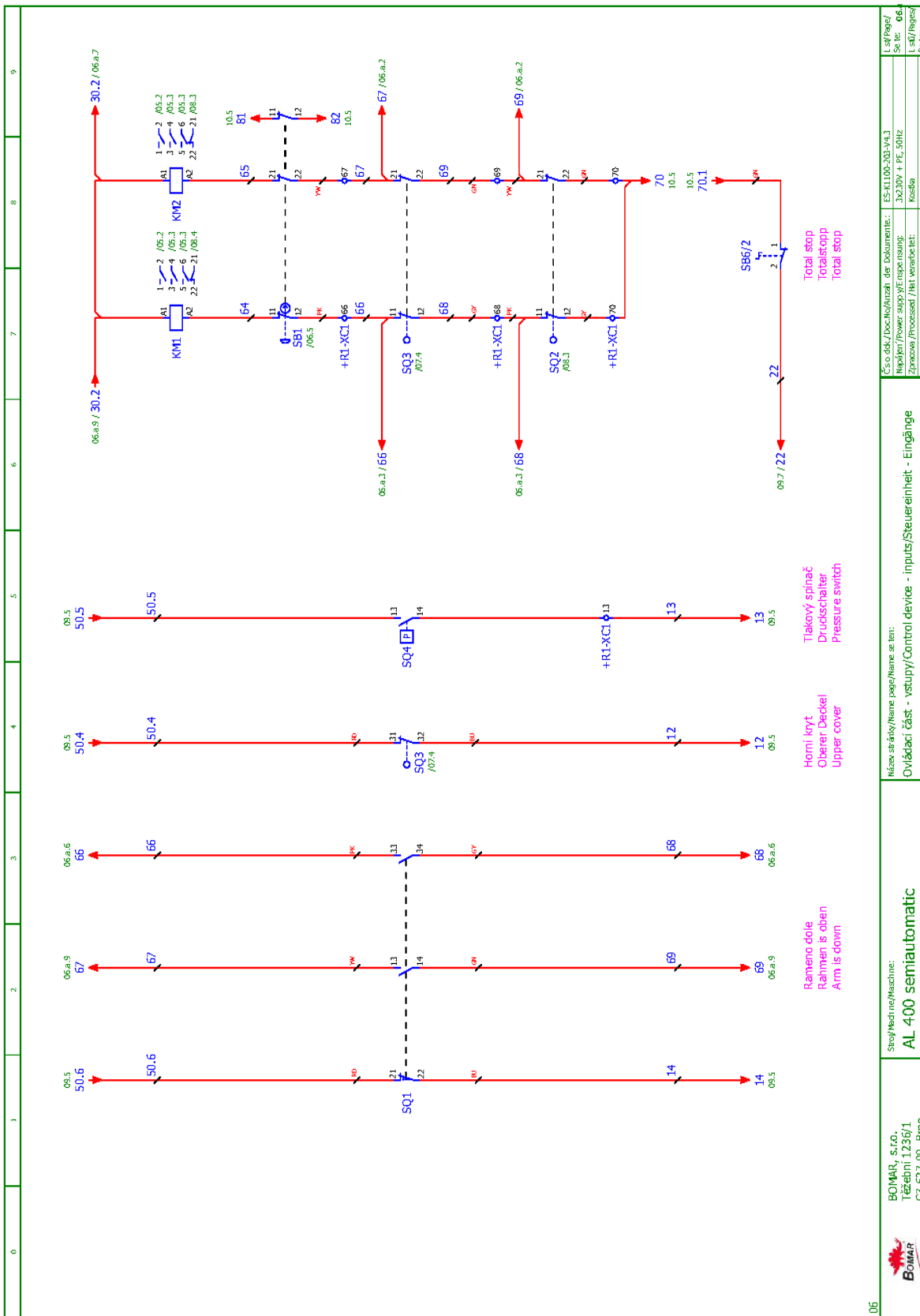

06

<p>BOMAR, s.r.o. Třebetín 1236/1 CZ 627 00, Brno</p>	<p>Spoj/Mechine/Maschine: AL 400 semiautomatic</p>	<p>Název strojů/Name page/Name se ten: Ovládací část - vstup/Control device - inputs/Steuerinheit - Eingänge</p>	<p>Číslo dok./Doc.No./Anzahl der Dokumenten: ES-K100-03-V4.3 Hrající/Power supply/Einspeisung: 3x230V + PE, 50Hz Zpracová/Processed /Mit verarbeitet: Koska Datum/Dating/datum: 20.4.2015</p>
		<p>L: 347/Rechn: Seite: 06 Seiten: 15</p>	

Schemata Schemata Schematics

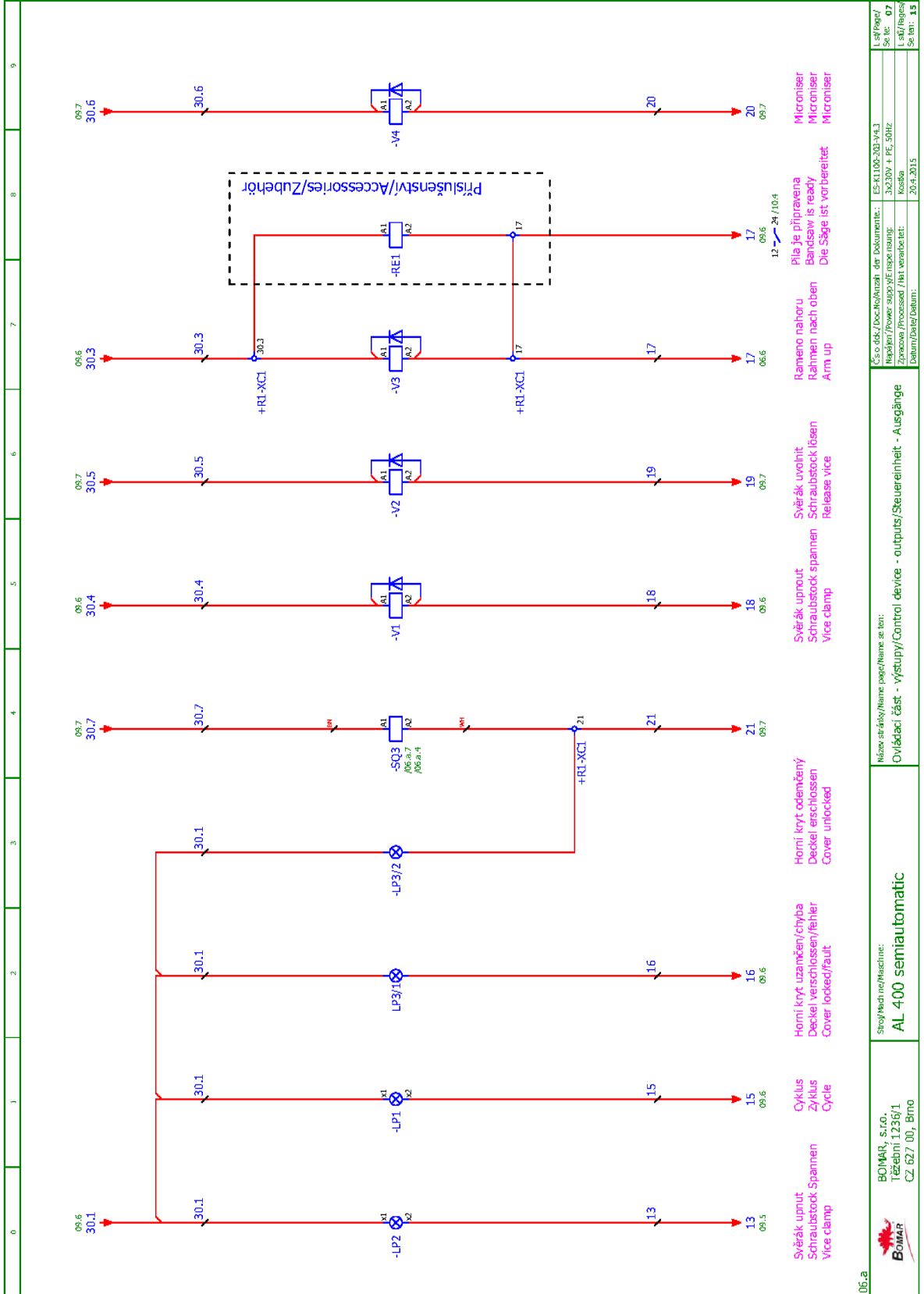

06.a

Stroj/Mechine/Maschine:
AL 400 semiautomatic

BOMAR, s.r.o.
Třeborní 1236/1
CZ 627 00, Brno

Název schémky/Name page/Name seiten:

Ovládací část - výstupy/Control device - outputs/Steuerinheit - Ausgänge

L.č./Page/
Se.č.: 07
L.č./Reihe/
Seiten: 15

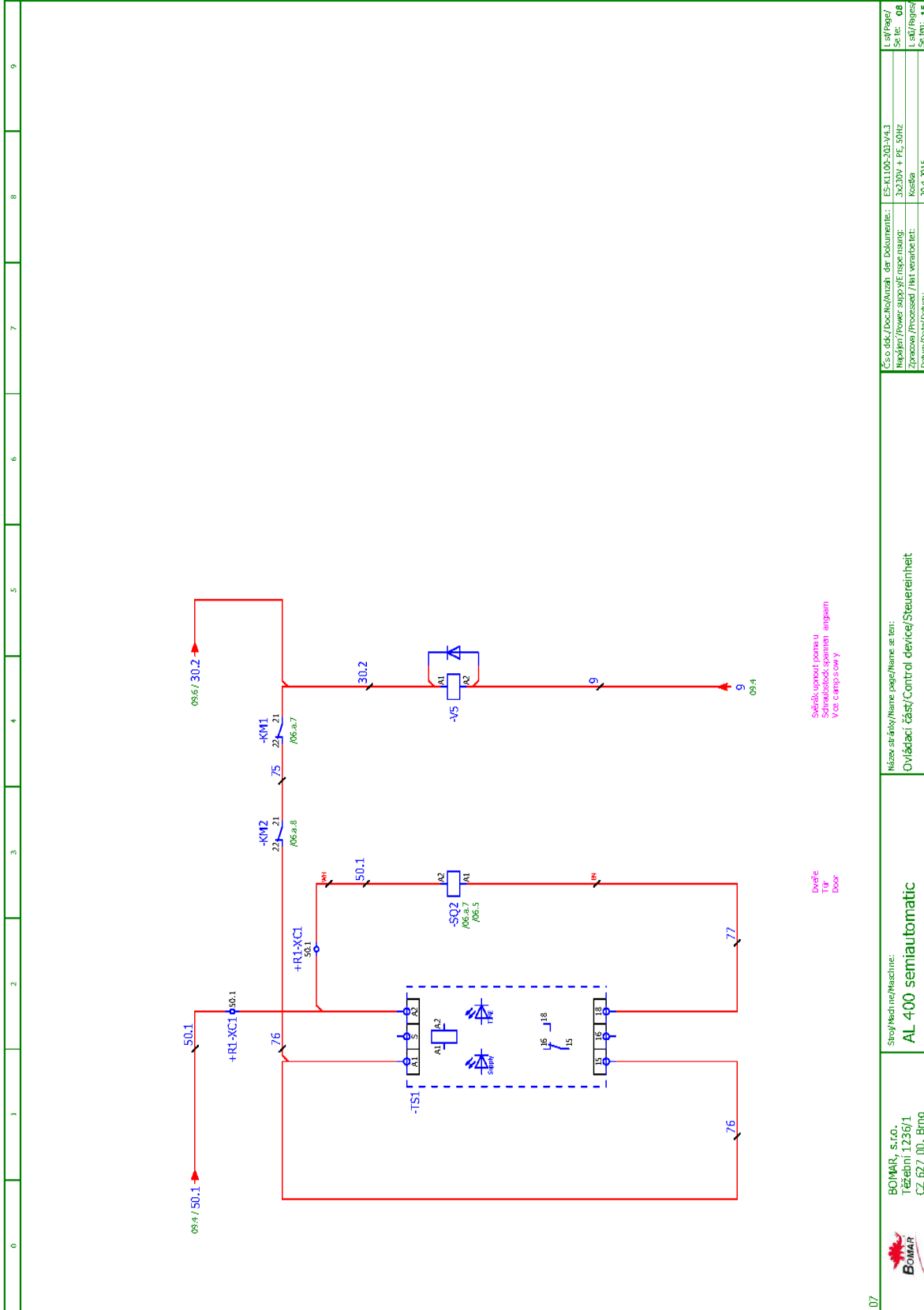

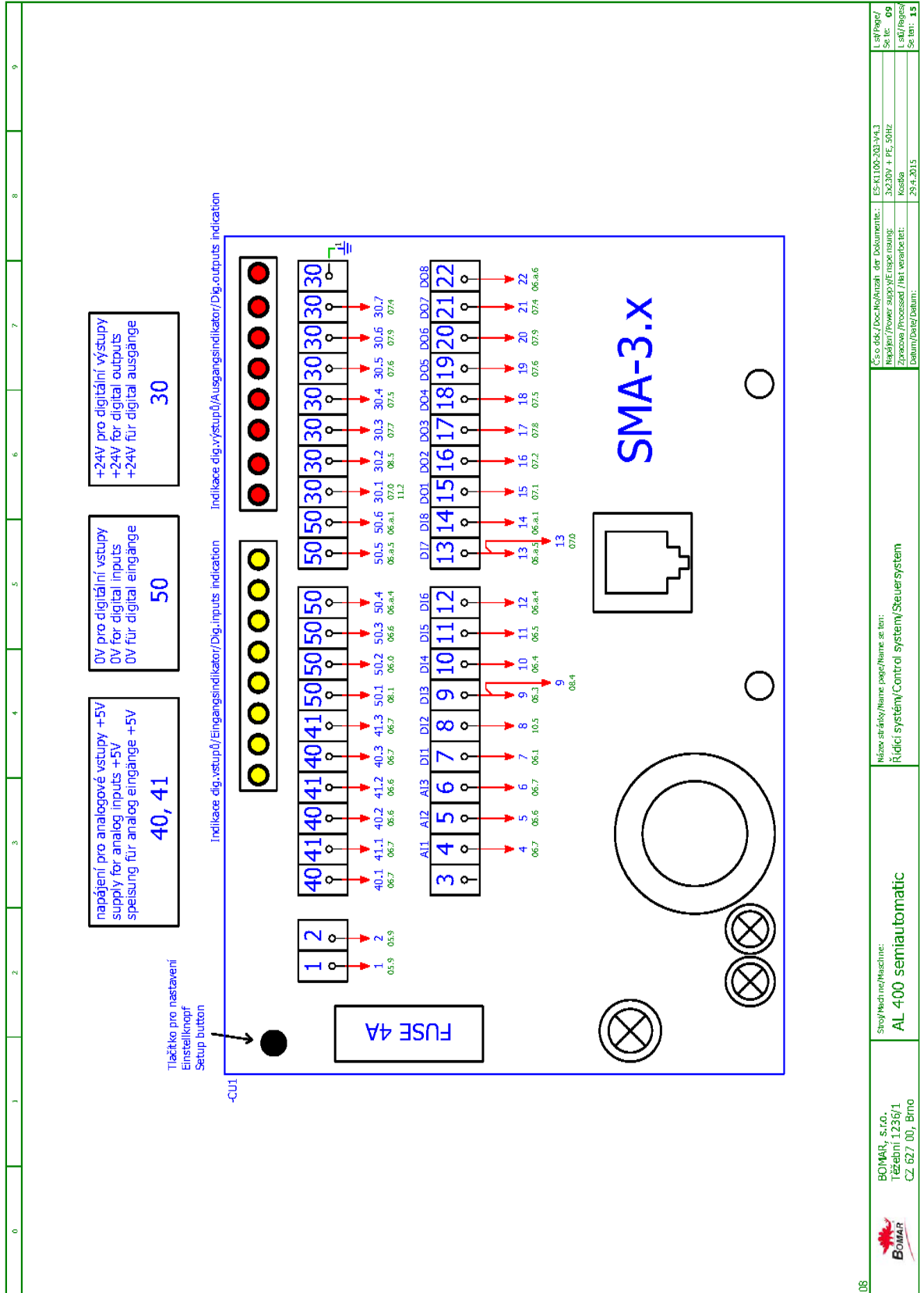

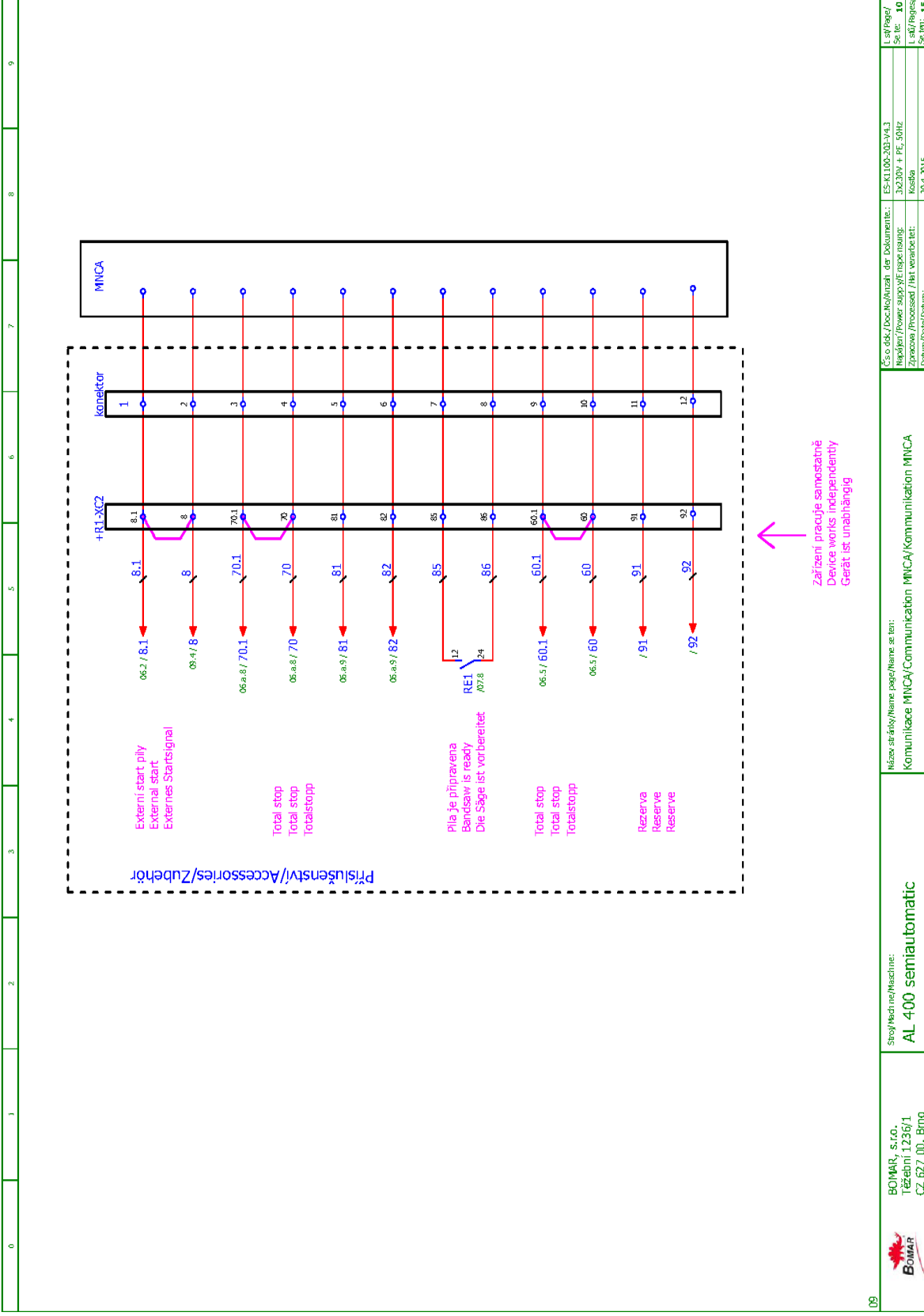

BOMAR, s.r.o.
Třeborní 1236/1
CZ 627 00, Brno

Spoločnosť/Name of Machine:
AL 400 semiautomatic

Názov strojky/Name of machine se ten:
Komunikace MINCA/Communication MINCA/Kommunikation MINCA

CS o.d.k./Doc.No./Anzahl der Dokumenten.: ES-K100-203-V4.3
Napájení/Power supply/Energie nábija: 3x230V + PE, 50Hz
Zpracováva/Processed / Mit verarbeitet: Kossika
Datum/Dating/batum.: 20.4.2015

L. s. / Page /
Se. tit.: 10
L. s. / Page /
Se. tit.: 15

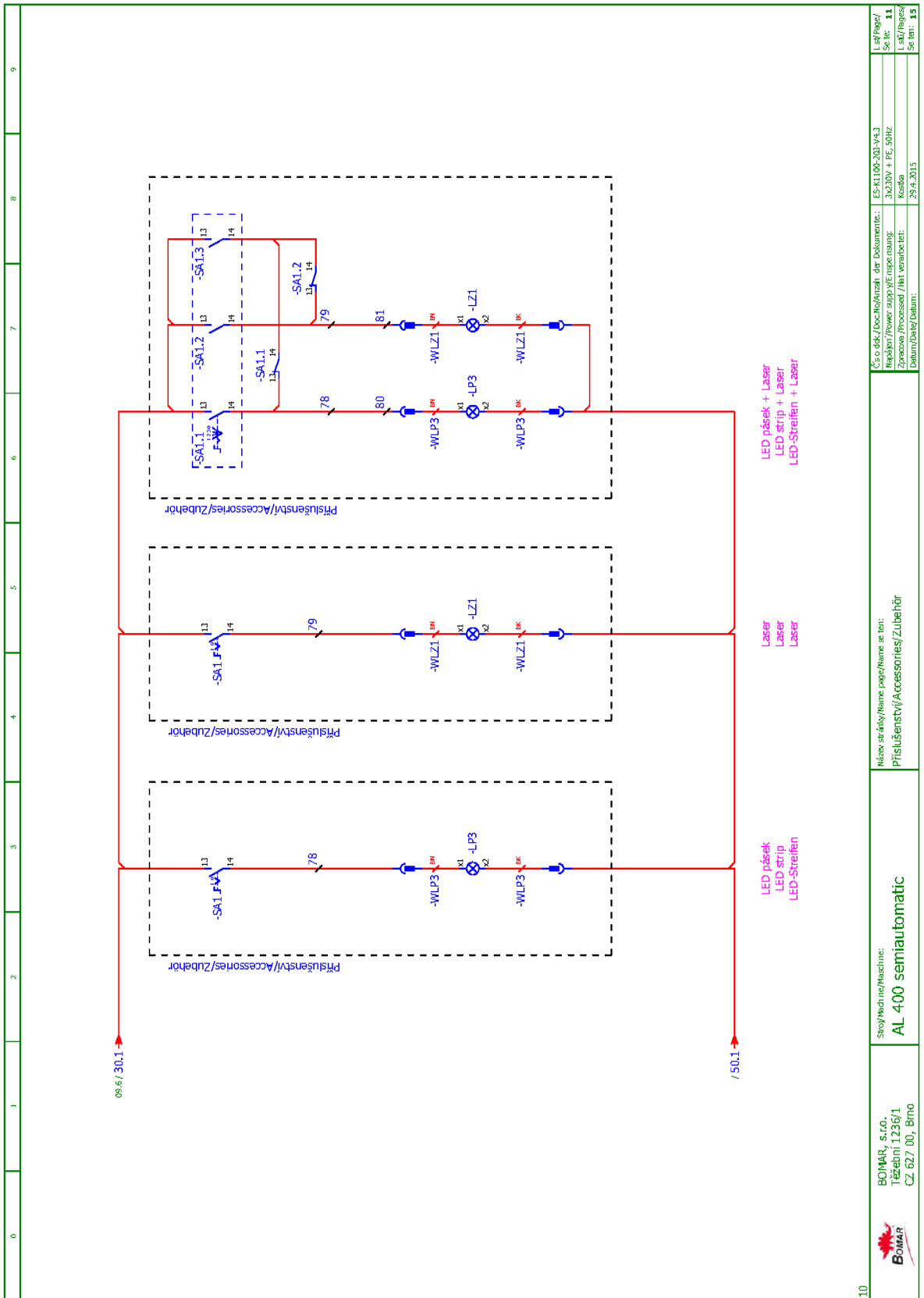

<p>BOMAR, s.r.o. Třebízni 1236/1 CZ 627 00, Brno</p>	<p>Stroj/Mechine/Machine: AL 400 semiautomatic</p>	<p>Název stroje/Name page/Name of item: Přislůženstv/Accessories/Zubehör</p>	<p>Číslo dok./Doc.No/Anzahl der Dokumenten: ES-K100-203-V4.3</p>	<p>Lisť/Page/ Seite: 11</p>
	<p>30.2kV + PE, 50Hz</p>	<p>Typ stroje/Type of machine: Koska</p>	<p>Regulátor/Power supply/Ersatzleistung: 30.2kV + PE, 50Hz</p>	<p>Seit: 11</p>
		<p>Datum/Dating/Date: 29.4.2015</p>	<p>Typ stroje/Type of machine: Koska</p>	<p>Seit: 15</p>

**Schemata
Schemas
Schematics**

5.5. Pneumaticko-hydraulické schéma /
Pneumatik-Hydraulikschema /
Pneumatic-Hydraulic diagram

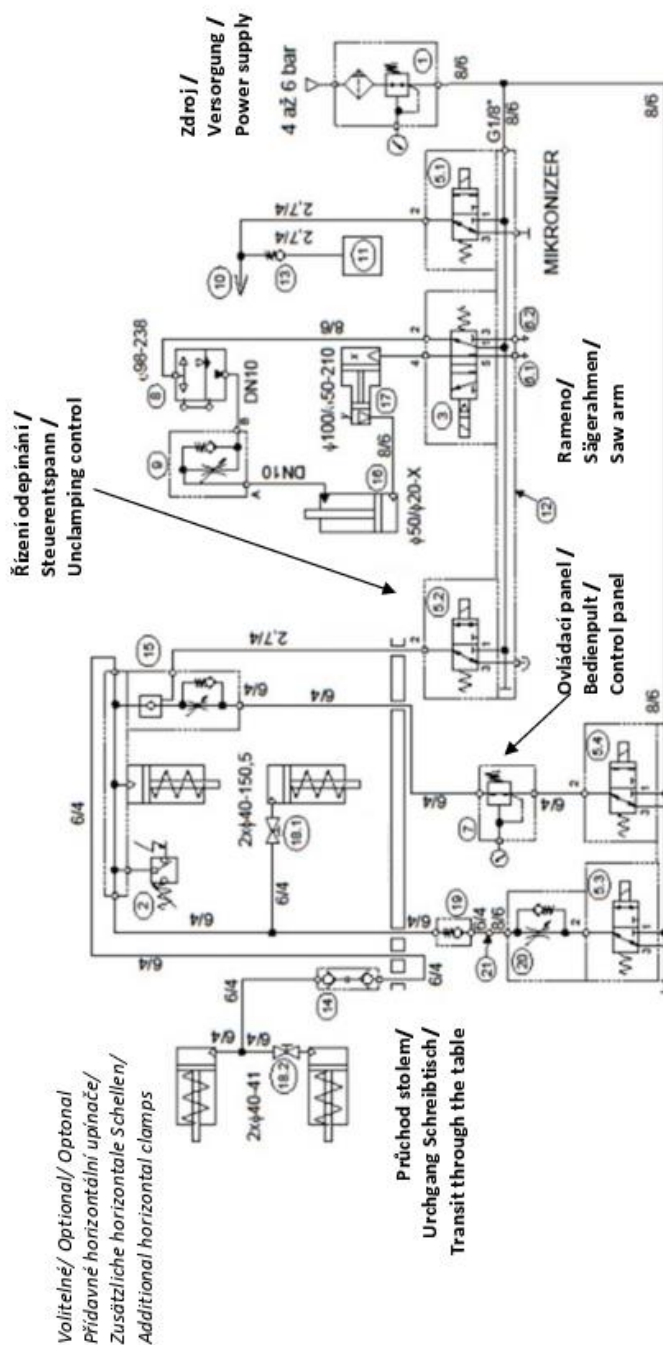

Volitelné / Optional / Optional
Přídavné horizontální upínače /
Zusätzliche horizontale Schellen /
Additional horizontal clamps

Příchod stolem /
Urgang Schreibtisch /
Transit through the table

- Svěráky / Schraubstocke / Vices
- Pomalé upínání / Langsam Spann / Slow clamping
- Normální upínání / Normale Spann / Slow clamping
- Přídavné horizontální upínače (se samičí rychlospojky č. 14) a regulace tlaku svěráku (7) – volitelné vybavení
- Hydraulický minerální olej HLP46 na úseku mezi prvky č. 8-16
- DN10 – hydraulická hadice PN 40bar
- Prvek č. 17 (MULTIPLIKÁTOR) pouze u stroje ALU 600
- Prvek č. 14 – samec rychlospojky – instalován vždy
- Zusätzliche horizontale Schellen (mit Frauen Kupplungen 14) und umge Druckkontrolle (17) – optional
- Hydrauliköl auf Mineralöl HLP46 der Abschnitt zwischen den Elementen 8-16
- DN10 – Hydraulikschlauch PN 40bar
- Element nicht 17 (Multiplikator) nur Maschinen ALU 600
- Teil Nr. 14 - männlich Kupplungen - immer installiert
- Additional horizontal clamps (and female coupling 14) and vice pressure control – optional.
- Hydraulic mineral oil HLP46 between pieces No. 8-16
- DN10 – Hydraulic hose PN 40bar
- Part No. 17 (MULTIPLIKÁTOR) at machine ALU 600 only
- Part No. 14 – male coupling -always installed

Poz.	Název položky		ks
Pos.	Bezeichnung		Menge
Pos.	Item		Pcs.
1	Redukční ventil / Reduktionsventil / Control valve	93.003.001	1
2	Tlakový spínač / Druckschalter / Pressure switch	92.201.004	1
3	Rozvaděč / Verteilungsventil / Distributor	93.002.003	1
4	Rozvaděcí kostka/ Verteilung Würfel / Distribution Cube	30.1505-704	1
5	Rozvaděč / Verteilungsventil / Distributor	93.001.008	4
6	Tlumič / Dämpfer / Inhibitor	93.014.003 G1/8"	2
7	Redukční ventil / Reduktionsventil / Control valv (volitelné vybavení/ optional)	93.002.004	1(0)
8	Výměník / AUSTAUSCHER / exchanger	201.K107-300 V=1,785dm ³	1
9	Škrťící ventil / Drosselventil / Throttle-valve	92.152.013 (ALU 400,500) VS01-04/R3,5-O6S 92.152.011 (ALU 600) VS01-04/R3,5-O6	1
10	MIKRONIZER	99.150.002	1
11	Nádrž / Behälter / Tank	94.404.001 0,5dm ³	1
12	Rozvaděcí kostka/ Verteilung Würfel / Distribution Cube	30.0915-101	1
13	Jednosměrný ventil / Einwegventil / One-way valve	93.024.001	1
14	Rychlospojka / Schnellkupplung / Gladhand Část „samice“ – volitelné vybavení (horizontální upínače), část „samec“ instalována vždy/ Die "weiblich" - optional (horizontal Klemmen), die "männliche" immer installiert/ The "female" - optional (horizontal clamps), the "male" always installed	93.023.001/002 G1/4"	1
15	Ventil pojistný / Sicherungsventil / Retaining valve	93.021.002 SMC JAPAN	1
16	Zvedací válec / Hubzylinder / Lifting cylinder	201.K107-000 (ALU400) X=175 201.K307-000 (ALU500) X=228 201.K407-000 (ALU600) X=173	1
17	MULTIPLIKÁTOR (4x) Pouze u stroje/ Nur Maschinenú Only for machine AL 600	201.K415-000	1
18	Ventil uzavírací / Ventil / Valve	99.260.001	2(1)
19	Ventil / Rückschlagventil / non-return valve	93.021.009	1
20	Škrťící ventil / Drosselventil / Throttle-valve	93.021.004 G1/8- 8/6	1
21	Redukce/ Reduktion/ Reduction	93.023.067	

6. **Výkresy sestav pro objednání náhradních dílů / Zeichnungen für Bestellung der Ersatzteile / Drawing assemblies for spare parts order**

- Při objednávání náhradních dílů vždy uvádějte: typ stroje (např. AL 400) , výrobní číslo (např. 125) a rok výroby (např. 1999).
- In die Bestellung der Ersatzteile führen Sie immer an: Maschinentyp (z. B. AL 400), Serien Nr. (z. B. 125) und Baujahr (z. B. 1999).
- For spare parts order, you must always to allege: type of machine (for example AL 400), serial number (for example 125, see cover page) and year of construction (for example 1999).
- Položky označené (Optional) - volitelné příslušenství/
Einträge markiert mit (Optional) - optionale Zubehör/
tems marked with (Optional) - optional accessories

6.1. ALU 400 SEMI

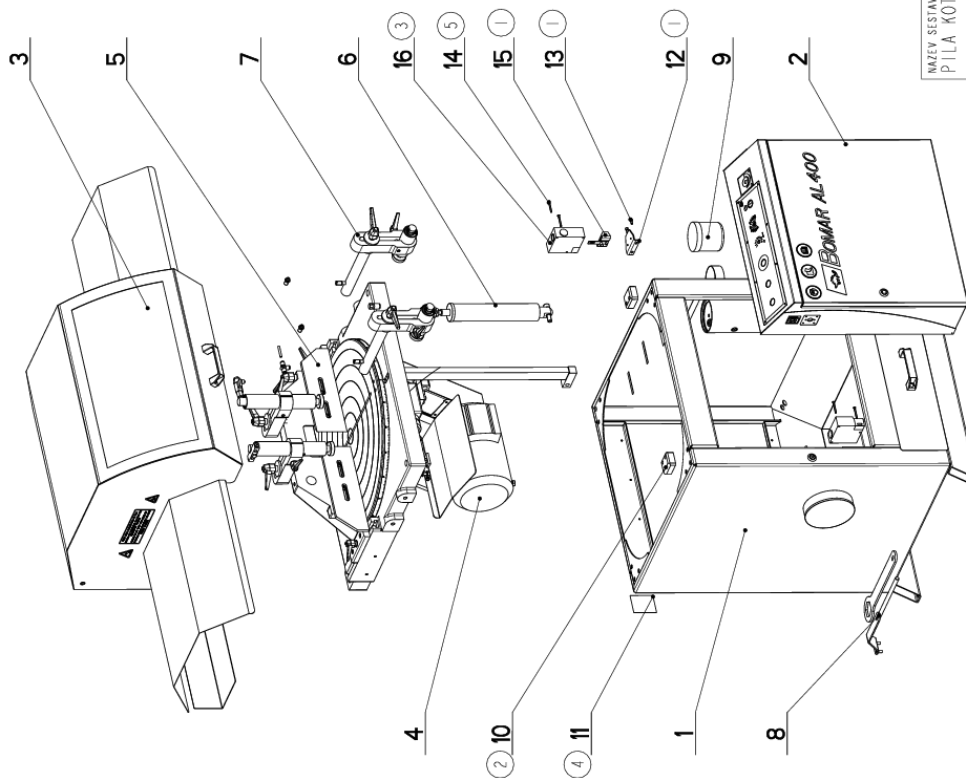

NAZEV SESTAVY PILA KOTOUČOVÁ	CÍSLO SESTAVY 201.K100-100	STROJ AL 400
Konstruoval: HERALT		
Datum: 05. 09. 2018		
Meritko: 2:25		

6.2. Kusovník / Piece list / Stückliste - ALU 400 SEMI

Císlo Sestavy		Verf.		Název sestavy	
201.K100-100		5		PILA KOTOUČOVÁ/ROTARY SAW/KREISSÄGE	
Pos.	Objednací číslo	Verf.	Název položky	Rožmer	Ks
1	201.K101-100	4	PODSTAVEC / BASE / UNTERSATZ		1
2	201.K101-220	5	ROZVADEC / DISTRIBUTOR / VERTEILER		1
3	201.K101-500	7	KRYT / COVER / ABDECKUNG		1
4	201.K102-000	7	RAMENO / SHOULDER / SÄGERAHMEN		1
5	201.K103-000	10	STUL / TABLE / TISCH		1
6	201.K107-000	4	VALEC ZVEDACI / LIFTING CYLINDER / HEBEZYLINDER		1
7	201.K114-000	4	UPINANI HORNÍ / TOP CLAM / SPANNVORRICHTUNG OBEN		1
8	201.K114-100	0	KLIC / KEY / SCHLÜSSEL		1
9	201.K116-000	6	PNEUMATIKA / TYRE / PNEUMATIK		1
10	30.K103-036	0	KOSTKA / CUBE / WÜRFEL	HR 50x60	2
11	30.K199-101	4	STITEK TYPOVÝ / MACHINE LABEL / MASCHINE SCHILD	P 0,5-65	1
12	30.K303-012	1	DRŽAK / HOLDER / HALTER	P 3x70	1
13	90.001.25.008	0	SROUB IMBUS / ALLEN HEAD BOLT / IMBUSSCHRAUBE	M5x12	2
14	90.013.92.111	5	SROUB PULKULATÝ / HALF ROUND BOLT / HALBRUNDSCHRAUBE	M4x40	5
15	91.173.039	0	ZAMEK / LOCK / SCHLOSS	XCS 713	1
16	91.173.040	0	SPINAC KONCOVÝ / END SWITCH / ENDSCHALTER	D4NL-4HFA-B	2
17	99.900.039	0	SAMOLEPKA / STICKER / AUFLEBER	NEBEZP.STLACENI	2
18	99.900.040	0	SAMOLEPKA / STICKER / AUFLEBER		2
19	99.900.046	0	SAMOLEPKA / STICKER / AUFLEBER		1
20	99.900.047	0	SAMOLEPKA / STICKER / AUFLEBER		1
21	99.900.048	0	SAMOLEPKA / STICKER / AUFLEBER		1
22	99.900.049	0	SAMOLEPKA / STICKER / AUFLEBER		1
23	99.900.066	0	SAMOLEPKA / STICKER / AUFLEBER	NEVKLADAT RUCE	2
24	99.901.008	0	SAMOLEPKA / STICKER / AUFLEBER	AL400	1

1. PRID. DRŽAK 30.K303-012, KOSTKA 30.K303-036, ZAMEK 91.173.039, SPINAC KONCOVÝ 91.173.040, SROUB M5x12 90.001.25.008, SAMOLEPKY 99.900.039, 99.900.040, 99.900.046, 259/ZM257 29.9.2010 SLEZACKOVA

2. VYMENEN DIL KOSTKA 30.K303-036 ZA DIL KOSTKA 30.K103-036. 305/ZM299 19.11.2010 HERALT

3. PRID. 1xKONCOVY SPINAC 91.173.040. 151/ZM190 1.9.2011 SLEZACKOVA

4. ZRUSEN STITEK 31.K199-101 A NAHR. 30.K199-101. 095/ZM251 20.7.2017 SLEZACKOVA

5. PRID. 5xSROUB M4x40 90.013.92.111. 171/ZM311 5.9.2018 SZABARI

Císlo Sestavy/Number of assembly/Nummer der Baugruppe; Verf. (Ver./Version/Version); Název sestavy/Assembly title/Name der Baugruppe; Pozice (Pos./Position/Position);
Objednací číslo/Purchase order number/Bestellnummer; Název položky/Volume title/Name der Position; Rožmer/Stock size/Abmessung

6.3. ALU 400 SEMI

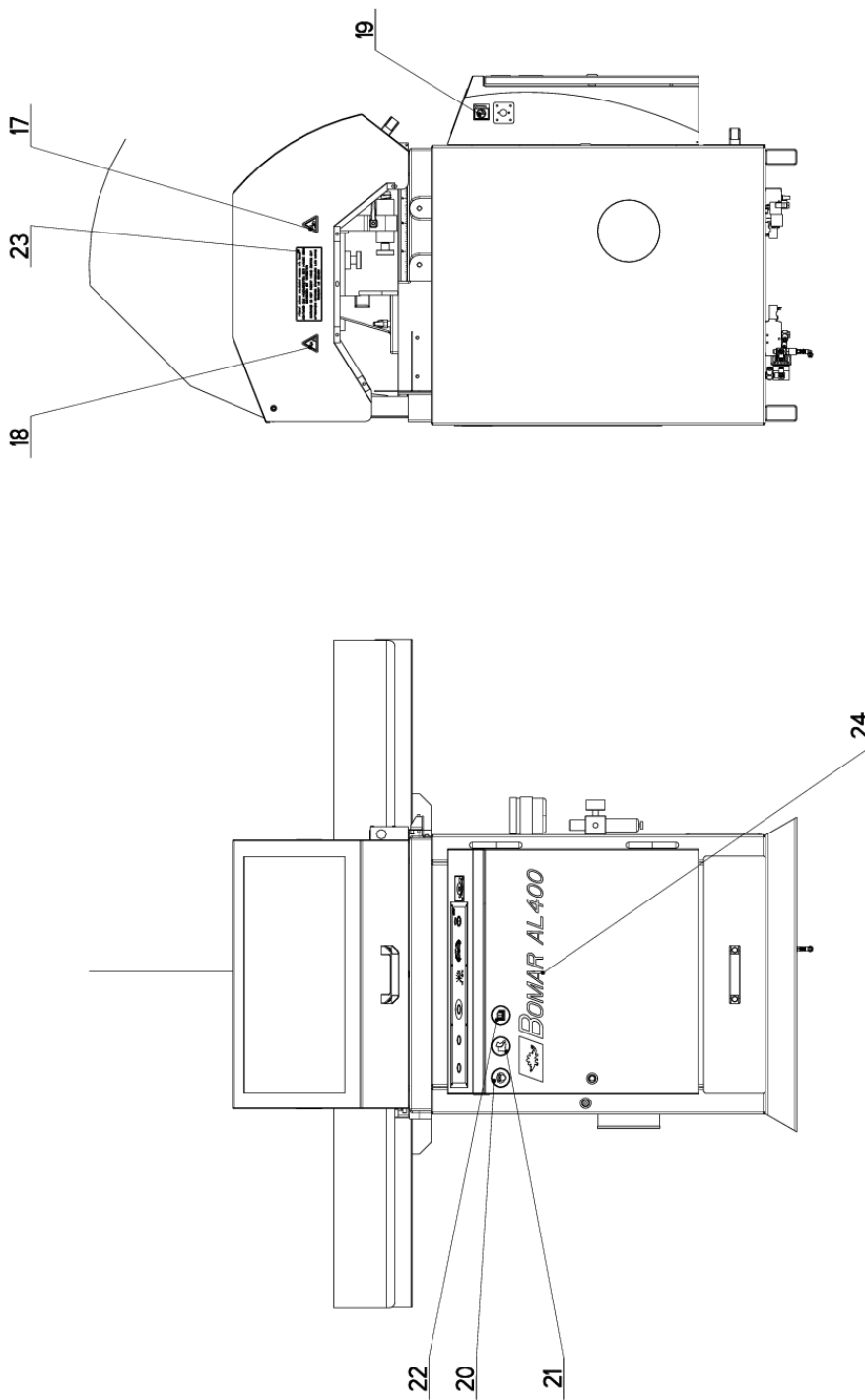

NAZEV SESTAVY PILA KOTOUČOVÁ	CÍSLO SESTAVY 201_K100-100	STROJ AL 400
Konstruoval: HERALT		
Datum: 05. 09. 2018		
Meritko: 1:10		

6.4. Kusovník / Piece list / Stückliste - ALU 400 SEMI

Císlo Sestavy		Verf.		Název sestavy	
201.K100-100		5		PILA KOTOUČOVÁ/ROTARY SAW/KREISSÄGE	
Pos.	Objednací číslo	Verf.	Název položky	Rozměr	Ks
1	201.K101-100	4	PODSTAVEC / BASE / UNTERSATZ		1
2	201.K101-220	5	ROZVADEC / DISTRIBUTOR / VERTEILER		1
3	201.K101-500	7	KRYT / COVER / ABDECKUNG		1
4	201.K102-000	7	RAMENO / SHOULDER / SÄGERAHMEN		1
5	201.K103-000	10	STUHL / TABLE / TISCH		1
6	201.K107-000	4	VALEC ZVEDACÍ / LIFTING CYLINDER / HEBEZYLINDER		1
7	201.K114-000	4	UPINANI HORNÍ / TOP CLAM / SPANNVORRICHTUNG OBEN		1
8	201.K114-100	0	KLIC / KEY / SCHLÜSSEL		1
9	201.K116-000	6	PNEUMATIKA / TYRE / PNEUMATIK		1
10	30.K103-036	0	KOSTKA / CUBE / WÜRFEL	HR 50x60	2
11	30.K199-101	4	STITEK TYPOVÝ / MACHINE LABEL / MASCHINE SCHILD	P 0,5-65	1
12	30.K303-012	1	DRŽAK / HOLDER / HALTER	P 3x70	1
13	90.001.25.008	0	SROUB IMBUS / ALLEN HEAD BOLT / IMBUSSCHRAUBE	M5x12	2
14	90.013.92.111	0	SROUB PULKULATÝ / HALF ROUND BOLT / HALBRUNDSCHRAUBE	M4x40	5
15	91.173.039	0	ZAMEK / LOCK / SCHLOSS	XCS 713	1
16	91.173.040	0	SPINAC KONCOVÝ / END SWITCH / ENDSCHALTER	D4NL-4HFA-B	2
17	99.900.039	0	SAMOLEPKA / STICKER / AUFLEBER	NEBEZP.STLACENI	2
18	99.900.040	0	SAMOLEPKA / STICKER / AUFLEBER		2
19	99.900.046	0	SAMOLEPKA / STICKER / AUFLEBER		1
20	99.900.047	0	SAMOLEPKA / STICKER / AUFLEBER		1
21	99.900.048	0	SAMOLEPKA / STICKER / AUFLEBER		1
22	99.900.049	0	SAMOLEPKA / STICKER / AUFLEBER		1
23	99.900.066	0	SAMOLEPKA / STICKER / AUFLEBER	NEVKLADAT RUCE	2
24	99.901.008	0	SAMOLEPKA / STICKER / AUFLEBER	AL400	1

1. PRID. DRŽAK 30.K303-012, KOSTKA 30.K303-036, ZAMEK 91.173.039, SPINAC KONCOVÝ 91.173.040, SROUB M5x12 90.001.25.008, SAMOLEPKY 99.900.039, 99.900.040, 99.900.046, 259/ZM257 29.9.2010 SLEZACKOVA

2. VYMENEN DIL KOSTKA 30.K303-036 ZA DIL KOSTKA 30.K103-036. 305/ZM299 19.11.2010 HERALT

3. PRID. 1xKONCOVY SPINAC 91.173.040. 151/ZM190 1.9.2011 SLEZACKOVA

4. ZRUSEN STITEK 31.K199-101 A NAHR. 30.K199-101. 095/ZM251 20.7.2017 SLEZACKOVA

5. PRID. 5xSROUB M4x40 90.013.92.111. 171/ZM311 5.9.2018 SZABARI

Císlo Sestavy/Number of assembly/Nummer der Baugruppe; Verf. (Ver./Version/Version); Název sestavy/Assembly title/Name der Baugruppe; Pezice (Pos./Position/Position);
Objednací číslo/Purchase order number/Bestellnummer; Název položky/Volume title/Name der Position; Rozměr/Stock size/Abmessung

6.5. Podstavec / Base / Untersatz

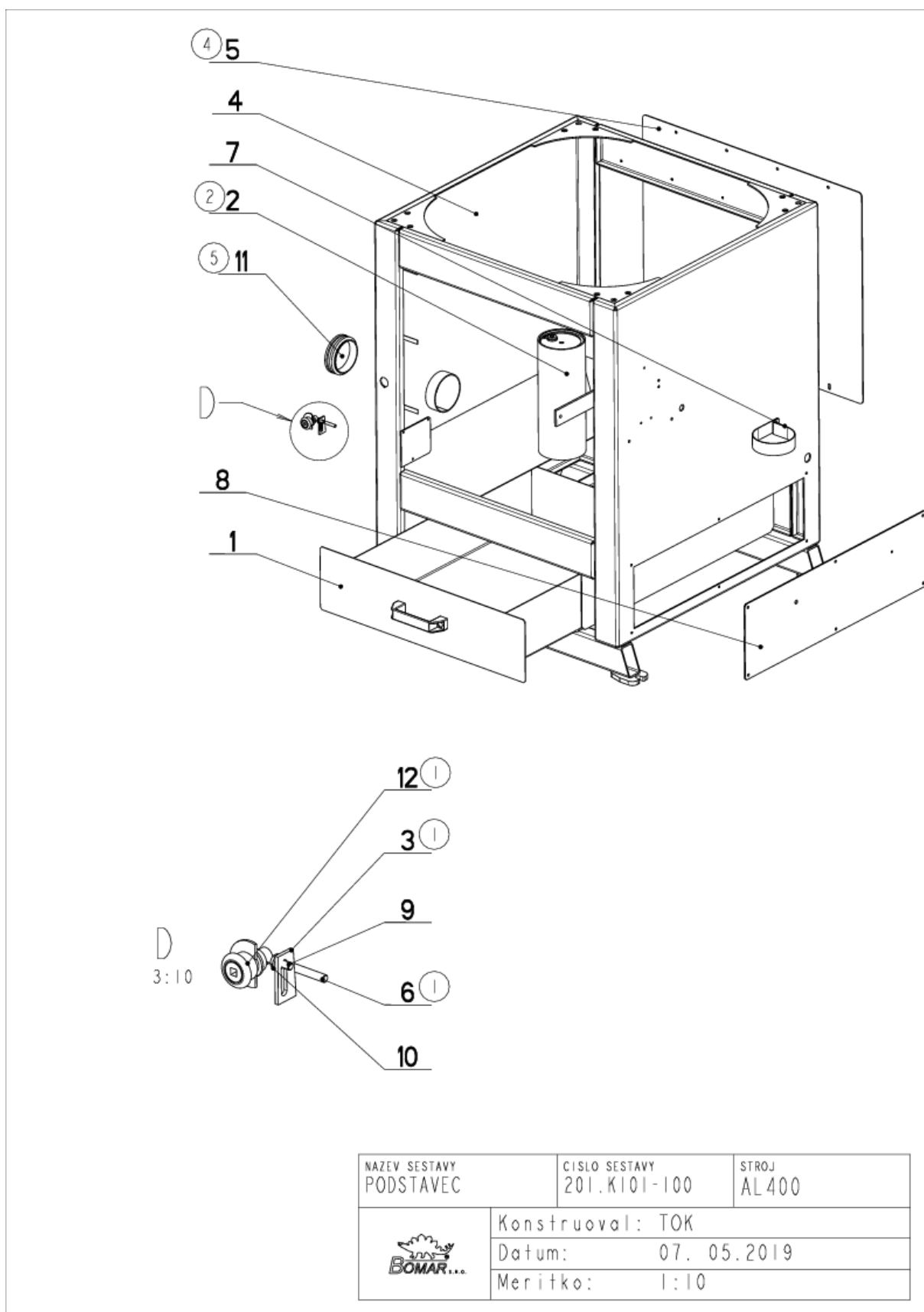

NAZEV SESTAVY PODSTAVEC	CISLO SESTAVY 201.K101-100	STROJ AL400
	Konstruoval: TOK	
	Datum: 07. 05.2019	
	Meritko: 1:10	

6.6. Kusovník / Piece list / Stückliste - Podstavec / Base / Untersatz

Císlo Sestavy 201.K101-100		Ver. 5		Název sestavy PODSTAVEC/BASE/UNTERSATZ	
Poz.	Objednávací číslo	Ver.	Název položky	Rozměr	Ks
1	201.K101-145	0	VANA / TANK / WANNE		1
2	201.K107-300 (2)	1	VALEC / ROLLER / ZYLINDER		1
3	30.K100-111 (1)	0	DRŽAK / HOLDER / HALTER	P 3x22	1
4	30.K101-101	7	PODSTAVEC / BASE / UNTERSATZ		1
5	30.K101-109 (4)	0	KRYT / COVER / ABDECKUNG	P2x531	1
6	30.K101-154 (1)	0	TYC / POLE / STANGE	D 6	1
7	30.K103-023	0	DRŽAK / HOLDER / HALTER	P1.5x30	1
8	30.K107-112	2	KRYT / COVER / ABDECKUNG	P 3x190	1
9	90.005.55.006	0	SROUB 6HRANNÝ / 6 SIDED BOLT / SECHSKANTSCHRAUBE	SROUB M6X12	1
10	90.150.50.004	0	PODLOŽKA / WASHER / UNTERLEGSCHIBE	PODLOŽKA 6,4	1
11	94.100.021 (5)	0	ZATKA / PLUG / STOPFEN	D 90	1
12	99.104.004 (1)	0	ZAMEK ROZVADECOVÝ / DISTRIBUTOR LOCK / VERTEILERSCHLOSS	LK3	1

1. ZRUSEN ZAMEK 91.990.001 A NAHRÁZEN 99.104.004, PRIDANÝ SOUCASTI 30.K101-154, 30.K100-111 A 94.100.020 026/ZM038 9.2.2010 TOK
2. ZRUS. SOUCAST 201.K107-300 A NAHR. 30.K107-300. 048/ZM148 24.5.2010 SLEZACKOVA
3. ZRUSENA ZATKA 94.100.020; NAHREZENA ZATKOU 94.101.042; 300/zm.338 HLADIL 3.1.2012
4. PRIDAN KRYT 30.K101-109; 64/zm.78 22.3.2016 HLADIL
5. ZRUS. ZATKA 94.101.042 A NAHR. 94.100.021. 110/ZM158 7.5.2019 SZABARI

Císlo Sestavy/Number of assembly/Nummer der Baugruppe; Verze (Ver./Version/Version; Název sestavy/Assembly title/Name der Baugruppe; Pozice (Poz./)Position/Position;
Objednávací číslo/Purchase order number/Bestellnummer; Název položky/Volume title/Name der Position; Rozměr/Stock size/Abmessung

6.7. Vana / Tank / Wanne

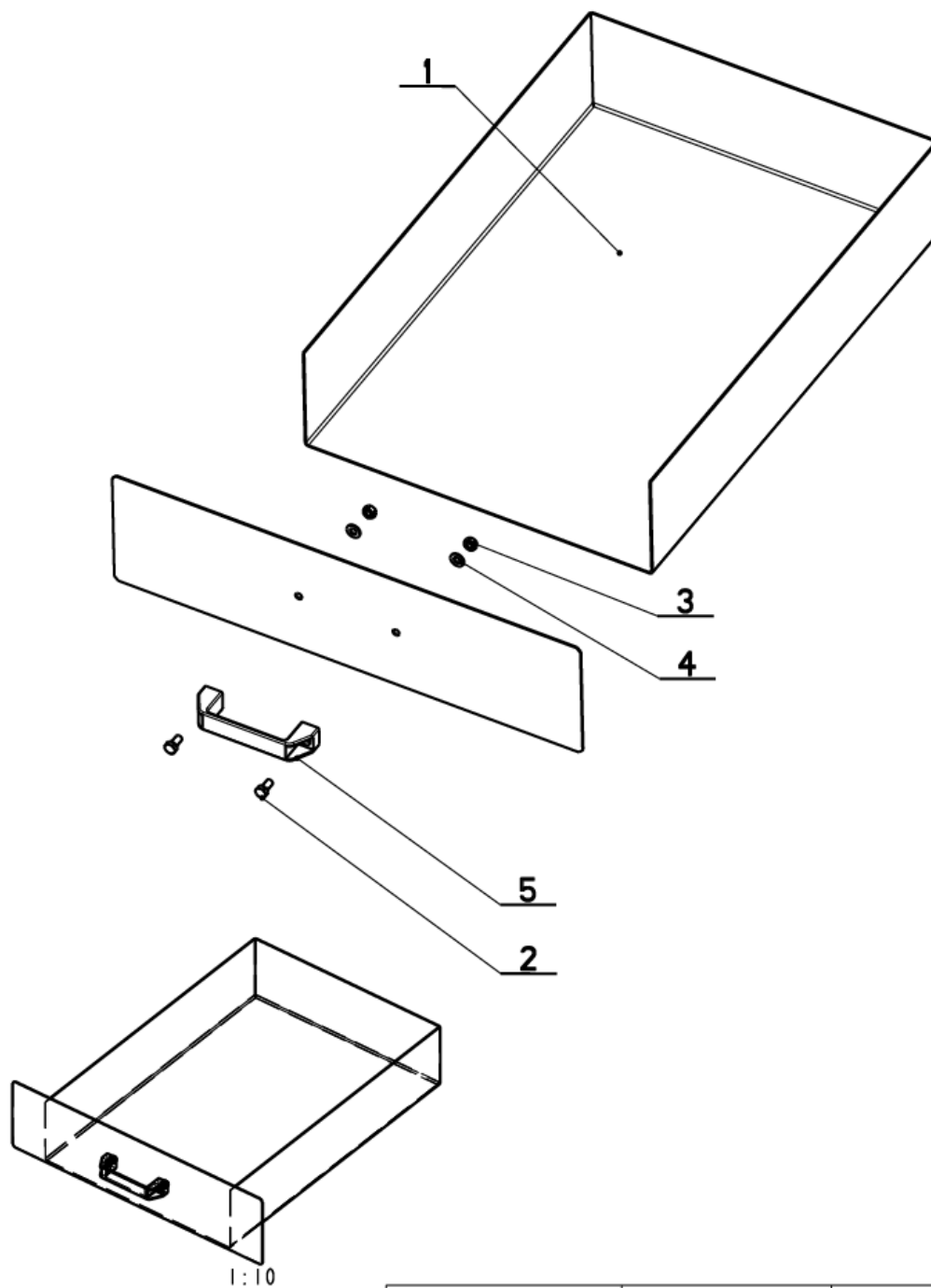

NAZEV SESTAVY VANA	CISLO SESTAVY 201.K101-145	STROJ AL400
	Konstruoval: TOK	
	Datum: 16. 12.2009	
	Meritko: 17:100	

6.8. Kusovník / Piece list / Stückliste - Vana / Tank / Wanne

Císlo Sestavy 201.K101-145		Ver. 0		Název sestavy VANA/TANK/WANNE	
Por.	Objednací číslo	Ver.	Název položky	Rozměr	Ks
1	30.K101-144	0	VANA / TANK / WANNE		1
2	90.005.55.014	0	ŠROUB 6HRANNÝ / 6 SIDED BOLT / SECHSANTSCHRAUBE	ŠROUB M8x16	2
3	90.100.55.005	0	MATICE / NUT / MUTTER	MATICE - M8	2
4	90.150.50.005	0	PODLOŽKA / WASHER / UNTERLEGSCHLEIBE	PODLOŽKA B,4	2
5	94.012.001	0	RUKOJET / HANDLE / GRIF		1

Císlo Sestavy/Number of assembly/Nummer der Baugruppe; Verze (Ver.)/Version/Version; Název sestavy/Assembly title/Name der Baugruppe; Pozice (Pos.)/Position/Position;
Objednací číslo/Purchase order number/Bestellnummer; Název položky/Volume title/Name der Position; Rozměr/Stock size/Abmessung

6.9. Válec / Roller / Zylinder

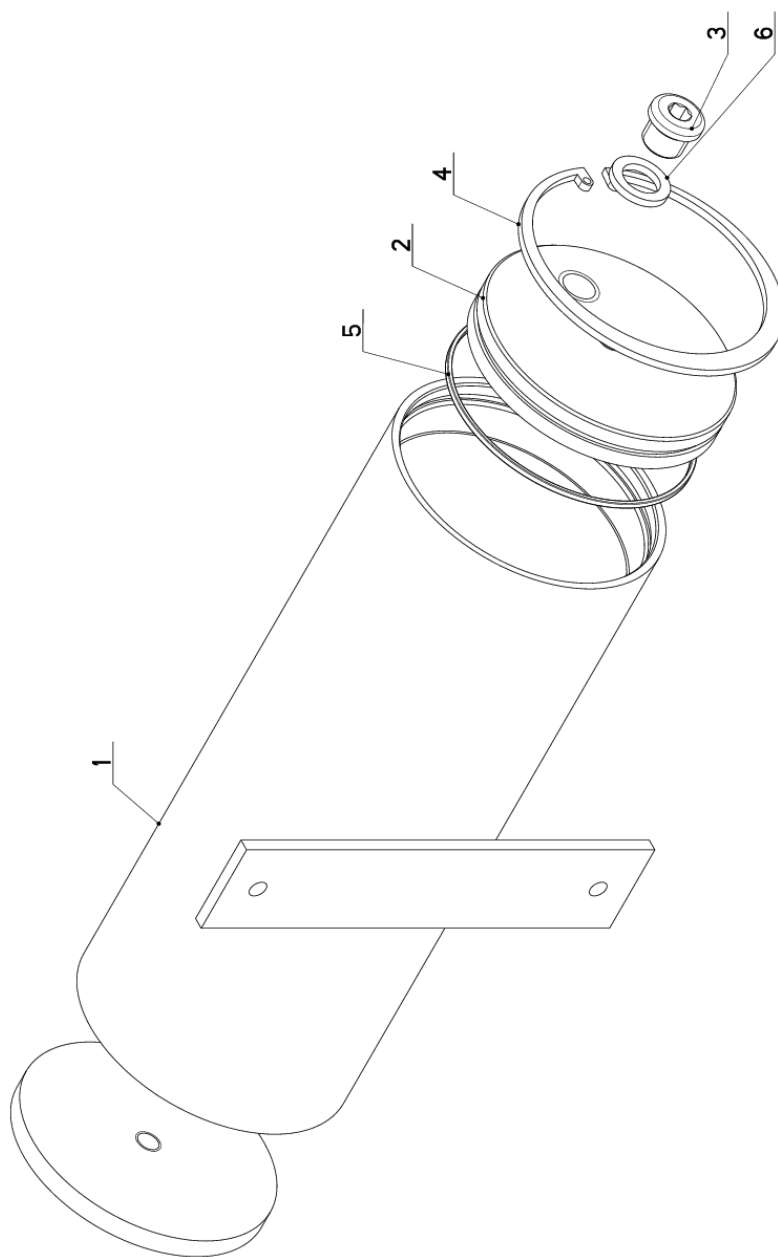

NAZEV SESTAVY VÁLEC	CÍSLO SESTAVY 201-K107-300	STROJ ALU 400
	Konstruoval: ZAJIC	Datum: 13. 04.2015
	Meritko: 1:2	

6.10. Kusovník / Piece list / Stückliste - Válec / Roller / Zylinder

Císlo Sestavy 201.K107-300		Ver. 1		Název sestavy VALEC/ROLLER/ZYLINDER	
Poz.	Objednávací číslo	Ver.	Název položky	Rožmer	Ks
1	30.K107-301	6	VALEC / CONTAINER / BEHÄLTER		1
2	30.K107-302	2	VÍKO / COVER / DECKEL	d 110	1
3	90.400.5Z.002	0	ZATKA / PLUG / STOPFEN	M16x1,5	1
4	95.801.031	0	SEGR DIRA / INSIDE SAFETY RING / SICHERUNGSRING INNEN	POJISTNY KROUZEK 100	1
5	96.002.022	0	KROUZEK O DYNAMICKY / DYNAMIC O RING / O-RING DYNAMISCH	95X2	1
6	96.081.001	0	KROUZEK TESNICI / SEAL RING / DICHTUNGSRING	23x15x3	1

1.ZRUS. 1x"0" KROUZEK 96.002.022, 1xPOJISTNY KROUZEK 95.801.031. 048/ZMI48 24.5.2010 SLEZACKOVA

Císlo Sestavy/Number of assembly/Nummer der Baugruppe; Verze (Ver./Version/Version); Název sestavy/Assembly title/Name der Baugruppe; Pozice (Pos./Position/Position);
Objednávací číslo/Purchase order number/Bestellnummer; Název položky/Volume title/Name der Position; Rožmer/Stock size/Abmessung

6.11. Rozvaděč / Distributor / Verteiler

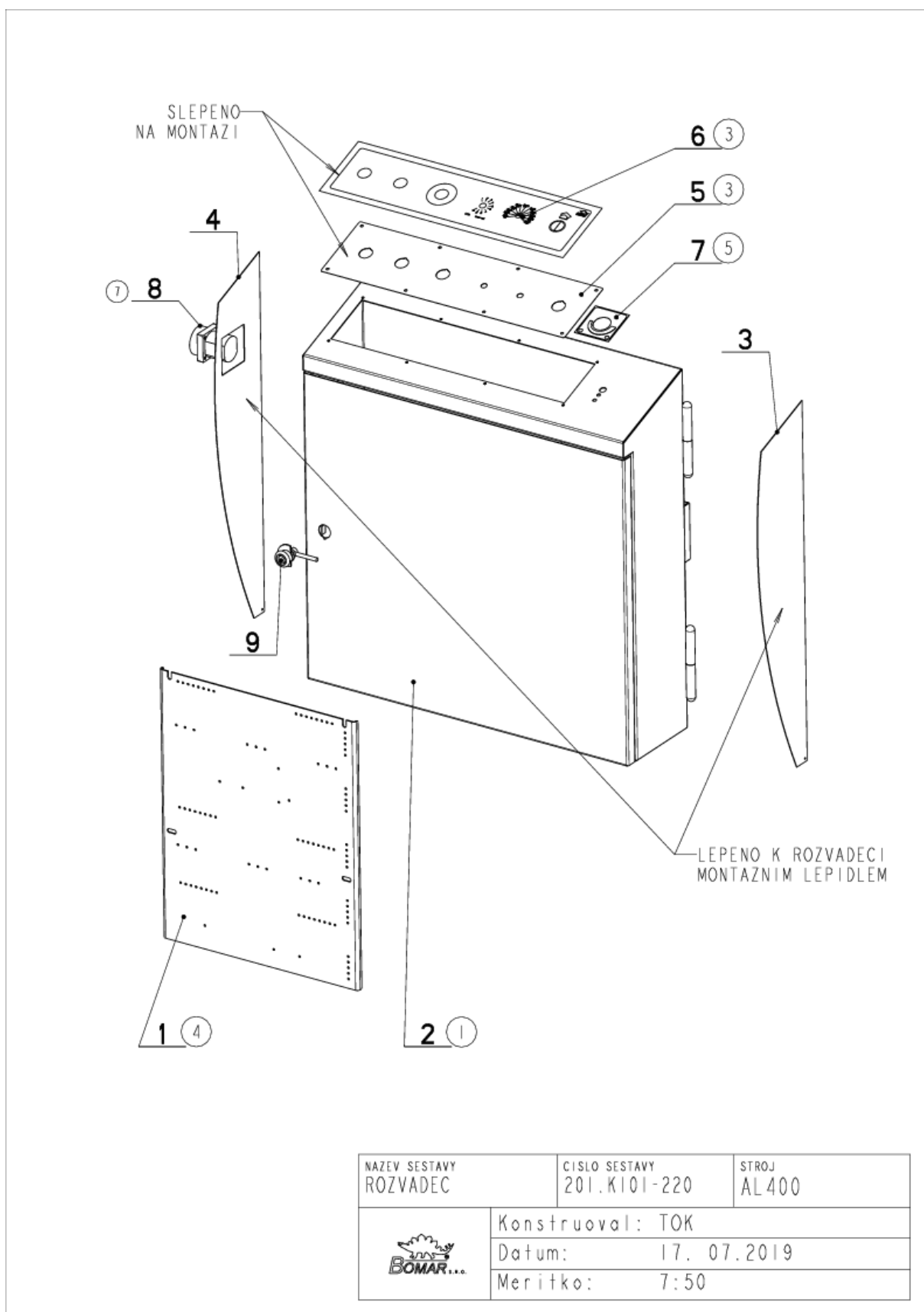

NAZEV SESTAVY ROZVADEC	CISLO SESTAVY 201.K101-220	STROJ AL400
	Konstruoval: TOK	
	Datum: 17. 07.2019	
	Meritko: 7:50	

6.12. Kusovník / Piece list / Stückliste - Rozvaděč / Distributor / Verteiler

Císlo Sestavy 201.K101-220		Ver. 7	Název sestavy ROZVADEČ/DISTRIBUTOR/VERTEILER		
Poz.	Objednávací číslo	Ver.	Název položky	Rozměr	Ks
1	30.K101-214 (4)	2	DESKA ELEKTRO / ELECTRIC BOARD / PLATINE	P2x480	1
2	30.K101-221 (1)	3	ROZVADEČ / DISTRIBUTOR / VERTEILER		1
3	30.K101-230	1	PLECH / STICKER / AUFKLEBER	P 1-134	1
4	30.K101-231	3	PLECH / PLATE / BLECH	P 1x134	1
5	30.K301-212 (3)	0	PANEL / PANEL / PANEL	P 2x123	1
6	31.K101-225 (3)	0	SAMOLEPKA / STICKER / AUFLEBER		1
7	31.K199-001 (5)	0	STÍTEK / LABEL / SCHILD	P 0.5x66	1
8	91.170.028 (7)	0	VYPINAC / SWITCH / SCHALTER	VYPINAC	1
9	91.990.001	0	ZAMEK ROZVADECOVY / DISTRIBUTOR LOCK / VERTEILERSCHLOSS		1
1. ZRUS. ROZVADEČ 31.K101-222 A NAHR. 30.K101-221. 021/ZM032 5.2.2010 SLEZACKOVA					
2. ZRUSEN PANT 30.K101-209, 30.K101-208. 090/ZM162 31.5.2010 SLEZACKOVA					
3. ZRUS. PANEL 30.K101-212 A NAHR. 30.K301-212, ZRUS. PANEL 30.K101-206 A NAHR. SAMOLEPKOU 31.K101-225. 322/ZM341 16.12.2010 SLEZACKOVA					
4. ZRUSEN PLECH 30.K101-207 A NAHR. 30.K101-214. 058/ZM082 24.3.2014 SLEZACKOVA					
5. PRIDAN 1xSTÍTEK 31.K199-001. 103/ZM117 30.5.2014 SLEZACKOVA					
6. PRIDAN 1xVYPINAC 91.170.029; 009/ZM193 7.5.2019 SCERBA					
7. ZRUS. VYPINAC 91.170.029 A NAHR. 91.170.028. 009/ZM295 17.7.2019 SZABARI					

Císlo Sestavy/Number of assembly/Nummer der Baugruppe; Verze (Ver./Version/Version; Název sestavy/Assembly title/Name der Baugruppe; Pozice (Poz./)Position/Position;
Objednávací číslo/Purchase order number/Bestellnummer; Název položky/Volume title/Name der Position; Rozměr/Stock size/Abmessung

6.13. Kryt / Cover / Abdeckung

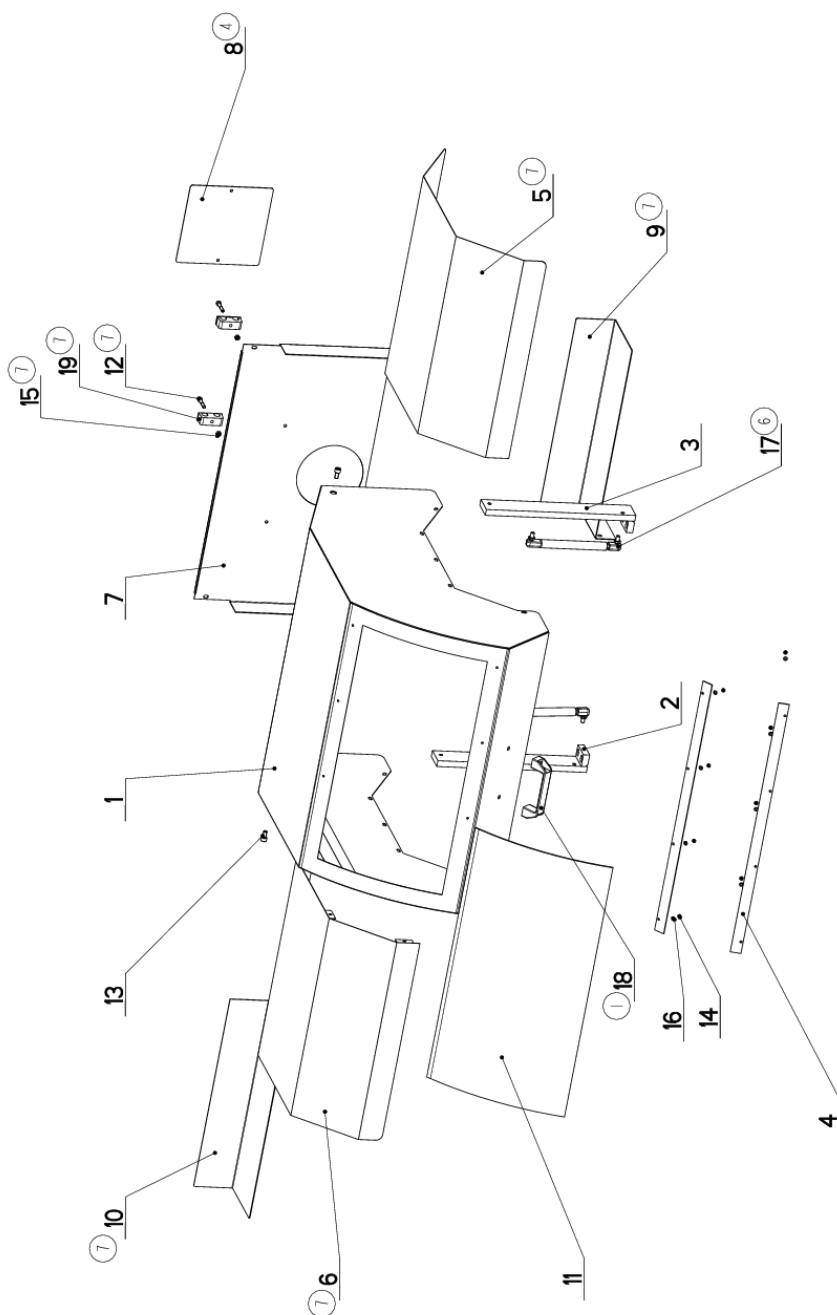

NAZEV ŠESTAVY KRYT	CISLO ŠESTAVY Z01.K101-500	STROJ ALU-400
	Konstruoval: VRSECKY	
	Datum: 07. 10. 2015	
	Meritko: 11:100	

6.14. Kusovník / Piece list / Stückliste - Kryt / Cover / Abdeckung

Císlo sestavy 201.K101-500		Ver. 7	Název sestavy KRYT/COVER/ABDECKUNG		
Poz.	Objednávací číslo	Ver.	Název položky	Rožmer	Ks
1	30.K101-501	1	KRYT / COVER / ABDECKUNG		1
2	30.K101-502	1	DRZAK / HOLDER / HALTER		1
3	30.K101-504	1	DRZAK / HOLDER / HALTER		1
4	30.K101-506	0	LISTA / TRIM / LEISTE	P 2x 25	2
5	30.K101-507	0	KRYT / COVER / ABDECKUNG		1
6	30.K101-508	0	KRYT / COVER / ABDECKUNG		1
7	30.K101-519	3	KRYT / COVER / ABDECKUNG	P 1,5x367	1
8	30.K101-526	0	KRYT / COVER / ABDECKUNG	P 1,5x200	1
9	30.K101-531	0	KRYT / /	P 1,5x245	1
10	30.K101-532	0	KRYT / /	P 1,5x245	1
11	31.K101-505	0	SKLO ORGANICKE / PLEXIGLASS / PLEXIGLAS	3x338	1
12	90.001.25.021	7	SROUB IMBUS / ALLEN HEAD BOLT / IMBUSSCHRAUBE	M6x35	2
13	90.001.25.031	0	SROUB IMBUS / ALLEN HEAD BOLT / IMBUSSCHRAUBE	8x16	2
14	90.100.55.002	0	MATICE / NUT / MUTTER	MATICE - M4	8
15	90.100.55.004	7	MATICE / NUT / MUTTER	MATICE - M6	2
16	90.150.30.002	0	PODLOZKA / WASHER / UNTERLEGSCHIEBE	PODLOZKA 4, 3	8
17	93.004.148	6	VZPERA PLYNOVA / GAS PROP / GASDRUCKFEDER	STABILUS 083488	2
18	94.012.001	1	RUKOJET / HANDLE / GRIFF		1
19	94.204.005	7	DRZAK / HOLDER / HALTER	LBG 147/14-PP	2

- ZM. PRIDANY POZ. 49.250.004,61.360.002,30.K101-512,POZ. 94.012.001 NAHRADILA POZ. 30.K101-509, 5.11.04 VRSECKY
- PRIDANO - PLECH 30.K101-601,GUMA 30.K101-602,ZRUS.KRYT 30.K101-508,30.K101-507, 259/ZM260 29.9.2010 SLEZACKOVA
- KRYT 30.K101-503 NAHRAZEN KRYTEM 30.K101-519; ZRUSENY KARTACKY 49.250.004 ,KRYT 30.K101-512, LEP PASKA 61.360.002
PRIDANA ZATKA 94.101.042; 303/zm.340 HLADIL 3.1.2012
- ZRUS.ZATKA 94.101.042 A NAHR.PLECHEM 30.K101-526. 147/ZM195 18.6.2012 SLEZACKOVA
- ZRUS.VZPERA PLYNOVA 93.004.006 A NAHR.93.004.108. 184/ZM300 12.10.2012 SLEZACKOVA
- ZRUS.PLYNOVA VZPERA 93.004.108 A NAHR.93.004.148 06Z/ZM082 SLEZACKOVA
- PRID.DRZAK KABELU 2x94.204.005,2xSROUB M6x35(90.001.25.021),2xMATICE M6(90.100.55.004),ZRUS.PLECH30.K101-601,
ZRUS.GUMA 30.K101-602,PRID.KRYTY 30.K101-507,30.K101-508,30.K101-531,30.K101-532 .03Z/ZM223 6.10.2015 SLEZACKOVA

Císlo Sestavy/Number of assembly/Nummer der Baugruppe; Verze (Ver./Version/Version; Název sestavy/Assembly title/Name der Baugruppe; Pozice (Pos./Position/Position;
Objednávací číslo/Purchase order number/Bestellnummer; Název položky/Volume title/Name der Position; Rožmer/Stock size/Abmessung

6.15. Rameno / Shoulder / Sägerahmen

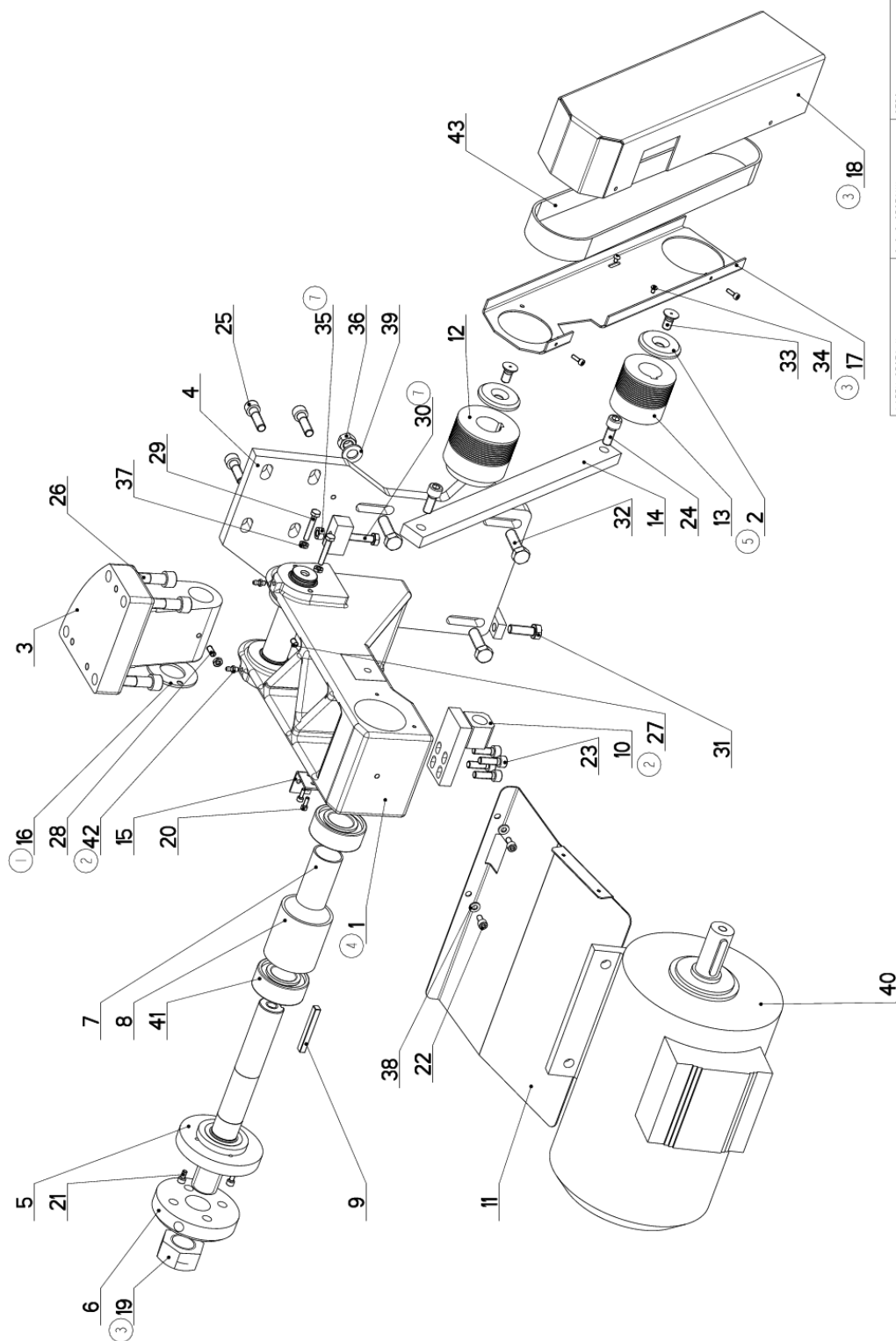

NAZEV SESTAVY RAMENO	CISLO SESTAVY 201.K102-000	STROJ ALU 400
		
Konstruoval: ZAJIC		
Datum: 11. 09. 2015		
Meritko: 1:4		

6.16. Kusovník / Piece list / Stückliste - Rameno / Shoulder / Sägerahmen

Císlo Sestavy 201. K102-000		Ver. 7		Název sestavy RAMENO/SHOULDER/SÄGERAHMEN	
Poz.	Objednací číslo	Ver.	Název položky	Rožmer	Ks
1	201. K102-050 (4)	0	KONZOLA / CONSOLE / KONSOLE		1
2	30. 2908-001 (5)	1	PODLOŽKA / WASHER / UNTERLEGSCHIEBE	d 50	2
3	30. K102-001	3	KONZOLA / CONSOLE / KONSOLE	ODLITEK	1
4	30. K102-003	3	DRŽAK / HOLDER / HALTER		1
5	30. K102-004	4	HRÍDEL / SHAFT / WELLE	d 100	1
6	30. K102-005	2	KOTOUČ / DISC / SCHEIBE	TYC 100	1
7	30. K102-006	1	DISTANC / DISTANCE / DISTANZ	TR 35x2	1
8	30. K102-007	1	DISTANC / DISTANCE / DISTANZ	TR 65x5	1
9	30. K102-009	0	PERO / SPRING / FEDER	8x7	1
10	30. K102-010	3	DRŽAK / HOLDER / HALTER		1
11	30. K102-011	4	KRYT MOTORU / MOTOR COVER / MOTORABDECKUNG	P 1.5x280	1
12	30. K102-017	1	REMENICE / PULLEY / RIEMENSCHIEBE	d 75	1
13	30. K102-018	1	REMENICE / PULLEY / RIEMENSCHIEBE	d 65	1
14	30. K102-021	1	VYZTUŽA / REINFORCEMENT / VERSTEIFUNG	HR 30x15	1
15	30. K102-022	2	DRŽAK / HOLDER / HALTER	P 2x25	1
16	30. K102-023 (1)	2	KROUZEK / RING / RING	VYPALEK	1
17	30. K102-026 (3)	1	KRYT REMENE / BELT COVER / RIEMENABDECKUNG	P 2x120	1
18	30. K102-027 (3)	0	KRYT REMENE / BELT COVER / RIEMENABDECKUNG	P 2x255	1
19	30. K102-028 (3)	0	MATICE / NUT / MUTTER	TYC 6HR 46	1
20	90. 001. 25. 003	0	SROUB IMBUS / ALLEN HEAD BOLT / IMBUSSCHRAUBE	M4X12	4
21	90. 001. 25. 007	0	SROUB IMBUS / ALLEN HEAD BOLT / IMBUSSCHRAUBE	M5X10	2
22	90. 001. 25. 016	0	SROUB IMBUS / ALLEN HEAD BOLT / IMBUSSCHRAUBE	M6X12	2
23	90. 001. 25. 033	0	SROUB IMBUS / ALLEN HEAD BOLT / IMBUSSCHRAUBE	8x25	4
24	90. 001. 25. 047	0	SROUB IMBUS / ALLEN HEAD BOLT / IMBUSSCHRAUBE	M10X25	2
25	90. 001. 25. 049	0	SROUB IMBUS / ALLEN HEAD BOLT / IMBUSSCHRAUBE	M10X35	4
26	90. 001. 25. 062	0	SROUB IMBUS / ALLEN HEAD BOLT / IMBUSSCHRAUBE	M12X50	4
27	90. 002. 20. 023 (2)	0	SROUB STAVECI / ADJUSTMENT BOLT / STELLSCHRAUBE	SROUB M6X10	1
28	90. 003. 20. 007	0	SROUB STAVECI / ADJUSTMENT BOLT / STELLSCHRAUBE	SROUB M6X16	1
29	90. 005. 55. 011	0	SROUB 6HRANNY / 6 SIDED BOLT / SECHSKANTSCHRAUBE	SROUB M6X35	2
30	90. 005. 55. 019 (7)	0	SROUB 6HRANNY / 6 SIDED BOLT / SECHSKANTSCHRAUBE	SROUB M8X40	1
31	90. 005. 55. 025	0	SROUB 6HRANNY / 6 SIDED BOLT / SECHSKANTSCHRAUBE	SROUB M10X30	1
32	90. 005. 55. 034	0	SROUB 6HRANNY / 6 SIDED BOLT / SECHSKANTSCHRAUBE	SROUB M12X40	4
33	90. 011. 27. 008	0	ZAPUSTNY IMBUS / COUNTERSINK BOLT / SENKSCHRAUBE	SROUB M10X20	2
34	90. 013. 27. 017	0	SROUB PULKULATY / HALF ROUND BOLT / HALBRUNDSCHRAUBE	M4x6	2

Císlo Sestavy/Number of assembly/Nummer der Baugruppe; Verze (Ver./Version/Version; Název sestavy/Assembly title/Name der Baugruppe; Pozice (Pos./Position/Position;
Objednací číslo/Purchase order number/Bestellnummer; Název položky/Volume title/Name der Position; Rožmer/Stock size/Abmessung

6.17. Rameno / Shoulder / Sägerahmen

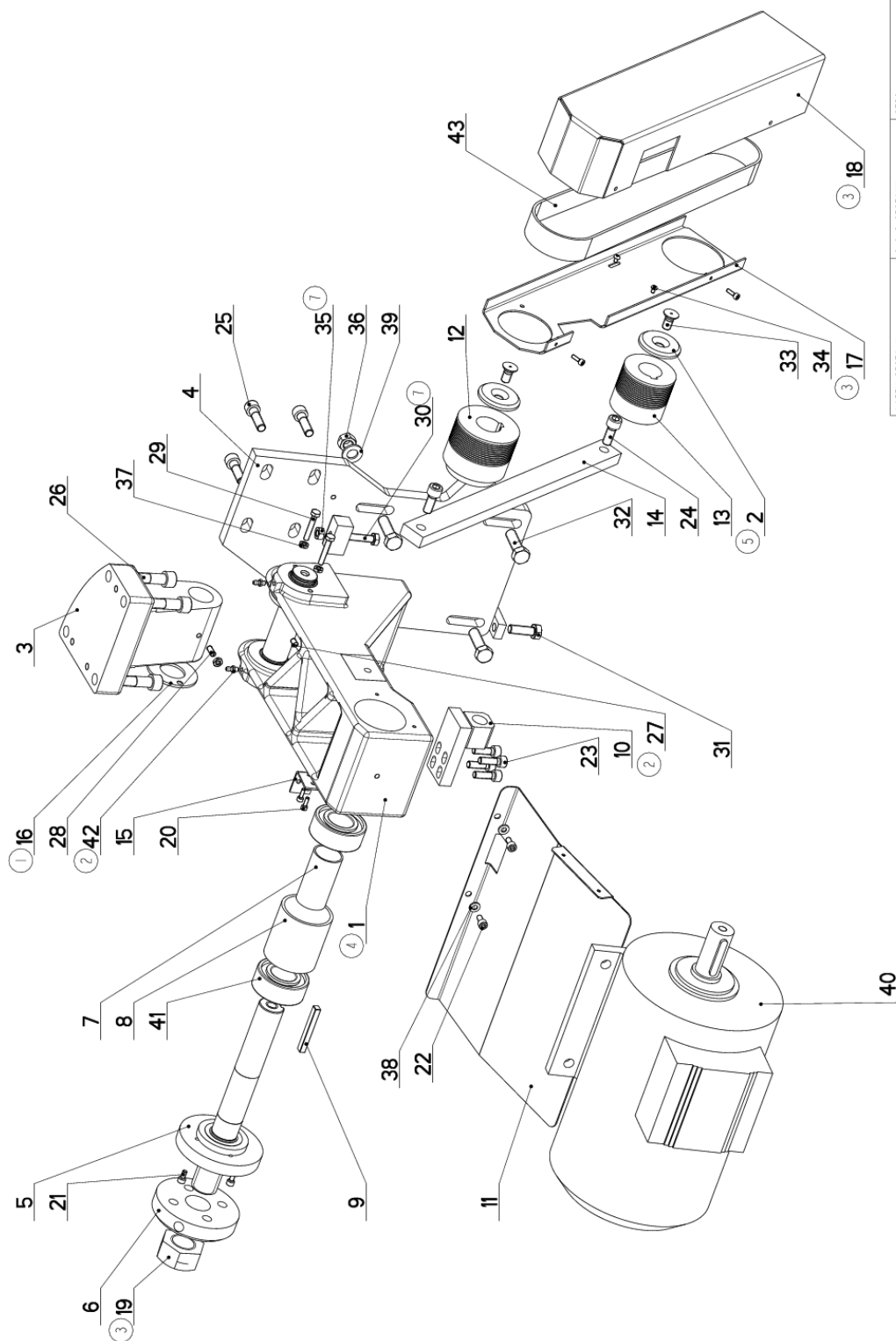

NAZEV SESTAVY RAMENO	CISLO SESTAVY 201.K102-000	STROJ ALU 400
		
Konstruoval: ZAJIC		
Datum: 11. 09. 2015		
Meritko: 1:4		

6.18. Kusovník / Piece list / Stückliste - Rameno / Shoulder / Sägerahmen

35	90.100.55.005	0	MATICE / NUT / MUTTER	MATICE - M8	1
36	90.100.55.007	0	MATICE / NUT / MUTTER	MATICE - M12	4
37	90.101.55.008	0	MATICE / NUT / MUTTER	MATICE M6	3
38	90.150.50.004	0	PODLOZKA / WASHER / UNTERLEGSCHIBE	PODLOZKA 6,4	2
39	90.150.50.007	0	PODLOZKA / WASHER / UNTERLEGSCHIBE	PODLOZKA 13	4
40	91.001.041	0	ELEKTROMOTOR / ELECTRIC MOTOR / ELEKTROMOTOR	3 kW	1
41	95.001.039	0	LOZISKO / BEARING / LAGER	5206-2RS	2
42	95.860.001	0	HLAVICE MAZACI / HEAD / KOPF	KM5	2
43	99.023.003	0	REMEN DRAZKOVY / GROOVED BELT / KEILRIPPENRIEMEN	12PJ	1

1. ZMENA NOVA SOUCAST 30.KI02-023 26.1.2004
2. ZM. PRIDANY SOCASTI POZ. 90.002.2D.023,95.860.001.16.12.04 VRSECKY
3. ZMENA NOVA SOUCAST 30.KI02-025, 30.KI02-026, 30.KI02-027, ZMENA DILU 90.100.25.001 NAHRADIL DIL 30.KI02-028
4.1.2006 RYSAVY
4. ZRUSENA SOUCAST 30.KI02-008, 30.KI02-002, 30.KI02-025, NOVA SOUCAST 201.KI02-050 20.4.2006 RYSAVY
5. ZRUS.PODLOZKA 30.1704-008 A NAHR.30.2908-001. 110/ZM112 27.6.2012 SLEZACKOVA
6. ZRUSEN DRZAK 30.KI02-020 A NAHR.30.KI02-029,ZRUS.SROUB M12x45(90.005.55.035) A NAHR.M10x45(90.005.55.027).
178/ZM209 2.10.2014 SLEZACKOVA
7. ZRUS.DRZAK 30.KI02-029,SROUB M10x45(90.005.55.027),PRID.1xSROUB M8x40(90.005.55.019),1xMATICE M8(90.100.55.005).
189/ZM211 11.9.2015 SLEZACKOVA

Cislo Sestavy/Number of assembly/Nummer der Baugruppe; Verze (Ver./Version/Version; Nazev sestavy/Assembly title/Name der Baugruppe; Pozice (Poz./Position/Position;
Objednac. cislo/Purchase order number/Bestellnummer; Mame polozky/Volume title/Name der Position; Rozmer/Stock size/Abmessung

6.19. Konzola / Console / Konsole

Cislo Sestavy 201. K102-050		Ver. 0	Nazev sestavy KONZOLA / CONSOLE / KONSOLE		
Poz.	Objednaci cislo	Ver.	Nazev polozky	Rozeber	Ks
1	30. K102-002	5	KONZOLA / CONSOLE / KONSOLE	ODLITEK	1
2	30. K102-025	1	POUZDRO / SLEEVE / BÜCHSE	d 36	2
3	30. K102-008	3	CEP / LUG / BOLZEN	d 32	1

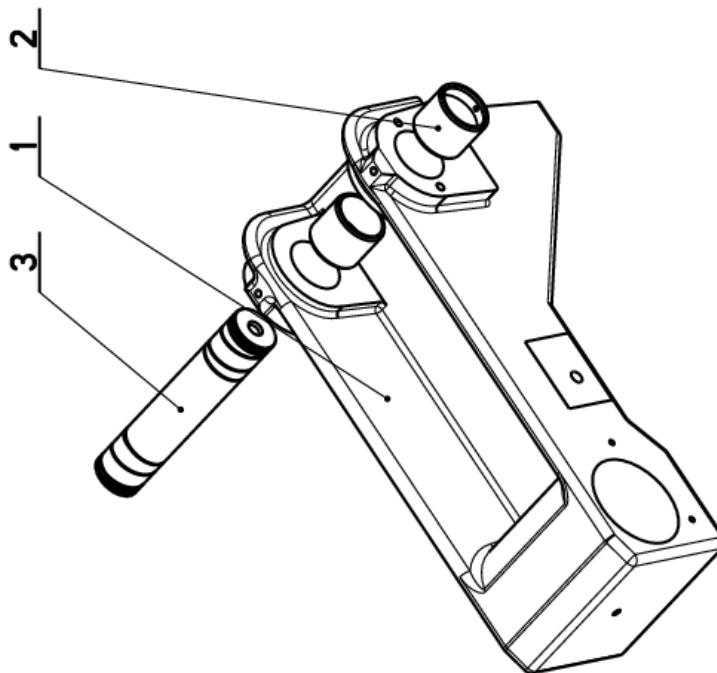

6.20. Stül / Table / Tisch

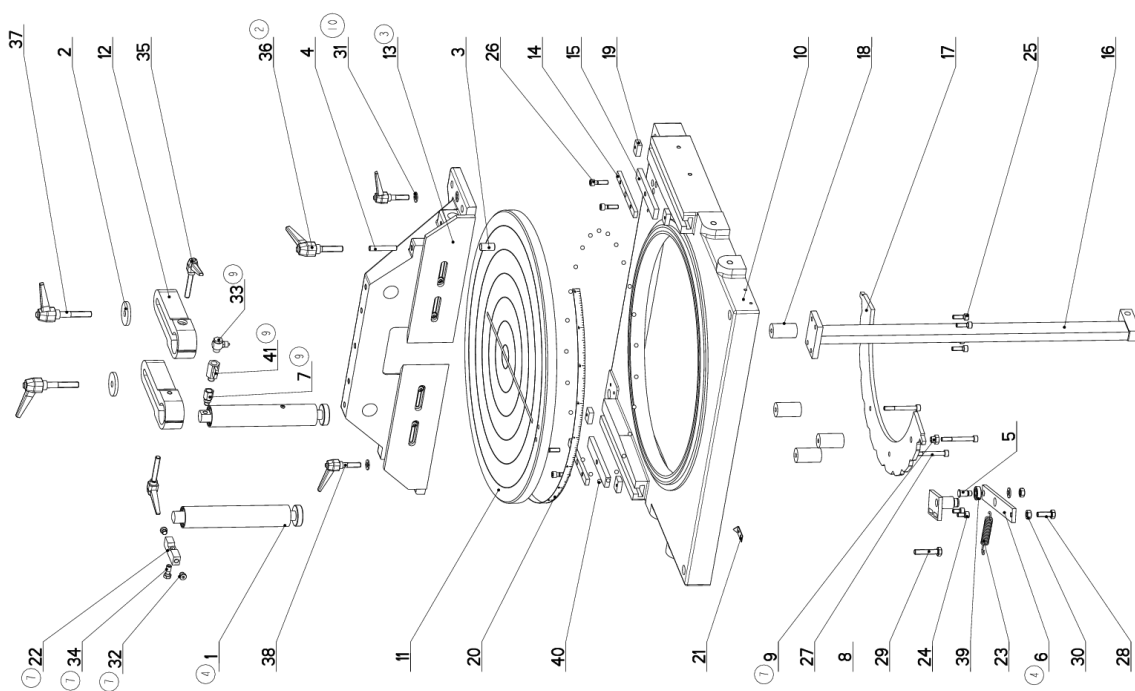

WAZU SERIYU STUL	CHISLO SERIYU 201.K103-000	STUOL ALU 400
Konstruoval: ZAJIC		
Datum: 27. 03. 2018		
Meritko: 17:100		

6.21. Kusovník / Piece list / Stückliste - Stůl / Table / Tisch

Císlo Sestavy 201.K103-000		Ver. 10		Název sestavy STUL/TABLE/TISCH	
Poz.	Objednací číslo	Ver.	Název položky	Rozměr	Ks
1	201.K107-100 (8)	0	VALEC UPÍNACÍ / FIXING CYLINDER / SPANNZYLINDER	P 6x50	2
2	30.0502-603	1	PODLOŽKA / WASHER / UNTERLEGSCHLEIBE	d15	2
3	30.0509-606	0	VALEČEK / CYLINDER / ROLLE	d10	1
4	30.0509-616	0	TYC / POLE / STANGE	d16	1
5	30.0802-011	0	CEP / LUG / BOLZEN	P 8x30	1
6	30.0802-013 (4)	1	PAKA / LEVER / HEBEL	TYC 17	1
7	30.3407-103 (9)	1	REDUCE / REDUCTION / ADAPTOR / REDUKTION	TYC 17	1
8	30.3509-013	3	CEP / LUG / BOLZEN	TYC 17	2
9	30.6804-102 (7)	2	EXCENTR / CAM / EXZENTER	TYC 17	2
10	30.K103-001	10	STUL / TABLE / TISCH		1
11	30.K103-002	7	STUL / TABLE / TISCH	ODLITEK	1
12	30.K103-004	2	DRŽAK / HOLDER / HALTER	ODLITEK	2
13	30.K103-005 (3)	0	CELIST PEVNÁ / SOLID JAW / FESTE BACKE	SESTAVA	1
14	30.K103-008	1	LISTA VODICI / LEAD TRIM / FÜHRUNGSLISTE	HR 15x8	2
15	30.K103-009	1	LISTA VODICI / LEAD TRIM / FÜHRUNGSLISTE	HR 25x10	2
16	30.K103-013	3	DRŽAK / HOLDER / HALTER	P 8x237	1
17	30.K103-015	5	SEGMENT / SEGMENT / SEGMENT	d30	1
18	30.K103-016	2	DISTANC / DISTANCE / DISTANZ	HR 20x10	4
19	30.K103-017	3	DORAZ / STOP PIECE / ANSCHLAG	P 0.5x15	4
20	30.K103-018	3	MERITKO / MEASURE / SKALA	PI 1x15	1
21	30.K103-024	0	UKAZATEL / INDICATOR / ZEIGER	HR 20x15	1
22	30.K107-417 (7)	0	KOSTKA ROZVADECI / DISTRIBUTION CUBE / VERTEILUNGSWÜRFEL	2.50x16x90x27	1
23	31.0206-005	0	PRUŽINA / SPRING / FEDER	8x16	1
24	90.001.25.031	0	SROUB IMBUS / ALLEN HEAD BOLT / IMBUSSCHRAUBE	8x25	2
25	90.001.25.033	0	SROUB IMBUS / ALLEN HEAD BOLT / IMBUSSCHRAUBE	M8X30	4
26	90.001.25.083	0	SROUB IMBUS / ALLEN HEAD BOLT / IMBUSSCHRAUBE	M8X70	4
27	90.001.25.095	0	SROUB IMBUS / ALLEN HEAD BOLT / IMBUSSCHRAUBE	SROUB M10X30	1
28	90.005.55.025	0	SROUB 6HRANNÝ / 6 SIDED BOLT / SECHSKANTSCHRAUBE	SROUB M10X50	1
29	90.005.55.028	0	SROUB 6HRANNÝ / 6 SIDED BOLT / SECHSKANTSCHRAUBE	MATICE - M10	2
30	90.100.55.006	0	MATICE / NUT / MUTTER	PODLOŽKA 10,5	3
31	90.150.50.006 (10)	0	PODLOŽKA / WASHER / UNTERLEGSCHLEIBE	G1/4" VNITRNI IMBUS	2
32	92.019.003	0	ZATKA / PLUG / STOPFEN	SROUBENI UHL. NATAČECI 1/4"-6/4	1
33	93.007.003 (9)	0	SROUBENI / BOLTING / VERSCHRAUBUNG	DUTY	1
34	93.010.001 (7)	0	SROUB / BOLT / SCHRAUBE		1

Císlo Sestavy/Number of assembly/Nummer der Baugruppe; Verze (Ver./Version/Version; Název sestavy/Assembly title/Name der Baugruppe; Pozice (Pos./Position/Position;
Objednací číslo/Purchase order number/Bestellnummer; Název položky/Volume title/Name der Position; Rozměr/Stock size/Abmessung

6.22. Stůl / Table / Tisch

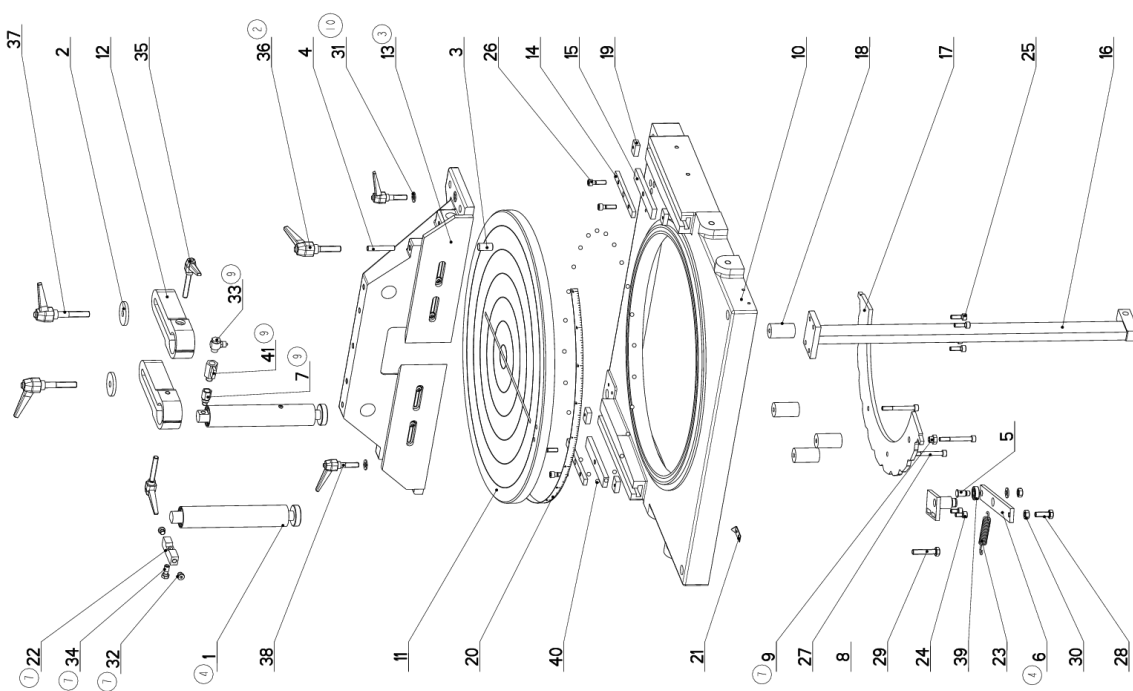

NAZEV ŠESTINY STŮL	ČÍSLO ŠESTINY 201.K103-000	ŠTŮL ALU 400
Konstruoval: ZAJIC		
Datum: 27. 03. 2018		
Verze: 17:100		

6.23. Kusovník / Piece list / Stückliste - Stůl / Table / Tisch

35	94.008.006	0	PAKA UPINACI / ATTACHMENT LEVER / SPANNHEBEL	M10	2
36	94.008.009	②	PAKA UPINACI / ATTACHMENT LEVER / SPANNHEBEL	M12	1
37	94.008.012	0	PAKA UPINACI / ATTACHMENT LEVER / SPANNHEBEL	M12x70	2
38	94.008.013	0	PAKA UPINACI / ATTACHMENT LEVER / SPANNHEBEL	M10	2
39	95.001.005	0	LOZISKO / BEARING / LAGER	6001 2RS	1
40	95.691.006	0	KOLECKO / WHEEL / ROLLE	RB 8	25
41	99.260.001	⑨	VENTIL / VALVE / VENTIL	VENTIL KULOVY	1

2. ZRUSENA SOUCAST 1x 94.008.013, NAHR. SOUCASTI 94.008.009, ZRUS. SOUCAST 30.K103-023, 7.4.2006 RYSAVY
3. ZRUSENY SOUCASTI 30.K103-003,30.K103-006,30.K103-007 A NAHR. SESTAVOU 30.K103-005. 329/ZM331 10.10.2008 SLEZACKOVA
4. ZRUS. SOUC. 30.0802-009 A NAHR. 30.0802-013. 167/ZM169 4.6.2010 SLEZACKOVA
6. VALCE 201.K107-100 NAHRAZENY VALCI 201.K107-400 19.8.2010 HLADIL 231/zm.230
7. PRIDAN 2xEXCENTR 30.6804-102; 30.K107-417; 93.010.001; 92.019.003; 235/ZM242 9.9.2010 SLEZACKOVA
8. VALCE 201.K107-400 NAHRAZENY VALCI 201.K107-100; 216/zm.252 HLADIL 16.9.2011
9. PRIDANO - REDUKCE 30.3407-103, SROUBENI 99.260.001, 93.007.003 . 256/ZM054 16.2.2012 SLEZACKOVA
10. PRIDANO - PODLOZKA 10,5 (90.150.50.006) POD MONTAZ. PAKU M10x40(94.008.013) 032/ZM094 14.3.2018 SZABARI

Cislo Sestavy/Number of assembly/Nummer der Baugruppe; Verze (Ver./Version/Version; Nazev sestavy/Assembly title/Name der Baugruppe; Pezice (Poz./Position/Position;
Objednacni cislo/Purchase order number/Bestellnummer; Mamez polozky/Volume title/Name der Position; Rozmer/Stock size/Abmessung

6.24. Válec upínací / Fixing cylinder / Spannzylinder

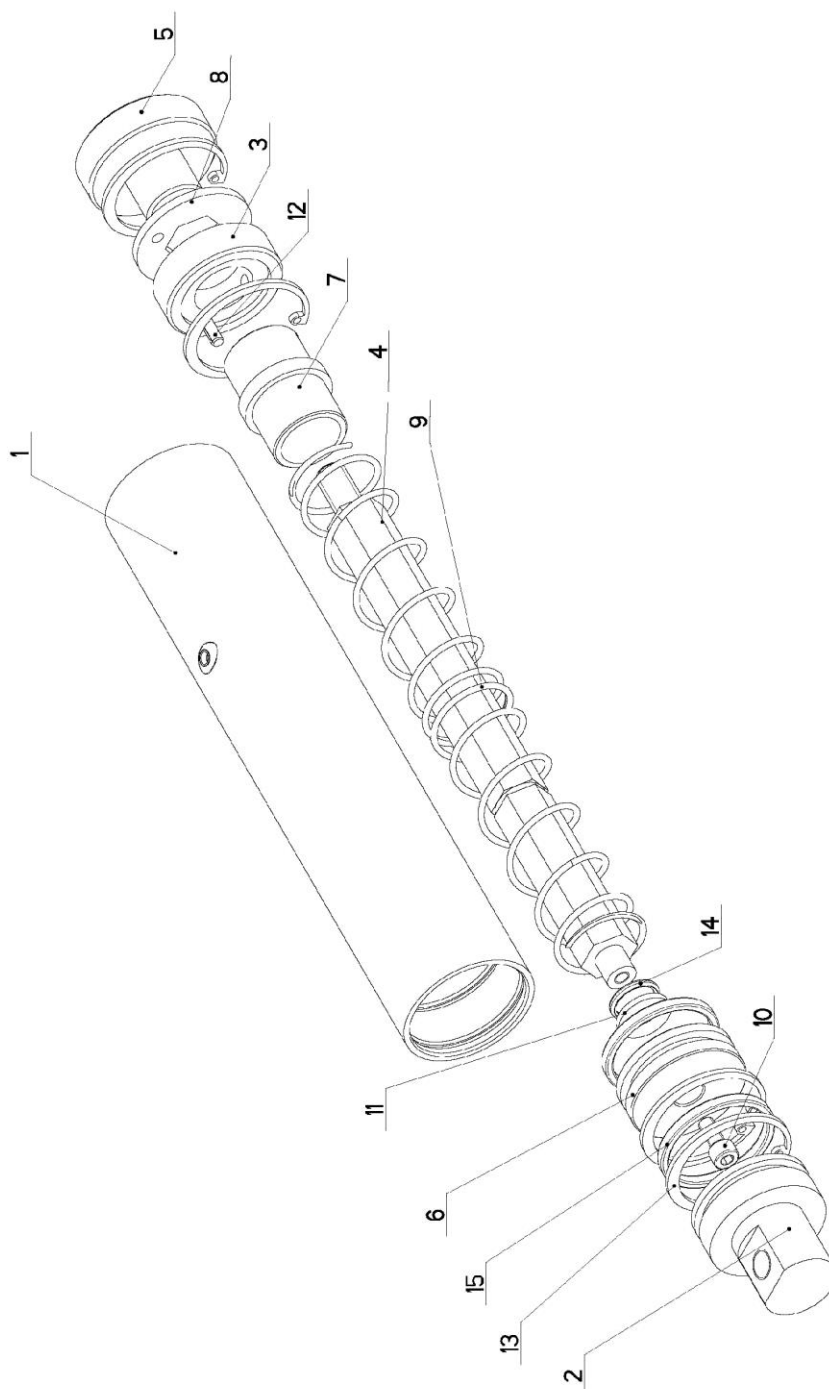

NAZEV SESTAVY VÁLEC UPÍNACÍ	ČÍSLO SESTAVY 201.K107-130	STROJ ALU 400
		
Konstruována : ZAJIC		
Datum: 13. 04. 2015		
Měřítko: 1:2		

6.25. Kusovník / Piece list / Stückliste - Válec upínací / Fixing cylinder / Spannzylinder

Číslo Sestavy 201.K107-100		Název sestavy VALEC UPÍNAČI / FIXING CYLINDER / SPANNZYLINDER			
Poz.	Objednací číslo	Ver.	Název položky	Rožmer	Ks
1	30.K107-101	2	VALEC UPÍNAČI / FIXING CYLINDER / SPANNZYLINDER	TR 45/40H8	1
2	30.K107-102	0	VÍKO / COVER / DECKEL	d 45	1
3	30.K107-103	1	VÍKO / COVER / DECKEL	d 45	1
4	30.K107-104	3	PISTNICE / PISTON ROD / KOLBENSTANGE	6HR-17	1
5	30.K107-105	1	DORAZ / STOP PIECE / ANSCHLAG	d 50	1
6	30.K107-106	3	PIST / PISTON / KOLBEN	d 45	1
7	30.K107-109	0	KROUZEK VODICI / LEAD RING / FÜHRUNGSRING	d 30	1
8	30.K107-111	2	KROUZEK VODICI / LEAD RING / FÜHRUNGSRING	d 40	1
9	31.K107-107	0	PRUŽINA / SPRING / FEDER	2x30x105x(5+2)	2
10	90.001.25.008	0	SROUB IMBUS / ALLEN HEAD BOLT / IMBUSSCHRAUBE	M5x12	1
11	90.151.50.006	0	PODLOŽKA / WASHER / UNTERLEGSCHIBE	PODLOŽKA 5	1
12	90.303.02.013	0	KOLÍK PRUŽNY / PIN / BOLZEN	KOLÍK 4x12	1
13	95.801.005	0	SEGR DIRA / INSIDE SAFETY RING / SICHERUNGSRING INNEN	POJISTNÝ KROUZEK 40	4
14	96.001.004	0	O-KROUZEK STATIC / STATIC O RING / O-RING STATISCH	10x2	1
15	96.002.017	0	KROUZEK O DYNAMICKY / DYNAMIC O RING / O-RING DYNAMISCH	34x3 NBR 70SH	2

Číslo Sestavy/Number of assembly/Nummer der Baugruppe; Verze (Ver./Version/Version); Název sestavy/Assembly title/Name der Baugruppe; Pozice (Pos./Position/Position);
Objednací číslo/Purchase order number/Bestellnummer; Název položky/Volume title/Name der Position; Rožmer/Stock size/Abmessung

6.26. Válec zvedací / Lifting cylinder / Hebezyylinder

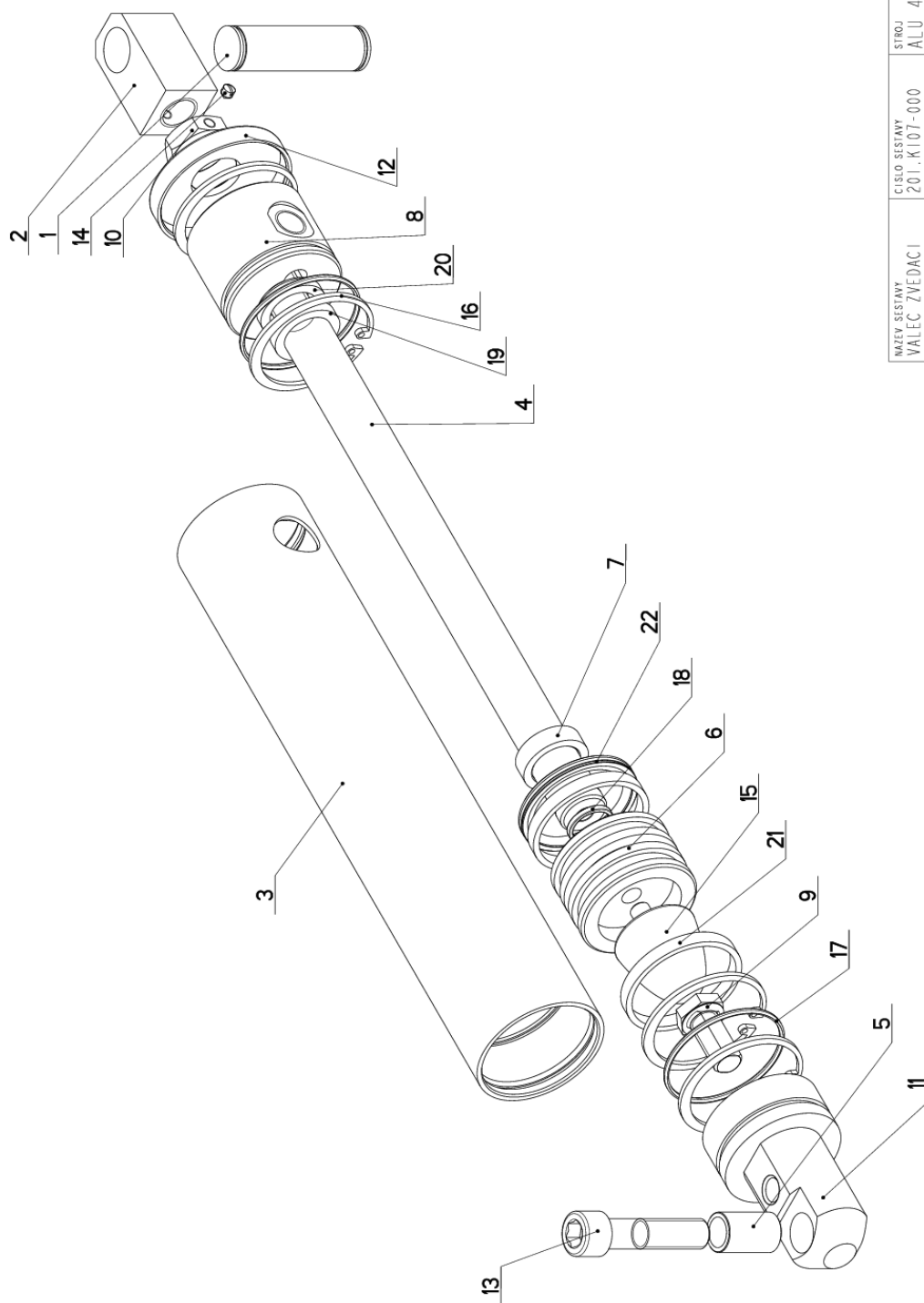

NAZEV SESTAVY VALEC ZVEDACI	CISLO SESTAVY 201.K107-000	STROJ ALU 400
		
Konstruoval: ZAJIC		
Datum: 30. 09. 2015		
Měřitko: 1:2		

6.27. Kusovník / Piece list / Stückliste - Válec zvedací / Lifting cylinder / Hebezyylinder

Císlo Sestavy 201. K107-000		Ver. 4		Název sestavy VALEC ZVEDACI / LIFTING CYLINDER / HEBEZYLINDER	
Poz.	Objednací číslo	Ver.	Název položky	Rozměr	Ks
1	30.0514-904	0	CEP / LUG / BOLZEN	d 18	1
2	30.0807-006	2	DRZAK / HOLDER / HALTER	TYC 25x25	1
3	30.K107-001	0	VALEC / ROLLER / ZYLINDER	TR 55/50H8	1
4	30.K107-002	0	PISTNICE / PISTON ROD / KOLBENSTANGE	d20	1
5	30.K107-003	2	POUZDRO / SLEEVE / BÜCHSE	d 18	1
6	30.K107-004	2	PIST / PISTON / KOLBEN	D 55	1
7	30.K107-005	0	DISTANC / DISTANCE / DISTANZ	TR 28x4	1
8	30.K107-008	4	VÍKO / COVER / DECKEL	d 55	1
9	30.K107-009 (2)	1	SROUB 6HRANNÝ / 6 SIDED BOLT / SECHSKANTSCHRAUBE	SROUB M12x25	1
10	30.K107-010 (4)	0	MATICE / NUT / MUTTER	MATICE M16	1
11	30.K107-011	2	VÍKO / COVER / DECKEL	d 50	1
12	31.2807-006 (3)	0	VÍKO / COVER / DECKEL		1
13	90.001.25.062	0	SROUB IMBUS / ALLEN HEAD BOLT / IMBUSSCHRAUBE	M12x50	1
14	90.003.20.001 (4)	0	SROUB STAVECI / ADJUSTMENT BOLT / STELLSCHRAUBE	SROUB M5x6	1
15	94.700.001 (2)	0	SILENTBLOK / SILENT BLOCK / SCHWINGUNGSDÄMPFER		1
16	95.801.018	0	KROUZEK POJIST.VNITR / OUTSIDE SAFETY RING / SICHERUNGSRING AUSSEN	POJISTINÝ KROUZEK 50	4
17	96.001.013	0	O-KROUZEK STATIC / STATIC O RING / O-RING STATISCH	45x2	2
18	96.002.007	0	KROUZEK O DYNAMICKÝ / DYNAMIC O RING / O-RING DYNAMISCH	16x2 NBR 70SH	1
19	96.041.002	0	TESNENÍ / SEALING / DICHTUNG	601-20x28x5	1
20	96.060.002	0	KROUZEK STIRACÍ / SCRAPER RING / ABSTREIFRING	KROUZEK STIRACÍ 20	1
21	96.084.001	0	KROUZEK VODICI / LEAD RING / FÜHRUNGSRING	GP8500500-T47	2
22	96.900.001	0	TESNENÍ KOMBINOVANÉ / COMBINATION SEALING / KOMBIDICHTUNG	PW4200500-Z20N	1

1. NOVA SOUCAST 30.K107-007. 28.1.2004 ZAJIC
2. ZRUS.SOUCAST 30.K107-006, 30.K107-007 A NAHR. 30.K107-009, 94.700.001, ZRUS. 30.4107-003 A NAHR. 30.K107-011. 31.5.2004 ZAJIC
3. PRIDANO VÍKO VALCE 31.2807-006. 023/ZM048 26.2.2008 SLEZACKOVA
4. ZRUS.MATICE M16(90.101.55.003) A NAHR. 30.K107-010, PRIDAN SROUB STAVECI M5x6(90.003.2D.001). 072/ZM097 14.4.2014 SLEZACKOVA

Císlo Sestavy/Number of assembly/Nummer der Baugruppe; Verze (Ver./Version/Version); Název sestavy/Assembly title/Name der Baugruppe; Pozice (Poz./Position/Position);
Objednací číslo/Purchase order number/Bestellnummer; Název položky/Volume title/Name der Position; Rozměr/Stock size/Abmessung

6.28. Upínání horní / Top clam / Spannvorrichtung oben

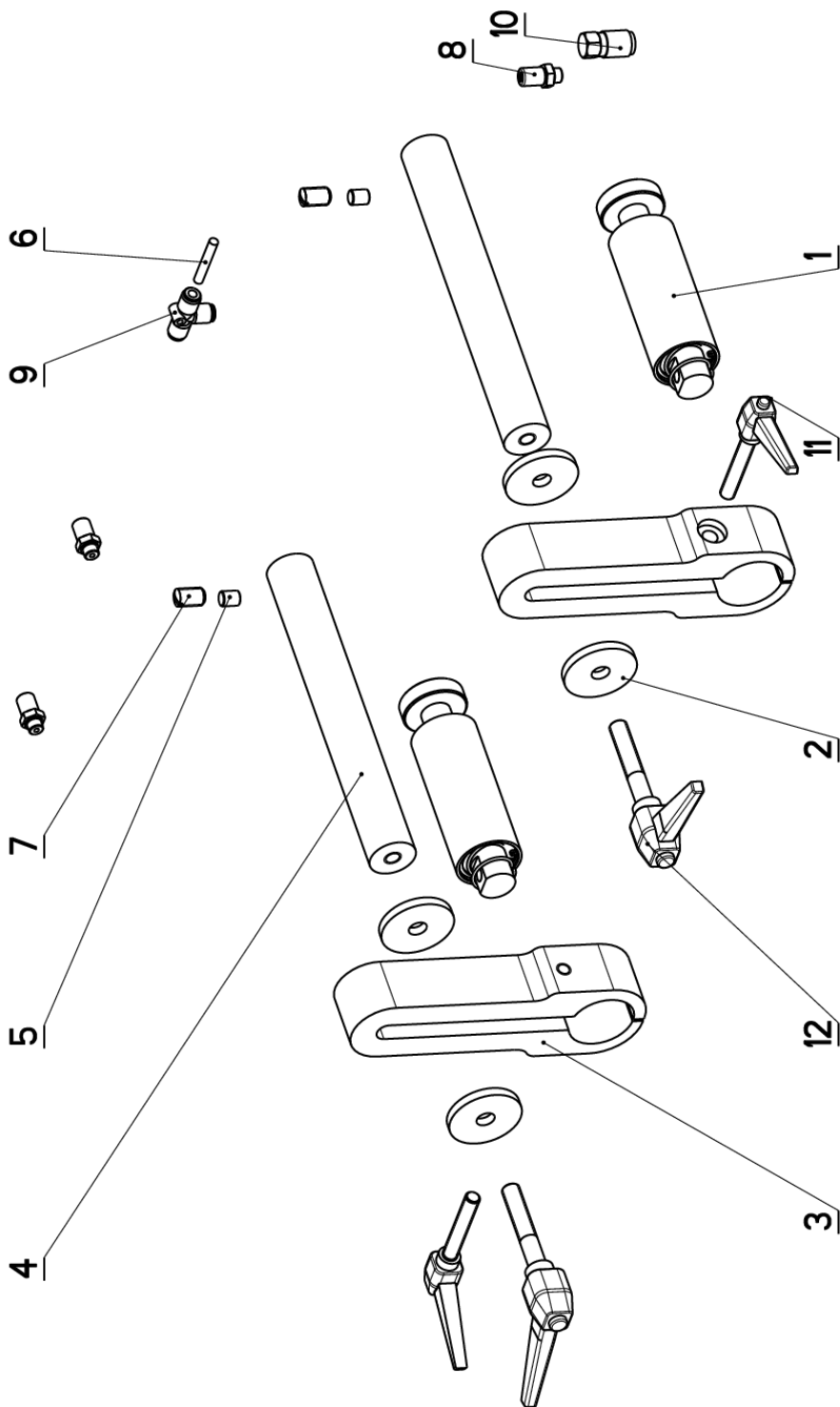

MAZEV SESTAVY UPÍNANÍ HORNÍ	CÍSLO SESTAVY 201.K114-000	STROJ ALU-400
	Konstruoval: ZAJIC	Datum: 08. 04.2011
	Meritko: 2:5	

6.29. Kusovník / Piece list / Stückliste -
Upínání horní / Top clam / Spannvorrichtung oben

Císlo sestavy 201.K114-000		Ver. 4		Název sestavy UPINANI HORNÍ / TOP CLAM/SPANNVORRICHTUNG OBEN	
Poz.	Objednací číslo	Ver.	Název položky	Rožmer	Ks
1	201.K107-200	0	VALEC UPINACÍ / FIXING CYLINDER / SPANNZYLINDER		2
2	30.0502-603	1	PODLOŽKA / WASHER / UNTERLEGSCHIBE	d50	4
3	30.K103-004	2	DRŽAK / HOLDER / HALTER	ODLITEK	2
4	30.K103-019	0	TYC / POLE / STANGE	d 32	2
5	30.K103-022	0	VALEČEK / CYLINDER / ROLLE	d 10	2
6	43.001.008	0	HADICE / HOSE / SCHLAUCH	PU6	1
7	90.002.20.018	0	SROUB STAVEČÍ / ADJUSTMENT BOLT / STELLSCHRAUBE	SROUB M12X20	2
8	93.005.001	0	SROUBENÍ PRÍME / DIRECT BOLTING / GERADE VERSCHRAUBUNG	G 1/8-6/4	3
9	93.011.002	0	PROPOJKA T / CONNECTION T / VERBINDUNGSSTÜCK T	6	1
10	93.023.001	0	SPOJKA / JOINT / KUPPLUNG	182-1/8"	1
11	94.008.006	0	PAKA UPINACÍ / ATTACHMENT LEVER / SPANNHEBEL	M10	2
12	94.008.012	0	PAKA UPINACÍ / ATTACHMENT LEVER / SPANNHEBEL	M12x70	2

Císlo sestavy/Number of assembly/Nummer der Baugruppe; Verze (Ver.)/Version/Version; Název sestavy/Assembly title/Name der Baugruppe; Pozice (Pos.)/Position/Position;
Objednací číslo/Purchase order number/Bestellnummer; Název položky/Volume title/Name der Position; Rožmer/Stock size/Abmessung

6.30. Válec upínací / Fyxing cylinder / Spannzyylinder

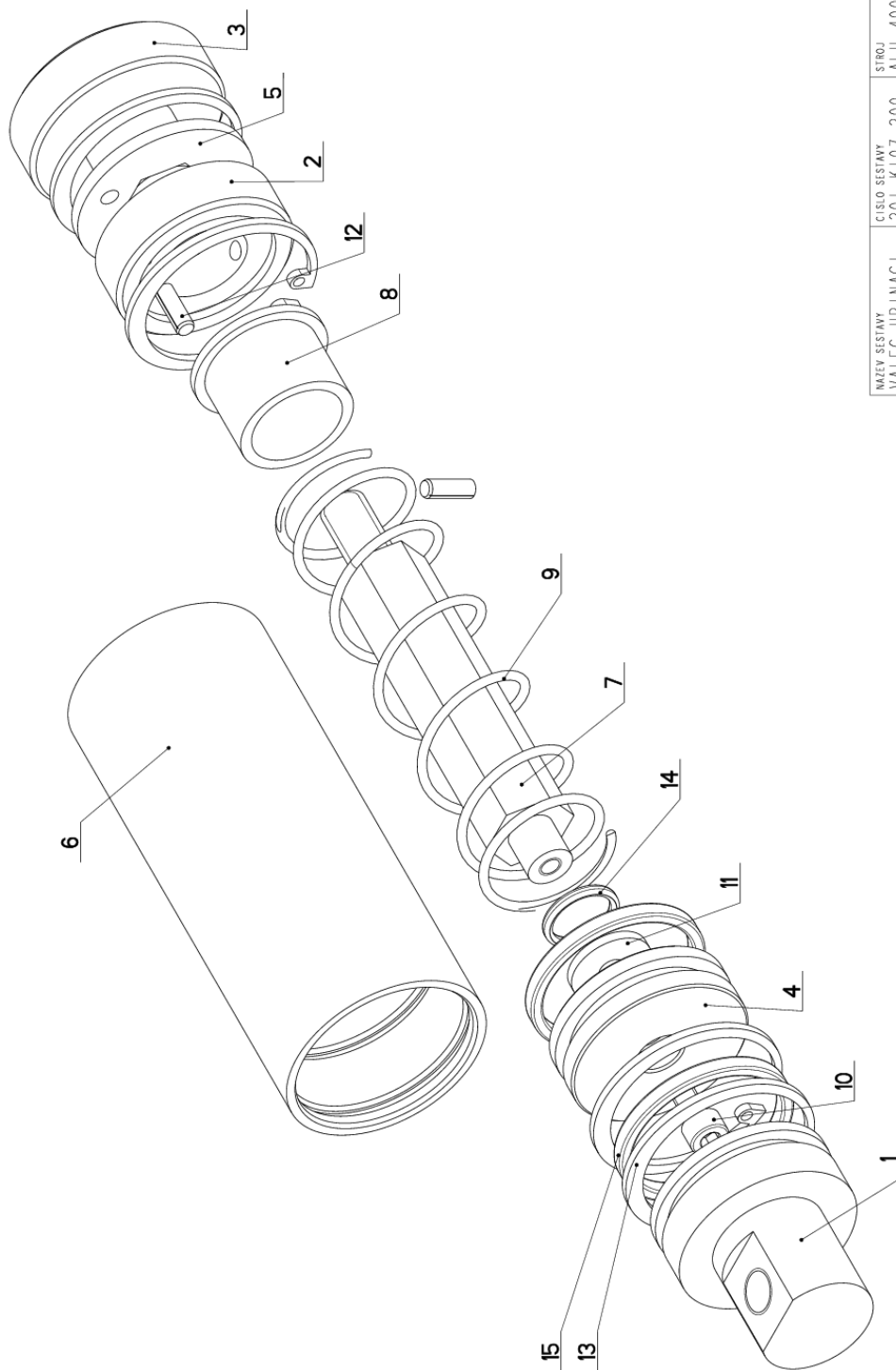

NAZEV SESTAVY VÁLEC UPÍNACÍ	CÍSLO SESTAVY 201-K107-200	STROJ ALU-400
		Konstruoval: ZAJIC
		Datum: 13. 04. 2015
		Meritko: 1:1

6.31. Kusovník / Piece list / Stückliste - Válec upínací / Fyxing cylinder / Spannzylinder

Císlo Sestavy 201.K107-200		Ver. 0		Název sestavy VALEC UPÍNAČI / FIXING CYLINDER / SPANNZYLINDER	
Poz.	Objednací číslo	Ver.	Název položky	Rožmer	Ks
1	30.K107-102	0	VÍKO / COVER / DECKEL	d 45	1
2	30.K107-103	1	VÍKO / COVER / DECKEL	d 45	1
3	30.K107-105	1	DORAZ / STOP PIECE / ANSCHLAG	d 50	1
4	30.K107-106	3	PIST / PISTON / KOLBEN	d 45	1
5	30.K107-111	2	KROUZEK VODÍČI / LEAD RING / FÜHRUNGSRING	d 40	1
6	30.K107-201	1	VALEC / ROLLER / ZYLINDER	TR 45/40H8	1
7	30.K107-204	1	PISTNICE / PISTON ROD / KOLBENSTANGE	6HR 17	1
8	30.K107-209	0	VEDENÍ / GUIDE / BACKENFÜHRUNG	d30	1
9	31.K107-107	0	PRUŽINA / SPRING / FEDER	2x30x105x15+2	1
10	90.001.25.008	0	SROUB IMBUS / ALLEN HEAD BOLT / IMBUSSCHRAUBE	M5X12	1
11	90.151.50.006	0	PODLOŽKA / WASHER / UNTERLEGSCHIBE	PODLOŽKA 5	1
12	90.303.02.013	0	KOLÍK PRUŽNY / PIN / BOLZEN	KOLÍK 4X12	2
13	95.801.005	0	SEGR DÍRA / INSIDE SAFETY RING / SICHERUNGSRING INNEN	POJISTNÝ KROUZEK 40	4
14	96.001.004	0	O-KROUZEK STATIK / STATIC O RING / O-RING STATISCH	10X2	1
15	96.002.017	0	KROUZEK O DYNAMICKY / DYNAMIC O RING / O-RING DYNAMISCH	34x3 NBR 70SH	2

Císlo Sestavy/Number of assembly/Nummer der Baugruppe; Verze (Ver./Version/Version; Název sestavy/Assembly title/Name der Baugruppe; Pozice (Pos./Position/Position;
Objednací číslo/Purchase order number/Bestellnummer; Název položky/Volume title/Name der Position; Rožmer/Stock size/Abmessung

6.32. Klíče / Key / Schlüssel

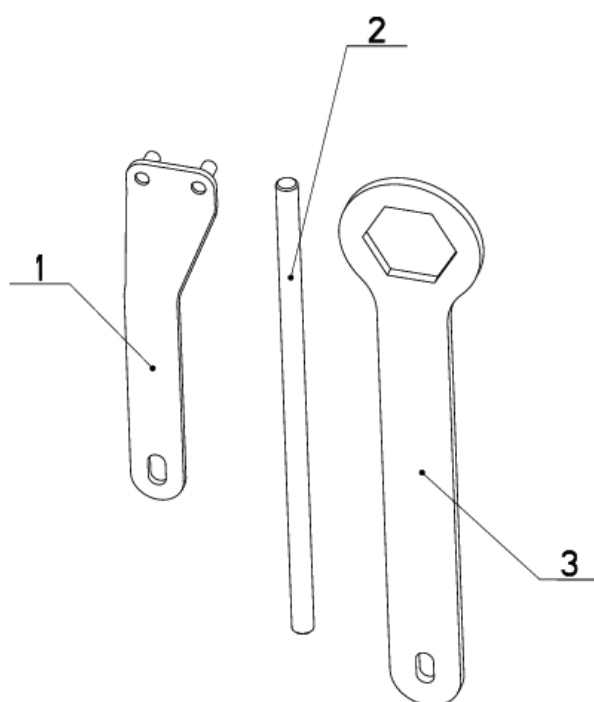

NAZEV SESTAVY KLIC	CISLO SESTAVY 201.K114-100	STROJ AL400
	Konstruoval:	
	Datum:	04. 05.2018
	Meritko:	33:100

6.33. Kusovník / Piece list / Stückliste - Klíče / Key / Schlüssel

Císlo sestavy 201.K114-100		Ver. 0		Název sestavy KLIC/KEY/SCHLÜSSEL	
Pos.	Objednávací číslo	Ver.	Název položky	Rožmer	Ks
1	30.K114-101	0	KLIC / KEY / SCHLÜSSEL		1
2	30.K114-102	0	TYC / POLE / STANGE	d 12	1
3	30.K114-104	0	KLIC / KEY / SCHLÜSSEL	P 4x60	1

Císlo Sestavy/Number of assembly/Nummer der Baugruppe; Verze (Ver./Version/Version; Název sestavy/Assembly title/Name der Baugruppe; Pozice (Pos./Position/Position;
Objednávací číslo/Purchase order number/Bestellnummer; Název položky/Volume title/Name der Position; Rožmer/Stock size/Abmessung

6.34. Pneumatika / Pneumatics / Pneumatik

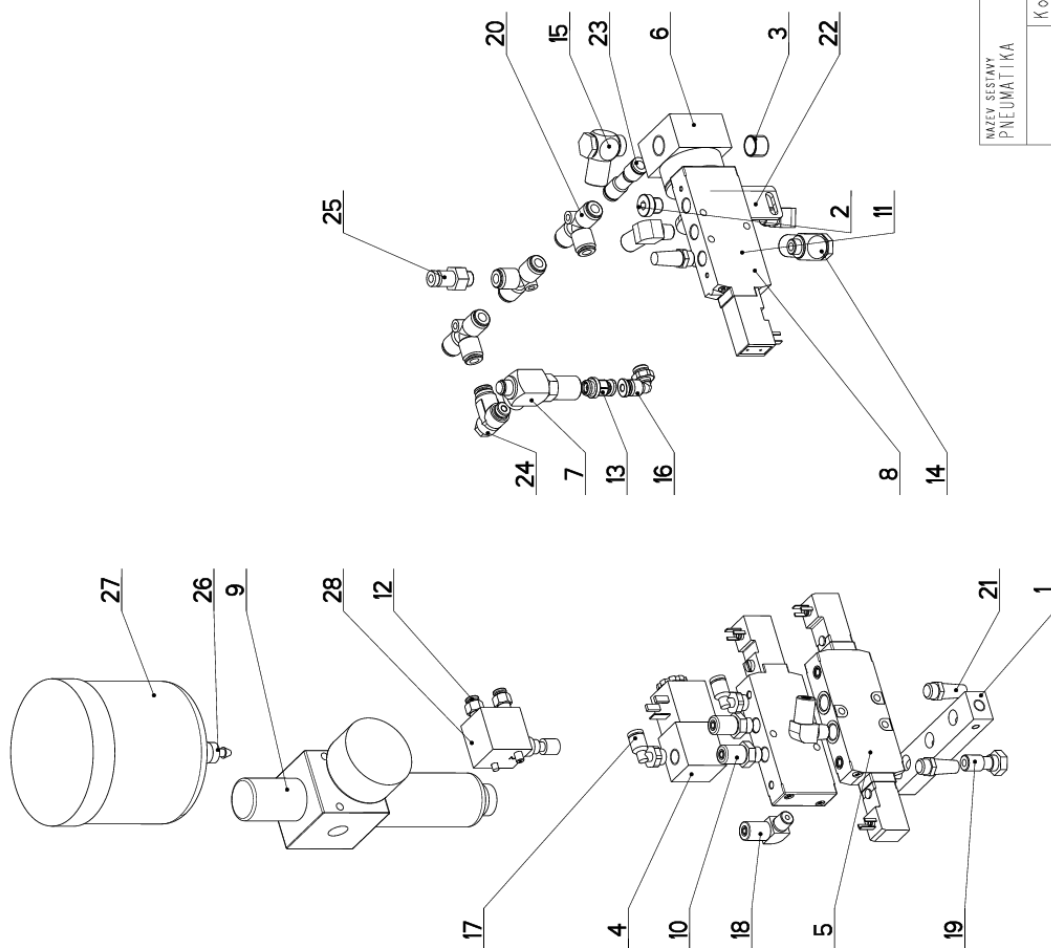

NAZEV SESTAVY PNEUMATIKA	CISLO SESTAVY 201.K116-000	STROJ ALL400/500
Konstruoval:		
Datum: 11. 05.2017		
Meritko: 2:5		

6.35. Kusovník / Piece list / Stückliste - Pneumatika / Pneumatics / Pneumatik

Cílo Sestavy 201.K116-000		Ver. 6		Název sestavy PNEUMATIKA/TYRE/PNEUMATIK	
Por.	Objednací číslo	Ver.	Název položky	Rozebr	ks
1	30.0915.101	1	KOSTKA ROZVADĚCÍ / DISTRIBUTION CUBE / VERTEILUNGSWÜRFEL	HR ZD415	1
2	92.019.023	0	ZATKA / PLUG / STOPFEN	G1/4" VNITŘNÍ IMBUS	1
3	92.019.024	0	ZATKA / PLUG / STOPFEN	1/4"	1
4	93.001.008 (1)	0	VENTIL / VALVE / VENTIL	VENTIL MAGNETICKÝ	1
5	93.001.012 (6)	0	VENTIL / VALVE / VENTIL	082006001	1
6	93.002.014	0	REGULATOR / REGULATOR / REGLER		1
7	93.002.038 (5)	0	VENTIL / VALVE / VENTIL	G1/8	1
8	93.002.044 (2)	0	VENTIL / VALVE / VENTIL		2
9	93.003.001	0	VENTIL REDUKČNÍ / REDUCTION VALVE / DRUCKMINDERUNGSVENTIL		1
10	93.005.001	0	ŠROUBENÍ PRŮMĚ / DIRECT BOLTING / GERADE VERSCHRAUBUNG	G 1/8-6/4	2
11	93.005.005	0	MATICE / NUT / MUTTER		1
12	93.006.007	0	ŠROUBENÍ PRŮMĚ / /	M5/4	2
13	93.006.019 (5)	0	ŠROUBENÍ PRŮMĚ / DIRECT BOLTING / GERADE VERSCHRAUBUNG	50070	1
14	93.007.002	0	ŠROUBENÍ ÚHLOVĚ / ANGLE BOLTING / WINKELVERSCHRAUBUNG	G1/8"-8/6	1
15	93.007.004	0	ŠROUBENÍ ÚHLOVĚ / ANGLE BOLTING / WINKELVERSCHRAUBUNG	G1/8-8/6	1
16	93.007.005 (5)	0	ŠROUBENÍ ÚHLOVĚ / ANGLE BOLTING / WINKELVERSCHRAUBUNG	G 1/8"-4	1
17	93.007.005	0	ŠROUBENÍ ÚHLOVĚ / ANGLE BOLTING / WINKELVERSCHRAUBUNG	1/8" x 4	2
18	93.008.001	0	ŠROUBENÍ ÚHLOVĚ / ANGLE BOLTING / WINKELVERSCHRAUBUNG	R1/8"-6/4	4
19	93.010.001	0	ŠROUB / BOLT / SCHRAUBE	DUTY	1
20	93.011.002	0	PROPOJKA T / CONNECTION T / VERBINDUNGSSTÜCK T	6	3
21	93.014.003	0	TLUMIČ / DAMPER / DÄMPFER	G 1/8	3
22	93.019.012	0	DRŽÁK / HOLDER / HALTER	DRŽÁK BOSCH	1
23	93.021.009	0	VENTIL ŠRTICÍ / CHOKE VALVE / DROSSELVENTIL		1
24	93.021.045 (5)	0	VENTIL ŠRTICÍ / CHOKE VALVE / DROSSELVENTIL	1/8" 6/4	1
25	93.023.002	0	SPOJKA / JOINT / KÖPPLUNG	RICHLOPOLJKA	1
26	93.024.001	0	VENTIL / VALVE / VENTIL	ZPEVNĚNÝ	1
27	94.404.001	0	NAŘZ / CONTAINER / BEHÄLTER	MIKRONIZÉR	1
28	99.150.002	0	MIKRONIZÉR / MICRONIZER / MICRONIZER		1

1. ZRUSEN VENTIL ASCO 93.001.001 A NAHR. VENTILEM BOSCH 93.001.008 . 055/ZMI92 21.6.2010 SLEZACKOVA

2. ZRUSEN VENTIL 93.002.003 A NAHR.93.002.044. 062/ZM074 17.3.2015 SLEZACKOVA

5. ZRUS. VENTIL 93.021.002 A NAHR. VENTIL 93.002.038 A 93.021.045, ZRUS. SROUBENÍ 93.006.007 A NAHR. SROUBENÍ 93.006.019 A 93.007.005. 332/ZM052 14.2.2017 SLEZACKOVA

6. ZRUS. VENTIL 93.002.001 A NAHR. VENTILEM 93.001.012, 113/ZM174, 11.5.2017, KUDELA

Cílo Sestavy/Number of assembly/Nummer der Baugruppe; Verze (Ver./Version/Version; Název sestavy/Assembly title/Name der Baugruppe; Pozice (Pos./Position/Position;
Objednací číslo/Purchase order number/Bestellnummer; Název položky/Volume title/Name der Position; Rozměr/Stock size/Abmessung

7. **Výkresy sestav pro objednání náhradních dílů – volitelné příslušenství/ Zeichnungen für Bestellung der Ersatzteile – optionale Zubehör/ Drawing assemblies for spare parts order – optional accessories**

- Při objednávání náhradních dílů vždy uvádějte: typ stroje (např. AL 400) , výrobní číslo (např. 125) a rok výroby (např. 1999).
- In die Bestellung der Ersatzteile führen Sie immer an: Maschinentyp (z. B. AL 400), Serien Nr. (z. B. 125) und Baujahr (z. B. 1999).
- For spare parts order, you must always to allege: type of machine (for example AL 400), serial number (for example 125, see cover page) and year of construction (for example 1999).

7.1. Odměrován/ Measuring/ Gehrungsmessung (optional)

Císlo Sestavy 201. K114-360		Ver. 1		Název sestavy ODMĚROVÁNÍ / MEASURING / GEHRUNGSMESSUNG	
Poz.	Objednací číslo	Ver.	Název položky	Rozměr	Ks
1	30.K114-362	6	STUL / TABLE / TISCH	ODLITEK	1
2	30.K114-363	0	KOSTKA / CUBE / WÜRFEL	HR 30x25	1
3	30.K114-364	1	STERAC / WIPER / ABSTREIFER	BA18	2
4	30.K114-369	0	KRYT / COVER / ABDECKUNG	PI,5x18	1
5	30.Y414-038	0	DRŽAK / HOLDER / HALTER	P 4x120	1
6	30.Y414-039	1	KRABICE ELEKTRO / ELECTRO BOX / ELEKTRODOSE	100x100x80	1
7	90.001.25.036	0	SROUB IMBUS / ALLEN HEAD BOLT / IMBUSSCHRAUBE	M8x40	2
8	91.070.013	0	VYVODKA / BUSHING / TÜLLE	M25x1,5	1
9	91.270.016	0	JEDNOTKA ODMĚROVÁNÍ / MEASURING UNIT / MESSEINHEIT	I Z16E-000-1-01, 0-0	1
10	91.271.005	0	PASKA MAGNETICKÁ / MAGNETIC TAPE / MAGNETBAND	MB 20.25	1
11	96.081.003	0	KROUZEK TESNICÍ / SEAL RING / DICHTUNGSRING	PG 16 7x20,4x7,5	1

DIGITÁLNÍ ODMĚROVÁNÍ UHLU PRO ALU 400
STUL K114-362 NAHRAZUJE STANDARTNÍ STUL K103-002

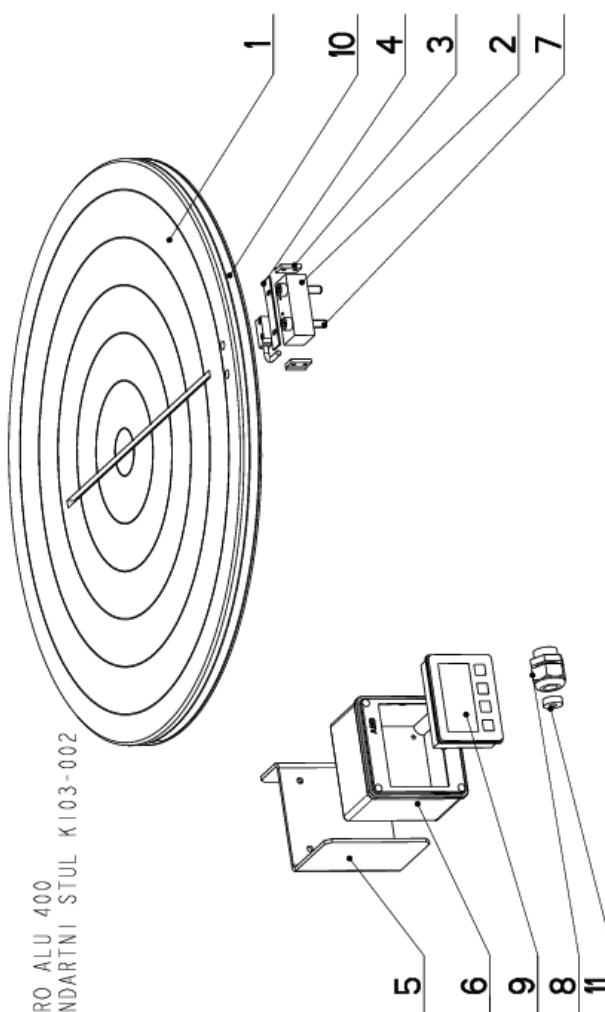

Císlo Sestavy/Number of assembly/Nummer der Baugruppe; Verze (Ver./Version/Version; Název sestavy/Assembly title/Name der Baugruppe; Pozice (Pos./Position/Position;
Objednací číslo/Purchase order number/Bestellnummer; Název položky/Volume title/Name der Position; Rozměr/Stock size/Abmessung

7.2. Kryty / Covers / Abdeckungen

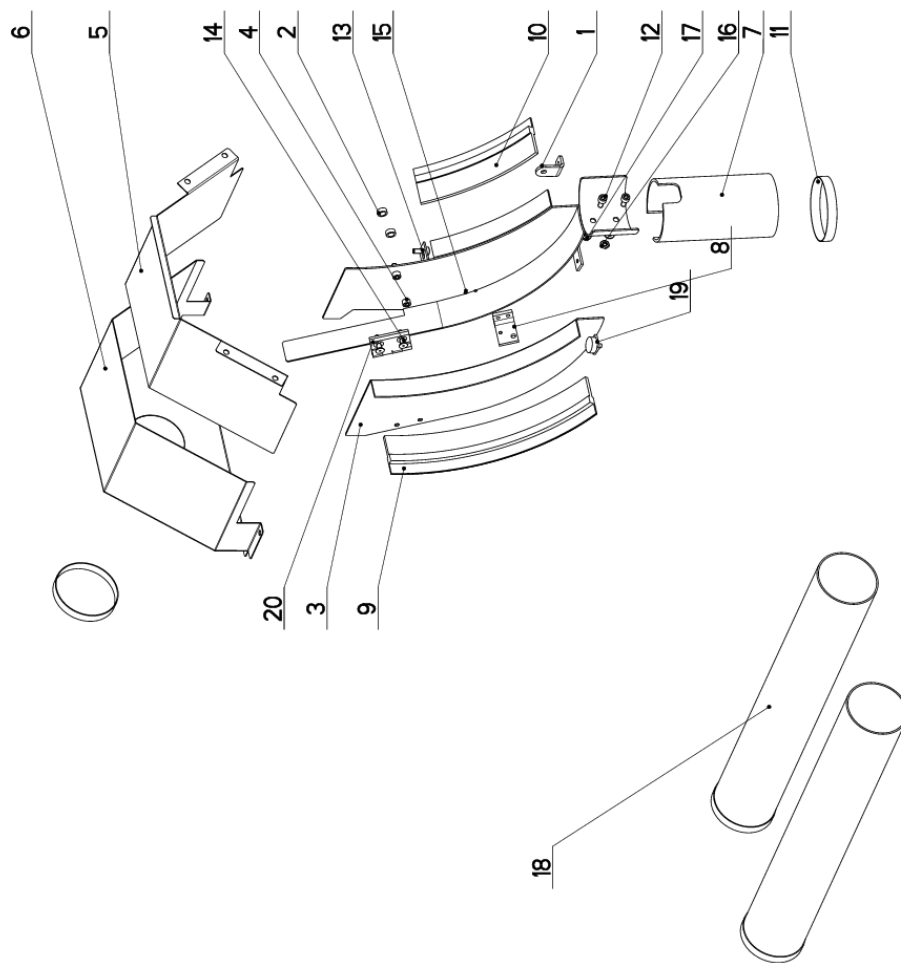

NA ODSAVANI AL-KO

NAZEV SESTAVY KRYTY	CISLO SESTAVY 201.K115-400	STROJ AL400
		
Konstruoval: SOCHOR		
Datum: 14. 09. 2018		
Meritko: 1:5		

7.3. Kusovník / Piece list / Stückliste - Kryty / Covers / Abdeckungen

Císlo Sestavy 201. K115-400		Ver. 0		Název sestavy KRYTY/COVERS/ABDECKUNGEN	
Poz.	Objednací číslo	Ver.	Název položky	Rozměr	Ks
1	30.6114-023	0	DRŽAK / HOLDER / HALTER	P 3x20	1
2	30.K115-205	0	DISTANC / DISTANCE / DISTANZ	TR 12x2	2
3	30.K115-302	0	DVERE / DOOR / TUR		1
4	30.K115-401	0	KRYT / COVER / ABDECKUNG		1
5	30.K120-082	1	PLECH / PLATE / BLECH	P 1x168	1
6	30.K120-481	0	KRYT / COVER / ABDECKUNG		1
7	30.K415-408	0	TRUBKA / TUBE / ROHR	80	1
8	30.K920-062	0	DRŽAK MIKRONIZERU / HOLDER / HALTER	P 4x25	1
9	49.250.004	0	KARTAC / BRUSH / BÜRSTE	FBL6000-K5	1
10	49.250.004	0	KARTAC / BRUSH / BÜRSTE	FBL6000-K5	1
11	61.500.007	0	UCHYTKA / CLIP / HALTER	TORRO 70-90	4
12	90.001.25.016	0	SROUB IMBUS / ALLEN HEAD BOLT / IMBUSSCHRAUBE	M6x12	2
13	90.001.25.092	0	SROUB IMBUS / ALLEN HEAD BOLT / IMBUSSCHRAUBE	M6x14	3
14	90.011.27.004	0	ZAPUSTNÝ IMBUS / COUNTERSINK BOLT / SENKSCHRAUBE	SROUB M6x10	4
15	90.013.27.001	0	SROUB / BOLT / SCHRAUBE	M4x8	2
16	90.101.55.008	0	MATICE / NUT / MUTTER	MATICE M6	2
17	90.150.90.004	0	PODLOŽKA / WASHER / UNTERLEGSCHIEBE	PODLOŽKA 6,4	2
18	93.026.011	0	HADICE / HOSE / SCHLAUCH	DN 80 PU-M	2
19	94.007.001	0	SROUB / BOLT / SCHRAUBE	M5x10	1
20	99.100.010	0	PANT / HINGE / TÜRBAND		1

Císlo Sestavy/Number of assembly/Nummer der Baugruppe; Verze (Ver./Version/Version; Název sestavy/Assembly title/Name der Baugruppe; Pozice (Pos./Position/Position;
Objednací číslo/Purchase order number/Bestellnummer; Název položky/Volume title/Name der Position; Rozměr/Stock size/Abmessung